

ZICO®

3030PM11

QUIC-RELEASE® CYLINDER LIFT
MODEL QR-CL
PARTS SHEET AND USER MANUAL

Why risk back strain or injured feet when exchanging medical oxygen cylinders? The ZICO® Cylinder Lift System raises and lowers "M" through "J" cylinders. Easily remove the empty cylinder and replace it with a full one.

The unit operates off of a supplied 12v battery. A charger is provided with the unit.

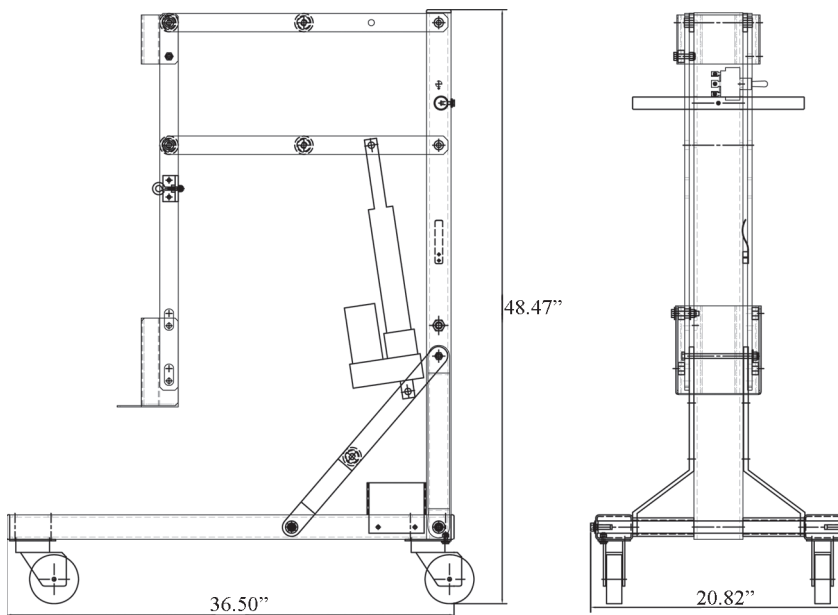

MODEL	DESCRIPTION	WT./@ IN LBS.
QR-CL	Complete system	130.0



ITEM NO.	PART NO.	DESCRIPTION	QTY.
1A	3030-250-101	Leg, Left	1
1B	3030-250-102	Leg, Right	1
2	3030-250-103	Main Upright	1
3	3030-250-105	Tie Rod	1
4	3030-250-107	Forward Brace	2
5	3030-250-163	Threaded Spacer	2
6	3030-250-111	Lifting Arms	4
7	3098-105-113	Actuator	1
8	3030-250-113	Handle	1
9	3030-250-115	Cylinder Support Bar	2
10	3030-250-117	Footplate	1
11	3030-250-119	Lower Cyl Support	1
12	3030-250-121	Upper Cyl Support	1
13	3030-250-123	Forward Swivel Casters	2
14	3030-250-125	Rear Swivel Locking Casters W/Brakes	2
15	3030-250-157	Spacer, Actuator, Short	2
16	3030-250-129	Spacer, 1.5 OD x 1.125 ID x 5 LG, AL	2
17	3030-250-131	Spacer, 1.5 OD x 1.125 ID x 4 LG, AL	3
18	3030-250-159	Spacer, Actuator, Long	2
19	3030-250-135	Spacer, 1.0 OD, x .391 ID x .520 LG, Std.	8
20	3030-250-137	Bushing, Pivot, .744 OD x 385 ID x .390 LG.	12
21	9118-105088	Screw, 1/2ø x 5.5, HH, GR. 8	2
22	9015-103728	Screw, 3/8ø-16 x 1 3/4, HH	4
23	9015-103764	Screw, 3/8-16 x 4, HH	2
24	9015-103788	Screw, 3/8-16 x 5 1/2, HH	5
25	9015-103736	Screw, 3/8-16 2 1/2, HH	2
26	9015-103732	Screw, 3/8-16 x 2, HH	4
27	9013-133700	Nut, 3/8-16 Nylock	15
28	9014-113700	Flatwasher, 3/8ø NOM.	24
29	9014-203700	Lockwasher, 3/8ø	6
30	1045-320-171	Spacer, Belt Holder Spring	2
31	3025-000-110	Aligner, Plastic Tube	3
32	9010-102516	Screw, 1/4-20 x 1 HH	21
33	9014-112500	Flatwasher, 1/4ø	20
34	9015-172500	Nut, 1/4-20 Nylon Lock	20
35	9013-173100	Nut, 5/16-18 Nylon Lock	1
36	9014-202500	Lockwasher, 1/4ø Split	1
37	3094-000-111	Spring, Flat	1
38	3097-105-145	Boot, Switch	1
39	3097-500-172	Strain Relief	1
40	3097-105-146	Washer, Switch Anti-Rot.	1
41	3097-105-144	Switch, Toggle, DPDT, MOM	1
42	9015-103720	Screw, 3/8-16 x 1 1/4 HH, GR. 5	2
43	3030-250-155	Cord Assembly, Electrical	1
44	3030-250-161	Battery Holder	2
45	3030-250-145	Battery 12V	1
46	3030-250-145	Screw, 1/4-20 x 3 3/4 LG., HH	2
47	3030-250-143	Buckle	1
48	3030-250-147	Mounting Plate, Belt Buckle	1
49	3030-250-149	Spacer, Buckle Mtg. Plate	1
50	9010-221612	Screw, 8-32 x 3/4 Pan Hd.	4
51	9013-171600	Nut, 8-32 Hex, Nylock	4
52	3030-250-151	Strap Assembly	1
53	9010-582524	Eyebolt, 5/16-18 x 2 ZPS	1
54	3030-250-153	Eyebolt Bracket	1
55	3030-250-139	End Cap, Plastic, 2 x 3	4

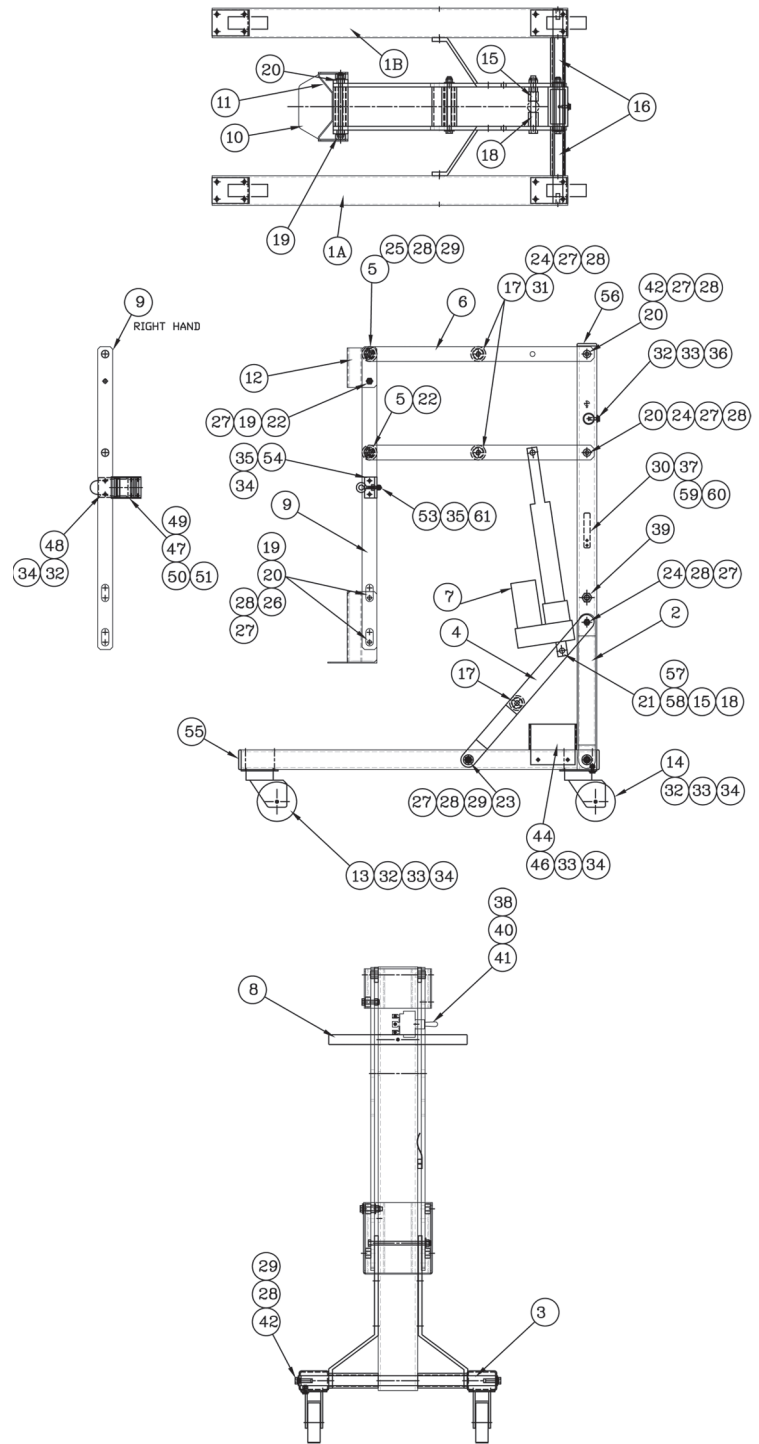

ITEM NO.	PART NO.	DESCRIPTION	QTY.
56	3030-250-141	End Cap, Plastic, 2 x 4	1
57	9012-105000	Nut, 1/2-13, Jam	2
58	9013-175000	Nut, 1/2-13, Hex Nylock	2
59	9010-222012	Screw, 10-32 x 3/4 Pan Hd.	2
60	9014-201900	Lockwasher, # 10 Split	2
61	9014-113100	Flatwasher, 5/16øNOM	1
62	3030-250-167	Model Number Tag	1
63	3030-250-179	Edge Protector, 4" Lg.	2
64	3030-250-181	Edge Protector, 2.5" Lg.	2

Assembly Instructions

1. Lay the QR-CL on a flat surface such as a table or the floor. The shipping box can be used as padding to protect the QR-CL for assembly. The unit should be laying on the main upright. The wheels should be facing up.

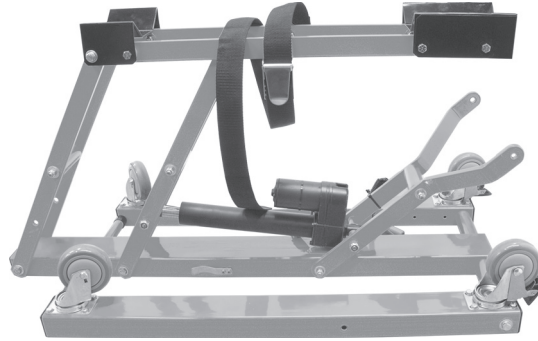

2. Assemble the horizontal legs by raising the right hand and left hand legs separately. Attaching them to the forward brace, using (1) 3/8-16" x 4" hex head bolt, (1) 3/8-16" self locking nut, and (1) 3/8" flat washer on each side. (Note: Keep the hardware loose at this time.)



3. Make sure the horizontal legs are perpendicular to the main upright. Tighten the 3/8-16" bolts on the forward bracer and the horizontal legs. It is suggested the bolts be torqued to 18 FLBS.
4. Stand the QR-CL up so that it is now sitting on the wheels.

5. Install the left and right battery brackets using (2) 1/4-20" x 3-3/4" long screw, (2) 1/4-20" self locking nut, (2) 1/4" flat washer for each side.

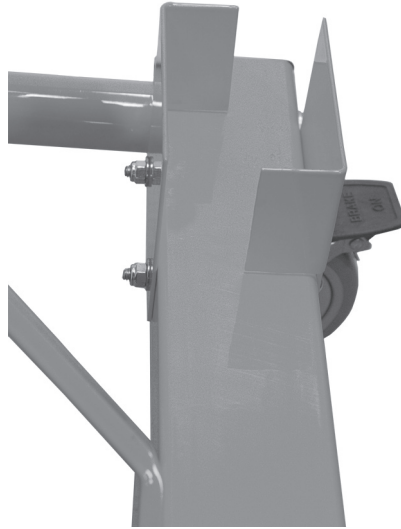

6. Install the battery into the battery holder. Attach the red wire to the positive terminal and the black wire to the negative terminal.

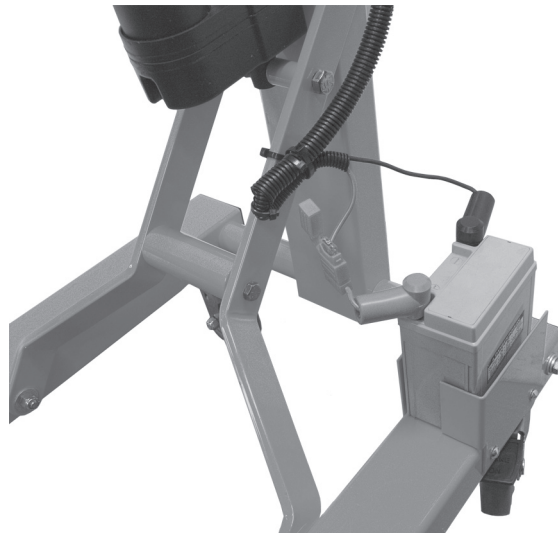

The QR-CL is now ready to operate. Read the rest of the manual before use.

The battery must be charged 5-8 hours before to first use. Do not exceed more than a 24 hour charge.

Removing the empty cylinder

1. Remove the oxygen line and install the safety cap. Remove all straps holding the cylinder except for the upper one.
2. Remove the strap from the QR-CL and then feed it around the cylinder.
3. Roll the QR-CL as close as possible without making contact with the truck. Raise the footplate to clear the truck deck. First attach the QR-CL strap to the eye hook on the QR-CL. Feed the strap end into the buckle and pull the strap to bring the QR-CL to the bottle. Make sure the footplate is under the cylinder bottom. Tighten the strap and secure the buckle latch.
4. Remove the final strap holding the cylinder in the vehicle. Raise the cylinder off of the deck and slowly roll the QR-CL back until the cylinder is clear of the vehicle's deck.
5. Lower the cylinder so that the bottom is just below the horizontal leg. It is now ready to transport.

Loading a cylinder on the cart

1. Move the QR-CL up to the edge of the cylinder. Angle the cylinder slightly and slide the footplate under the bottle.
2. Secure the brakes on the QR-CL, and then wrap the strap around the cylinder. Feed the strap into the buckle, then tighten the strap and secure the buckle latch.
3. Raise the cylinder no higher than the horizontal legs while transporting the bottle. Release brakes and move the cylinder.

Placing a full cylinder in the vehicle

1. Roll the QR-CL as close as possible to the vehicle without making contact.
2. Raise the cylinder up to clear the vehicle deck.
3. Roll the QR-CL forward until the cylinder is in the containment bracket. Apply the brakes on the cart and lower the cylinder down to the deck.
4. Secure the cylinder into the bracket on the vehicle.
5. Unlatch the strap buckle on the QR-CL and release the brakes. Slowly roll the lift backwards. The strap will slide out behind the cylinder. Remove the safety cap on the cylinder and reconnect the line to it.



Ziamatic Corp.

10 West College Avenue, P.O. Box 337, Yardley, PA 19067-0587 • (215) 493-3618 • FAX: (215) 493-1401

www.ziamatic.com

TOLL FREE: 800-711-3473

*ZICO is a registered trademark for fire, safety and marine products made by Ziamatic Corp.

Copyright Ziamatic Corp. 4-09