

QUIC-MOUNT® EXTRICATION TOOL HOLDER FOR BATTERY-POWERED CUTTER
MODEL QM-ET-MVE
PARTS AND INSTRUCTION MANUAL

3095PM11

Rev. 1-10-19

The QM-ET-MVE holds self-contained/battery-powered cutter extrication tools securely upright in the compartment.

Fully adjustable, the various components slide to fit your individual tool for a most secure fit. Tilt angle is also adjustable.

Raised cradle arm component grips the tool handle and supports the weight of the battery end.

Made with heavy-duty, lightweight aluminum.

Mounts to virtually any flat surface.

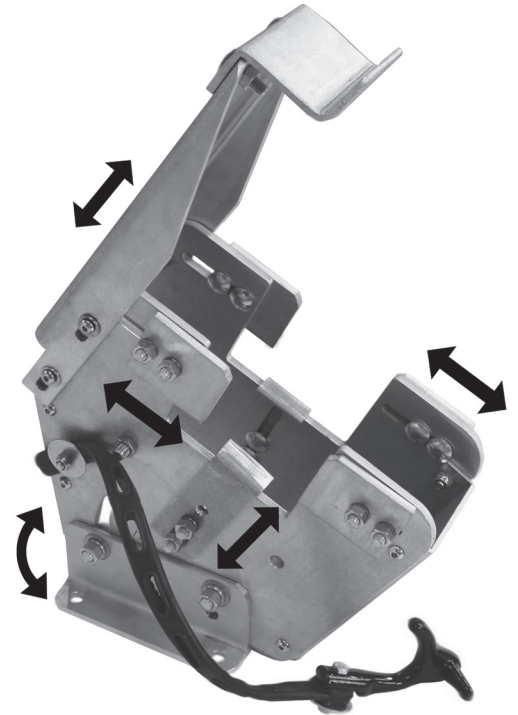

MODEL	DESCRIPTION	WT./@ IN LBS.
QM-ET-MVE	Extrication Tool Holder for Battery-Powered Cutter	8.6

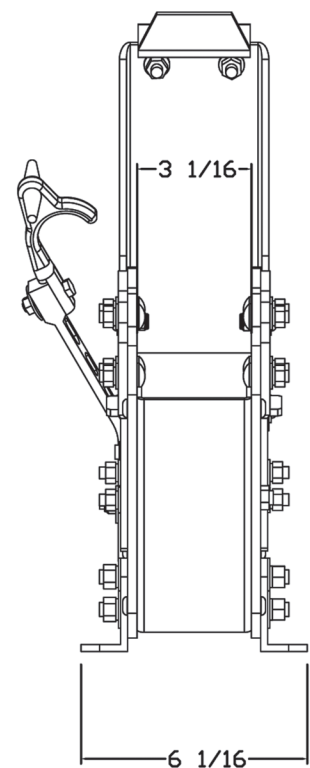
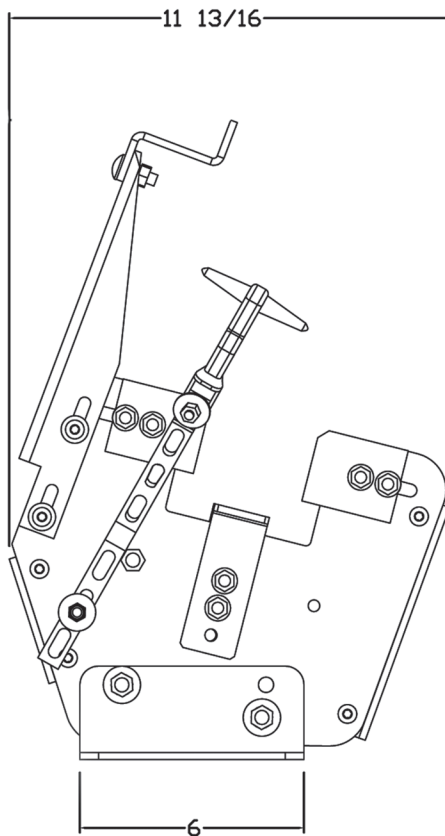

Parts Diagrams - QM-ET-MVE

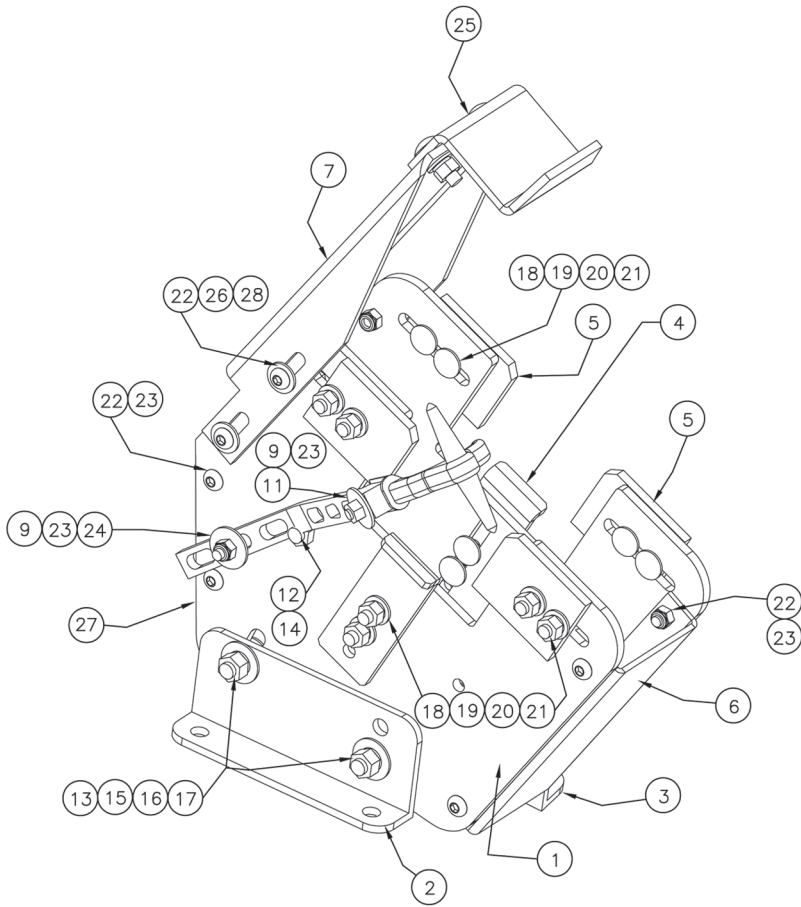

Exploded View

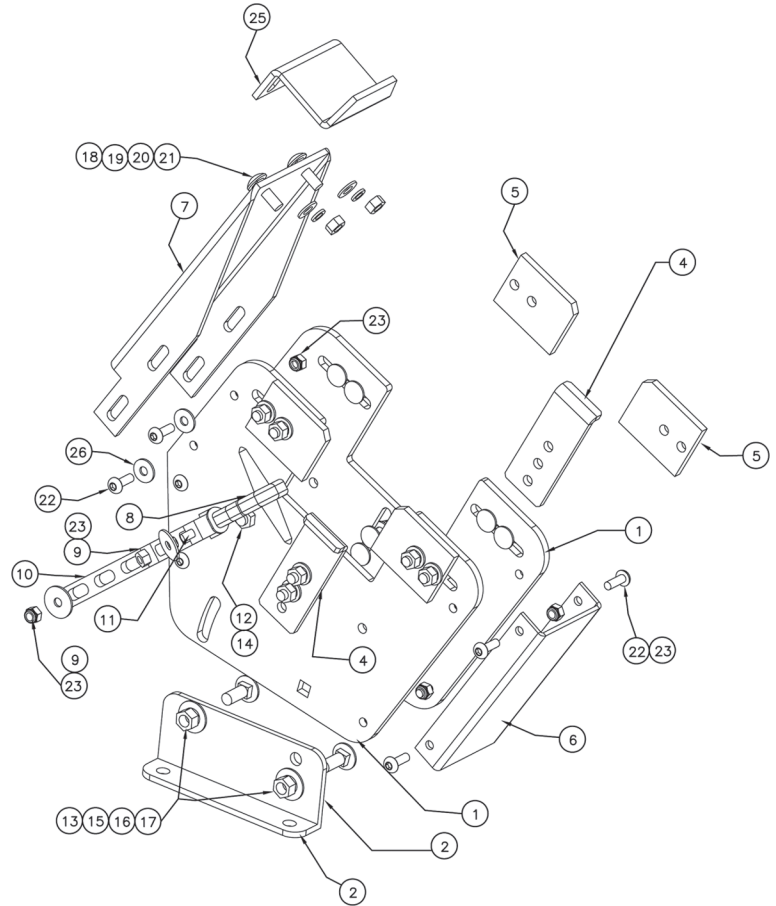

Isometric View

Parts Breakdown - QM-ET-MVE

ITEM #	PART #	DESCRIPTION	QTY.
1	3095-242-101	VERTICAL BOX PLATE SHORT	2
2	3095-235-103	VERTICAL BOX MOUNTING ANGLE LEFT	1
3	3095-235-105	VERTICAL BOX MOUNTING ANGLE RIGHT	1
4	3095-235-107	VERTICAL BOX CENTER ADJUSTER W/TAB	2
5	3095-235-109	VERTICAL BOX SIDE ADJUSTER	4
6	3095-235-111	VERTICAL BOX LONG CHANNEL	1
7	3095-242-103	VERTICAL BOX SHORT, EXTENTION	1
8	3095-215-109	STRAP HANDLE	1
9	9014-162500	WASHER, 1/4" WIDE	2
10	3095-215-107	EPDM RUBBER STRAP	1
11	9015-102520	1/4"-20 X 1-1/4" HEX HD BOLT ZPS	1
12	9015-633720	3/8"-16 X 1.25" CARRIAGE BOLT, G5-5 ZPS	2
13	9015-633716	3/8"-16 X 1" CARRIAGE BOLT, G5-5 ZPS	4
14	9012-203700	3/8"-16 JAM NUT ZPS	4
15	9014-113700	3/8" FLAT WASHER ZPS	4
16	9014-203700	3/8" SPLIT LOCK WASHER ZPS	4
17	9012-103700	3/8"-16 NUT, ZPS	4
18	9015-633116	5/16"-18 X 1" CARRIAGE BOLT, G5-5 ZPS	14
19	9014-103100	5/16" FLAT WASHER (5/16 X 9/16 X 1/16)	14
20	9014-203100	5/16" SPLIT LOCK WASHER, ZPS	14
21	9012-103100	5/16"-18 NUT, ZPS	14
22	9010-502512	1/4"-20 X 3/4" BUTTON CAP SCREW, ZPS	12
23	9015-172500	1/4"-20 NYLOCK NUT, ZPS GR5	10
24	9015-102520	1/4"-20 X 1-1/4" HEX HEAD BOLT, ZPS	1
25	3095-242-105	VERTICAL BOX SHORT, HANGER	1
26	9014-182500	1/4" WASHER, GRADE 8	4
27	3095-235-113	VERTICAL BOX SHORT CHANNEL	1
28	9013-172500	1/4"-20 LOCKNUT, ZPS	4

Adjustment Instructions

Note: Part numbers in parentheses. Refer to page 3.

Set-up: Adjustment is most easily accomplished with the QM-ET-MVE out of the compartment and in full upright position (as shipped).

1. Place tool you wish to mount completely into the holder. For wider tools, position the Vertical Box Long Channels (6) and Vertical Box Short Channel (7) against the inner sides of the Vertical Box Plates (1). Set Center Adjusters (4) to achieve max engagement with tool while keeping weight off of vinyl hand guard. If you adjusted the Channels for a wider tool, you may need to rotate the Center Adjuster (4) tabs to the inside to achieve proper engagement.
2. Set Side Adjusters (5) to center the tool with a minimum of side play at frame yoke.
3. Set Blade Offset stop bolts (12) to square the tool in box.
4. Set Extension Arm (7) so that tool handle rests firmly in Hanger Cradle (25).
5. Adjust tilt angle at mounting flanges (13) as desired.
6. Adjust Strap Handle (8) and Rubber Strap (10) to secure tool.

Mounting Instructions

Mount at four points using 3/8" hardware (not included).



Ziamatic Corp.

10 West College Avenue, P.O. Box 337, Yardley, PA 19067-0587 • (215) 493-3618 • FAX: (215) 493-1401

www.ziamatic.com

TOLL FREE: 800-711-3473

*ZICO is a registered trademark for fire, safety and marine products made by Ziamatic Corp.

Copyright Ziamatic Corp. 1-19