

QUIC-MOUNT® MULTIVERSAL EXTRICATION TOOL HOLDER
MODEL QM-ET-MV
PARTS AND INSTRUCTION MANUAL

The QM-ET-MV holds many popular makes and models of extrication tool securely, upright in the compartment.

Fully adjustable, the various components slide to fit your individual tool. Tilt angle is also adjustable.

Replace tools fairly often? Simply readjust the holder.

Made with heavy-duty, light weight aluminum.

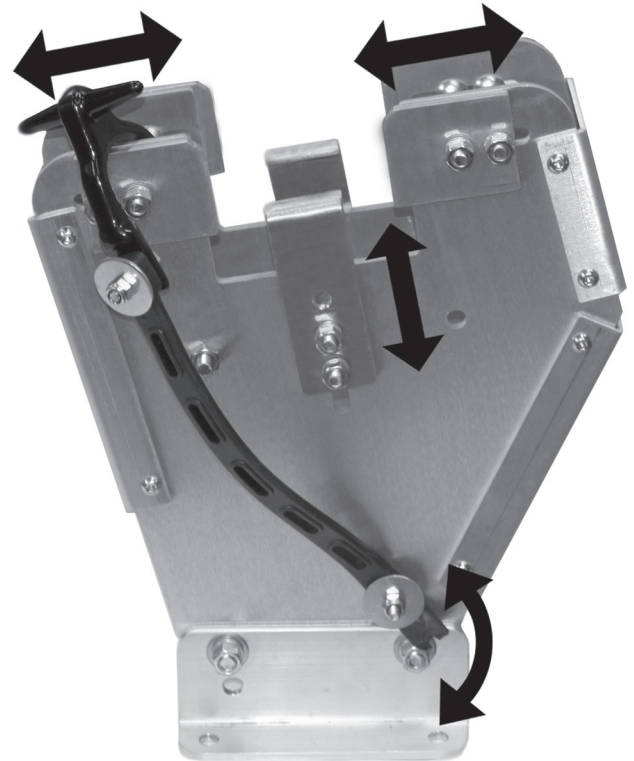

MODEL	DESCRIPTION	WT./@ IN LBS.
QM-ET-MV	Multiversal Extrication Tool Holder	8.6

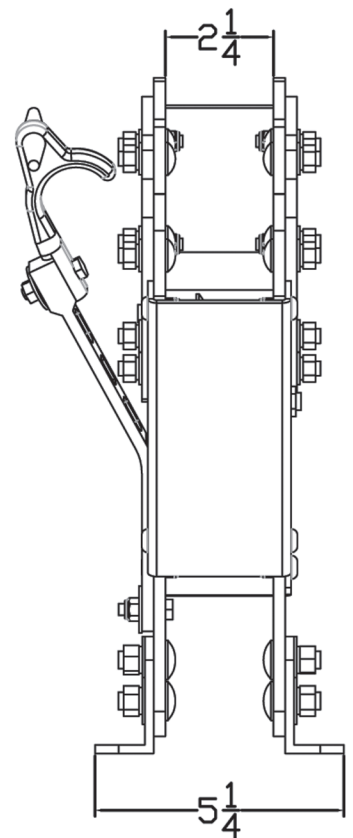
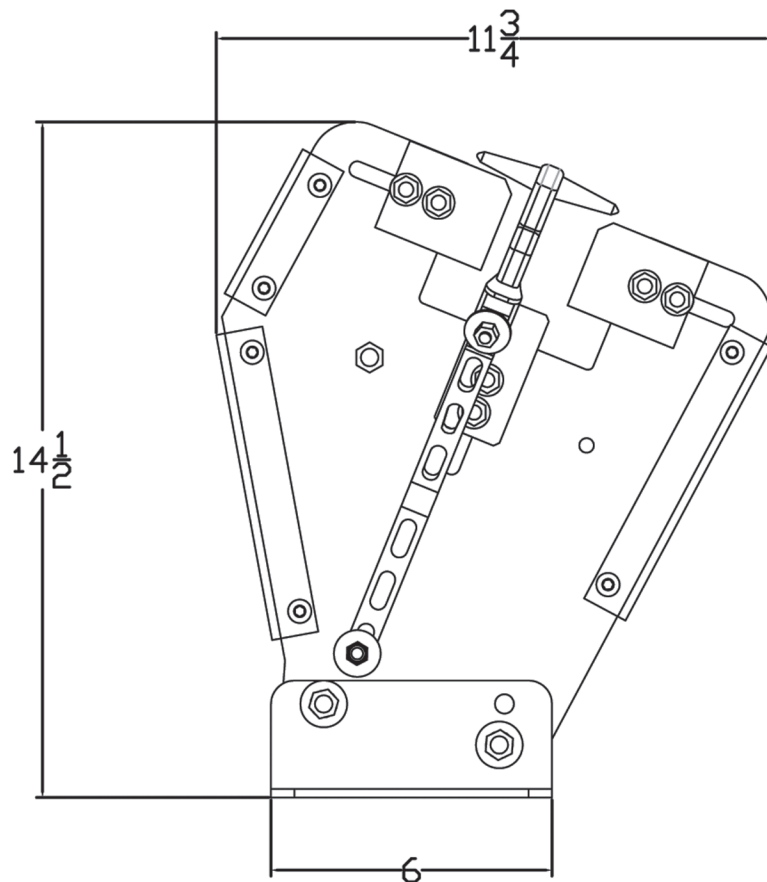

Parts Diagrams - QM-ET-MV

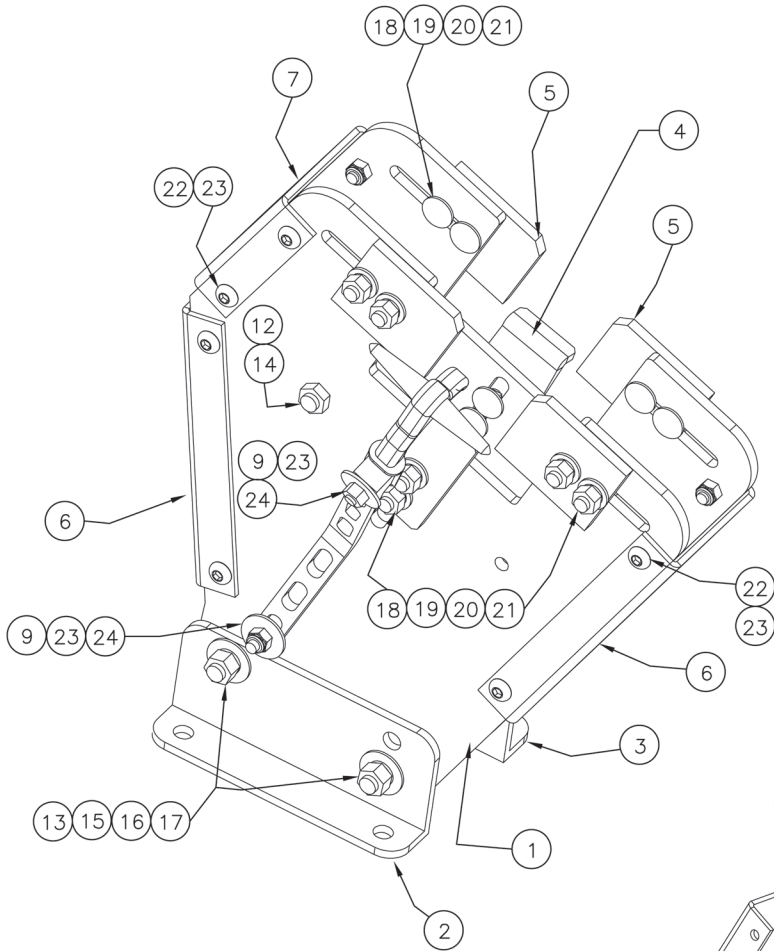

Isometric View

Exploded View

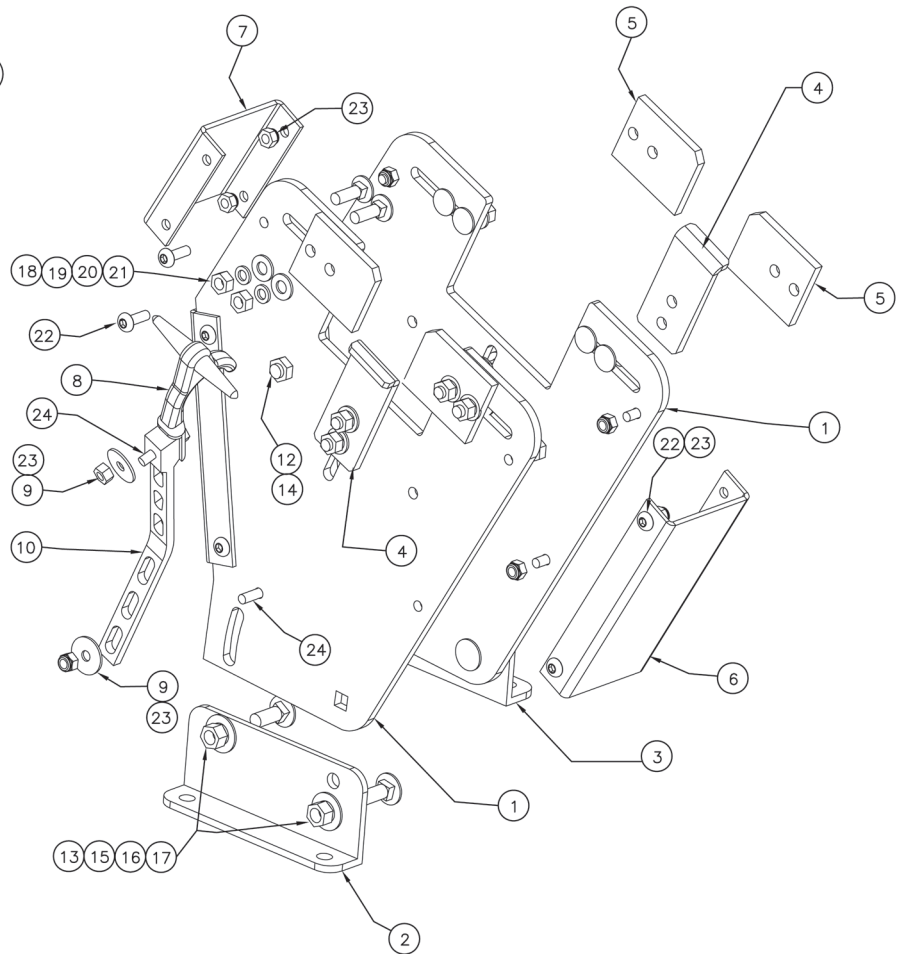

Parts Breakdown - QM-ET-MV

ITEM #	PART #	DESCRIPTION	QTY.
1	3095-235-101	Vertical Box Plate	2
2	3095-235-103	Vertical Box Mounting Angle Left	1
3	3095-235-105	Vertical Box Mounting Angle Right	1
4	3095-235-107	Vertical Box Center Adjuster w/Tab	2
5	3095-235-109	Vertical Box Side Adjuster	4
6	3095-235-111	Vertical Box Long Channel	2
7	3095-235-113	Vertical Box Short Channel	1
8	3095-215-109	Strap Handle	1
9	9014-162500	Washer, 1/4" Wide	2
10	3095-215-107	EPDM Rubber Strap	1
12	9015-633720	3/8"-16 x 1.25" Carriage Bolt, G5-5 ZPS	2
13	9015-633716	3/8"-16 x 1" Carriage Bolt, G5-5 ZPS	4
14	9012-203700	3/8"-16 Jam Nut ZPS	4
15	9014-113700	3/8" Flat Washer ZPS	4
16	9014-203700	3/8" Split Lock Washer ZPS	4
17	9012-103700	3/8"-16 Nut, ZPS	4
18	9015-633116	5/16"-18 x 1" Carriage Bolt, G5-5 ZPS	12
19	9014-103100	5/16" Flat Washer (5/16 x 9/16 x 1/16)	12
20	9014-203100	5/16" Split Lock Washer, ZPS	12
21	9012-103100	5/16"-18 Nut, ZPS	12
22	9010-502512	1/4"-20 x 3/4" Button Cap Screw, ZPS	12
23	9013-172500	1/4"-20 Nylock Nut, ZPS	14
24	9015-102520	1/4"-20 x 1-1/4" Hex Head Bolt, ZPS	2

Adjustment Instructions

Note: Part numbers in parentheses. Refer to page 3.

Set-up: Adjustment is most easily accomplished with the QM-ET-MV out of the compartment and in full upright position (as shipped).

1. Place tool you wish to mount completely into the holder. For wider tools, position the Vertical Box Long Channels (6) and Vertical Box Short Channel (7) against the inner sides of the Vertical Box Plates (1). Set Center Adjusters (4) to achieve max engagement with tool while keeping weight off of vinyl hand guard. If you adjusted the Channels for a wider tool, you may need to rotate the Center Adjuster (4) tabs to the inside to achieve proper engagement.
2. Set Side Adjusters (5) to center the tool with a minimum of side play at frame yoke.
3. Set Blade Offset stop bolts (12) to square the tool in box.
4. Adjust tilt angle at mounting flanges (13) as desired.
5. Adjust Strap Handle (8) and Rubber Strap (10) to secure tool.

Mounting Instructions

Mount at four points using 3/8" hardware (not included).



Ziamatic Corp.

10 West College Avenue, P.O. Box 337, Yardley, PA 19067-0587 • (215) 493-3618 • FAX: (215) 493-1401

www.ziamatic.com

TOLL FREE: 800-711-3473

*ZICO is a registered trademark for fire, safety and marine products made by Ziamatic Corp.

Copyright Ziamatic Corp. 6-12