



Fire, Safety, and Marine Equipment
10 West College Ave., Yardley, PA, 19067-8337
(215) 493-3618 • 1-800-711-FIRE • FAX (215) 493-1401
www.ziamatic.com e-mail: zservice@ziamatic.com

QUIC-LIFT™ SYSTEMS

I. SYSTEMS AVAILABLE

Refer to combination chart (page 18) for the correct combination number for the ladders you are using. Then contact Ziamatic Corp. to ascertain the LAS system you require.

A. Ladder Access Systems (LAS):

Note: Model numbers carried suffix -03 until January 1, 1997, when it was dropped.

- | | | |
|----|----------|--|
| 1. | LAS-775 | Complete unit with 7-3/4" ladder support |
| 2. | LAS-975 | Complete unit with 9-3/4" ladder support |
| 3. | LAS-1200 | Complete unit with 12" ladder support |

B. Bulk Head Mounted Ladder Access Systems (LAS-BHM)

- | | | |
|----|--------------|--|
| 1. | LAS-BHM-775 | Complete unit with 7-3/4" ladder support |
| 2. | LAS-BHM-975 | Complete unit with 9-3/4" ladder support |
| 3. | LAS-BHM-1200 | Complete unit with 12" ladder support |

C. Hard Sleeve System (HSS)

- HSS-CWT-210 Hard sleeve system complete with two 10' aluminum trays

Note: HSS starts with basic LAS unit to which other components are added. See page 24 for adding one hard sleeve to a System.

D. Portable Tank Systems (PTS)

- | | | |
|----|---------|----------------------------------|
| 1. | PTS | Basic unit with 30-1/2" deep box |
| 2. | PTS-TCH | Tank cover hardware |

Note: Separate booklet (3098PM1) covers operation of the PTS System.

E. Horizontal Access Systems (HLAS)

- | | |
|----|-----------|
| 1. | HLAS-775 |
| 2. | HLAS-975 |
| 3. | HLAS-1200 |
| 4. | HPTS |

Note: Separate booklet (3097PM6) covers operation of the HLAS System.

II. Standard Equipment

The following items are included with each complete LAS or HSS System:

A. Instruction Packet

Includes all information required to install a complete System. Wiring diagrams and parts lists are provided.

B. Control Switch - Model No. LAS-CHS (P/N 3097-105-144)

A double-pole double-throw momentary toggle switch is provided for operation of the System.

C. Flashing Light Kit - Model No. LAS-FLK (P/N 3097-270-000)

Prior to January 1, 1997, we provided an audio-visual alarm system (model LAS-AVA) with relay (P/N 3097-105-152). You may still purchase the audio-visual alarm (see P/N 8047-125-000, Model AVA) or the relay, but they are no longer part of the System. NFPA 1901-96 requires flashing lights. These lights must flash unless the System is in the stored position.

III. OPTIONAL EQUIPMENT

The following items may be added to any of the LAS or HSS Systems.

A. LAS-FLB

Brackets are to be mounted on top surface of pivot support casting (item 4, page 15 and pages 25, 27 & 28). Folding ladder bracket (FLB or FLBA) must be ordered in addition to the LAS-FLB castings. This option allows you to carry a folding ladder in addition to your ladders or hard sleeves.

B. HSS-TMC

Tray mounting castings allow you to carry one length of hard sleeve in addition to your ladders (LAS) or two lengths of hard sleeve (HSS). These castings mount on top of the LAS-FLB castings, which must also be ordered with this option (item H3, page 24 and pages 25, 26 & 27) along with tray mount hardware (HSS-TMH) and a 10 foot tray (HSS-SAT-10).

Note: Failure to mount the hard sleeve tray using our tray mount casting (HSS-TMC) and tray mount hardware (HSS-TMH) will void your warranty. See Figure 13, page 25 for mounting information.

C. LAS-FLB/PPMB

This square tube mount may also be used in conjunction with the LAS-FLB castings. This option allows mounting of pike pole mounting brackets in addition to folding ladder brackets. May not be used if option D is used (Figure 18, page 28).

D. PPMB-___

Pike pole mounting brackets may be attached directly using pre-drilled holes on the top side of the inside arm castings (item 2, page 15 and Figure 19, page 28). Either single or double mounts may be used. Refer to the current ZICO catalog to order the pike pole mounting brackets required. This option may not be used if option C is selected.

E. 1-1/2" Spacer Set (P/N 3097-250-000)

In some instances the Ladder Access Systems must be raised up to accommodate extra-wide ladders. When this occurs, a set of four 1-1/2" high spacers will be required (item 57, page 15) for proper mounting of the ladders. Required whenever the 27" long channel (item 54, page 15) is needed (see Chart 3, page 18).

F. LAS-LGK

Ladder guard kit contains one tube of epoxy and two stainless steel guards. The guards may be attached to the ladder rungs to prevent wear and possible damage as the result of the locking handle's contact with the rung (see Figure 30, page 39).

G. LLAS-MLS or LLAS-BHM-MLS

The manual locking system (Figure 24, page 33) provides a positive means of retaining the ladders. The base casting for the LAS System was changed to add a new higher center section to accommodate a locking system. We started shipping LAS Systems with the new base casting on March 23, 1998. LAS-BHM Systems have been using a new base casting since September 16, 1998. The lock must be de-activated prior to operating the electrical control. This is done by pulling outward on the strap (item 99, page 33) or pushing back on the handle (item 77, page 33).

H. LLAS-ELS or LLAS-BHM-ELS

The electric locking system (Figure 27, page 36) is activated by pressing down on the operating switch allowing the small electric actuators to open the locking mechanisms. After a momentary delay, the main electric actuators lower the System. The electric locking system may also be operated manually (see page 36).

IV. GENERAL INSTALLATION INFORMATION

The Ladder Access System was designed for ladders meeting the current NFPA 1931 standard. Systems accommodate most ladder combinations. However, for ladders over 35 feet or with tormentor poles, contact Ziamatic Corp. to ascertain if they may be used with an Access System. Combinations (see page 18) 36, 44, 53, 63, 72, 80, 126, 128, 129, 130, 132, 133, 144, 152, 154, 157, 158, and 159 require ladder mounts in excess of 12 inches. Some of these combinations may be accommodated by adding spacers behind the ladder mount and retainer handle support, but this increases the mounting depth and the ladders may protrude excessively beyond the side of the vehicle. We do not recommend mounting of these ladders.

Note: The weight of ladders and/or hard sleeves may not exceed 300 pounds with any of the Ladder Access Systems. We recommend the manual or electric locking systems (see pages 33 through 38) be used whenever a hard sleeve tray is mounted over the LAS or HSS System.

A. Mounting Points

The Ladder Access devices should be placed symmetrically in reference to the ladder. The same number of rungs should extend past each ladder support (page 23). This will ensure that both units are lifting approximately the same weight (if this is not possible, contact Ziamatic Corp.). Bolt holes have been provided on both the vertical and horizontal mounting surfaces. Although the device may be securely mounted from the horizontal surface only, it is a great advantage to be able to use mounting bolts on the vertical surface as well. One-half inch thick backing plates should be used if using only vertical or horizontal hole sets for mounting (see Section V.A., last paragraph). Bulk Head Mount units must have backing plates and can only be mounted to a vertical surface.

All bolts should have reinforcement structure added underneath the mounting surface where possible. Channel or rectangular tube should be used instead of flat plate as reinforcement. If aluminum plate is used, it should be 1/2" thick (see page 21).

B. Electrical Circuit

The control switch should be a momentary double-pole double-throw exterior 30 amp switch. We provide a switch with each system. It should be placed in such a position that the operator has full view of the QUIC-LIFT System and personnel that might come in contact with it. Using wires of equal length between power source and actuators will help to keep the actuators running in synchronization (see page 22 for wiring diagrams).

B. Electrical Circuit (continued)

Several "Lock Out" circuits may be considered to prevent accidents from occurring. An ideal "Lock Out" system would only permit operation when the ignition switch is on, the transmission is in park, and any obstructing compartment doors are shut. Because of the higher amperage required to operate the QUIC-LIFT System, a separate "Lock Out" circuit should be used (see electrical diagrams on page 22). The "Lock Out" circuit should be separated from the QUIC-LIFT System circuit by a relay. This will prevent damage to the existing wiring system. The QUIC-LIFT System circuit should be protected by a 30 amp fuse.

NFPA 1901-96 standard requires flashing lights to be provided, facing front and rear of the apparatus. Lights must flash whenever the System is out of the stored position. The flashing light kit (model LAS-FLK) was added to all Systems beginning January 1, 1997 (see pages 29 & 30). Prior to that, we provided an audio-visual alarm and relay. The audio visual alarm may still be ordered as an option (see model AVA, P/N 8047-125-000 in catalog).

C. Synchronization of Actuators

As noted under "Trouble Shooting" (Section VI. C.) all electric actuators are timed, under load, and the times are recorded. If you experience any problems associated with the electric actuators, we will require the serial number off of your device (see pages 15 and 17 for location of serial number).

It is important to the operation of the QUIC-LIFT System that the actuators work in synchronization. The actuators may be out of sync a considerable amount before binding occurs, however, reducing the occurrence of this will increase the life of the actuators and prevent damage or wear to the ladders. Keeping the load evenly distributed on the two devices will help to keep the actuators running in synchronization (Figure 9, page 23).

Do not permit personnel to hang, sit or stand on ladders or hose while stored on the QUIC-LIFT System. If the unit is overloaded, the internal clutch will slip and prevent damage to the actuators.

When the operator raises or lowers the unit, he should let it run until he hears both clutches start to slip so that the actuators re-synchronize and are ready to run in the opposite direction.

We have extensively tested our QUIC-LIFT System and have found the normal life to be in excess of 5,000 cycles without failure. With reasonable care and maintenance, your QUIC-LIFT System should give you many years of excellent service.

V. INSTALLING THE LADDER ACCESS SYSTEM

A. Preparation for Mounting

Plan and lay out the entire installation before making any cuts or drilling holes in the body of the fire apparatus. This will keep "out of service" time to a minimum and also help to minimize mistakes. See Electrical System below before any holes are drilled into the apparatus.

Lay the two units on the shelf of the apparatus so that you can see where holes will be required for the mounting bolts. There should be sufficiently sized flat surface underneath the mounting holes free of seams and obstructions where the bolts will pass through. Raise the ladders near the two units to determine where they will lay when installed. The ladders must be evenly supported by each unit (the same number of rungs should extend on the outer side of each ladder support).

When the ladder is raised and lowered in this position, it should clear protruding objects on the apparatus such as emergency lights, hand rails, etc. Make sure that when the ladders are in the up position they do not obstruct cross lays or hose reels.

Measure the "resting" depth of your ladder combination to determine how far your ladders will protrude out from the hose bed wall (add depth of 6" for the retracted LAS System). In the event that the actuator retainer casting (item 48, page 15) or inner arm casting (item 2, page 15) come into contact with the stiffening rib at the top of the hose bed, you may have to notch out the stiffening rib to recess the device (see page 21). In the event that the stiffening rib is notched, the exposed metal surfaces should be painted and covered with an edge guard material. In addition, and in particular, if the stiffening rib is notched, you may wish to add a backing plate (page 21) on the inside surface of the hose bed wall. The plate will reinforce the hose bed wall and provide a good mounting support for the QUIC-LIFT System. The edges should be rounded off, on the side next to the hose, and flat head bolts should be used to mount the plate.

Bolts 3/8" or larger should be used to mount the base castings to the fire apparatus. When the bases will only be mounted to the hose bed wall or only mounted to the shelf deck, 1/2" bolts should be used with substantial backing plates (page 21) and supports. If you are installing the QUIC-LIFT devices to only one surface, we suggest you contact one of our technicians before beginning.

B Electrical System

Now that you are sure of your mounting position, you may begin to lay out your electrical wiring (pages 22, 29, 37 and 38). At this time, it is a good idea to remove the units from the shelf and "C" clamp them to a table so that the units will swing out away from the table when lowered. Units should be mounted the same distance back from edge of table as they would be on the shelf of your apparatus. Be sure the table is secured by adding a counterweight to the other side before lowering the units. Place ladders onto the ladder mount castings (item 7, page 15) just as they will be stored on the apparatus. Determine where wires can be run so they will not be visible from the outside of the apparatus. We recommend all electrical connections be soldered as this method is superior to crimp connections. Measure the required run lengths of each wire (see page 22 for proper wire diameter).

Make up a wiring harness using wires longer than the required run lengths. Temporarily make all wire connections so you can test the system. With the table properly secured, you should be able to operate the units with the ladders or hard sleeves attached. Be sure the ladders will clear the edge of the table before drilling any holes in the apparatus. If they do not, spacers may be required (see Section III, E., page 3).

The flashing light kit (model LAS-FLK) must be installed. The wiring diagram for the flashing lights may be found on page 29.

C. Mounting Suggestions

A "WARNING" label (part number 3097-105-149, item 49, page 14) is supplied with each QUIC-LIFT System. The pressure sensitive label must be mounted by the electrical control switch. All apparatus operators must be instructed to keep area in front of ladders clear of personnel when the QUIC-LIFT System is being raised or lowered.

Before starting the installation, you should make sure you have all necessary tools and materials. This should include matching touch-up paint, edge trim (for cut outs), fender protector cloths and removable tape (to protect paint), necessary hardware, wire connectors, cable ties, burr remover, vacuum cleaner (for metal filings), edge guards (for wiring), drills, drill gun, wrenches, step ladders, etc. Be sure to allow yourself sufficient time to make a proper installation. You will probably have to remove the hose from the hose bed.

Following these simple instructions should make your installation easy and professional.

VI. TROUBLE SHOOTING

All units are tested after final assembly to ensure proper operation and adjustment. No further adjustments should be required unless excess vibration is noted (see VI. D., page 9).

A. Actuator "Creeping Down"

An indicator light may be installed in the cab of your vehicle to warn the driver when the System is out of the stored position. If this light comes on while the vehicle is in motion, it may be an indicator that one of the electric actuators is "creeping down". The actuator will not drop suddenly but the driver should keep an eye on the System until he reaches his destination. Then the switch may be activated to retract the System to the stored position.

Under certain road conditions, the frequency of vibrations may cause the friction brake within the electric actuator to slip. This in turn may allow the motor to turn and the worm gear to retract or "back drive". The same problem may occur when a hard sleeve is mounted above the ladders and/or hard sleeves.

If your System "creeps down", we suggest you add the manual locking system (Figure 24, page 33) or electric locking system (Figure 27, page 36) to your System (see III. G. & H., page 3).

B. Ladder Wider Than Ladder Support

If the proper ladder combination is specified at the time of ordering, this problem should not occur. The standard support channel (item 54, page 15) is 25-1/4" long. We can also provide a longer support channel (part number 3097-105-155) which is 27" long. See Chart 3, page 18, for combinations requiring the 27" long channel. Spacer set (part number 3097-250-000) must be ordered with these combinations.

C. One Actuator Running Two Or More Seconds Slower Than The Other

All actuators are timed, under load, at the factory with the times recorded. We match up electric actuators with as close to equal times as possible when assembling a QUIC-LIFT System. When one actuator is running more than two seconds behind the other, it is normally due to some type of resistance in the wiring system. Check all wire connections to make sure they are secure. Make sure to ratchet both actuators at the end of each up and down cycle. If they are still greatly out of synch, after checking the wiring and ratcheting the units at the end of each cycle, you may switch the actuators to confirm if the problem is in the wiring system. After removing the ladders, remove the retainer pin (item 9, page 15) from each unit and nut/bolt assembly (items 10, 16 and 42, page 15) to remove the actuator. Switch the two actuators and reassemble. If the rear actuator was running slower before switching and is still running slower, there is a problem in the wiring.

D. Excess Vibration May Cause Failure Of One Or More Castings

A "WARNING" label (part number 3097-105-158, item 58, page 14) has been attached to each set of castings. If, after installing the System and ladders, you note excessive movement of the ladders while operating the vehicle, check the following (referring to drawings on pages 11 & 15 and bill of materials on page 14 and information provided below). Remove the ladders before proceeding.

1. Actuator Retainer Adjustment (see Figure 1, page 11)

a. Check hex head bolts (items 46 and 47) to see if either one is loose. If one or both are loose, proceed as follows. If they are tight, proceed to Section VI. D. 2.

b. To adjust (refer to Chart 2, page 14 for item numbers in parenthesis):

1. Lower system approximately one-half way down and remove ladders.

2. Loosen locking nut (6) and turn hex head bolt (5) all the way in to the inside arm casting (2)

3. Snip and remove locking wire (53).

4. Raise the unit until the electric actuator is fully extended and the clutch ratchets. In the raised, or stored position, the inside arm casting should be almost parallel with hose bed wall (actually 1 to 2 degrees less than parallel).

5. Lower unit to provide better adjustment access. Loosen jack bolt (46) and adjust tension bolt (47).

- To increase outward lean, turn out on tension bolt (47)
- To decrease outward lean, turn in on tension bolt (47)

6. Re-tighten jack bolt (46) and raise unit completely to check adjustment.

7. When both bolts are tight and the outward lean of the inside arm casting (2) is 1 to 2 degrees, the adjustment of the actuator retainer is complete.

8. Replace safety wire.

9. Now re-adjust the Adjustment Stop (5 and 6). See Section VI. D. 2.

2. Adjustment Stop (see Figure 2, page 11)

a. Check bolt (5) and locking nut (6) to see if they are tight. If loose, proceed as follows:

b. To adjust:

1. Lower the unit partially, loosen locking nut and turn hex head bolt in, one or two turns, towards the inside arm casting.

2. Raise the unit to the full up position.

3. Turn out on the bolt (5) until it is lightly snugged against the outside arm casting (3).

4. Lower the device partially and turn hex head bolt out an additional 3/4 turn. Hold bolt in this position and tighten locking nut.

When the devices are returned to the upright, closed position, they should be rigid and not move with hand pressure.

E. Emergency Operation

If the System fails to lower from the stored position, do not attempt to repair until the unit is returned to the station.

If the System fails to raise from the down position, the following emergency procedure may be used:

1. Remove the ladders for transport back to the station.

2. With one person holding the ladder mount casting (7), a second person should pull the detent pin (39).

3. Lift unit to stored position and secure in place.

4. Replace detent pin.

5. Follow same procedure for the second unit.

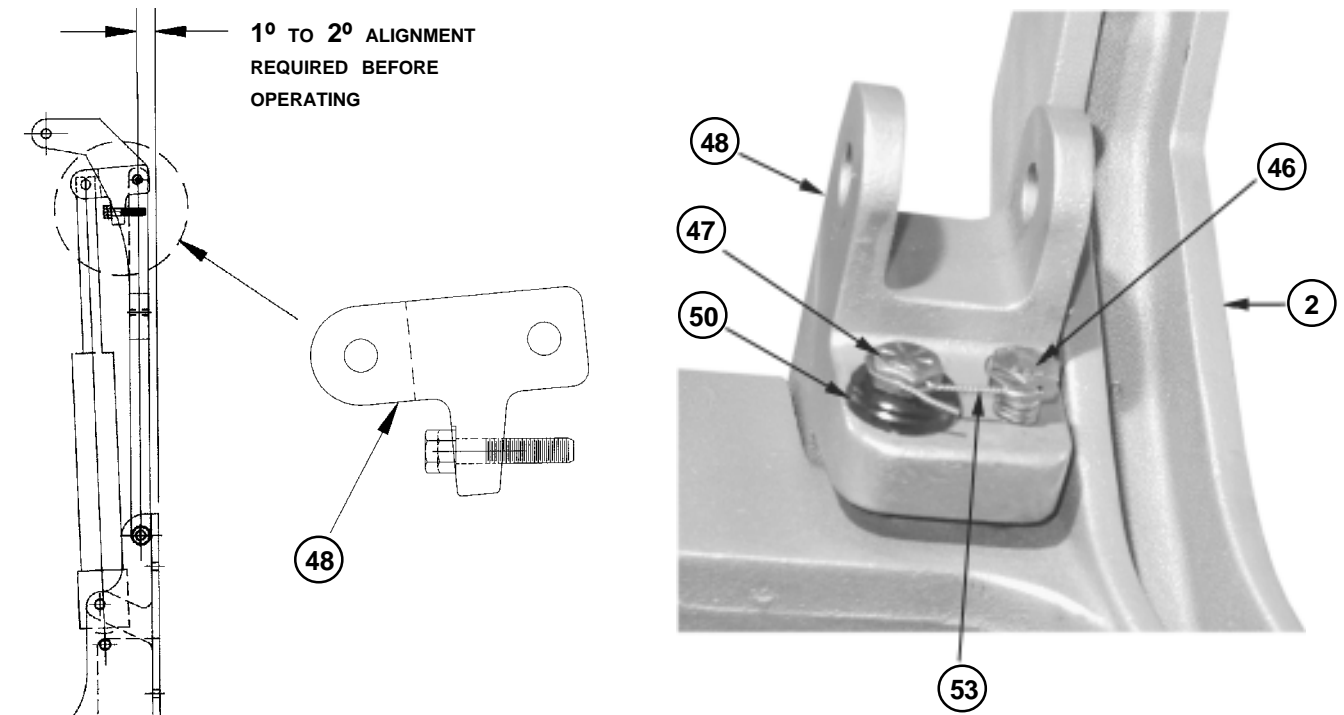


FIGURE 1
ACTUATOR RETAINER ADJUSTMENT (See Section VI. D. 1.)

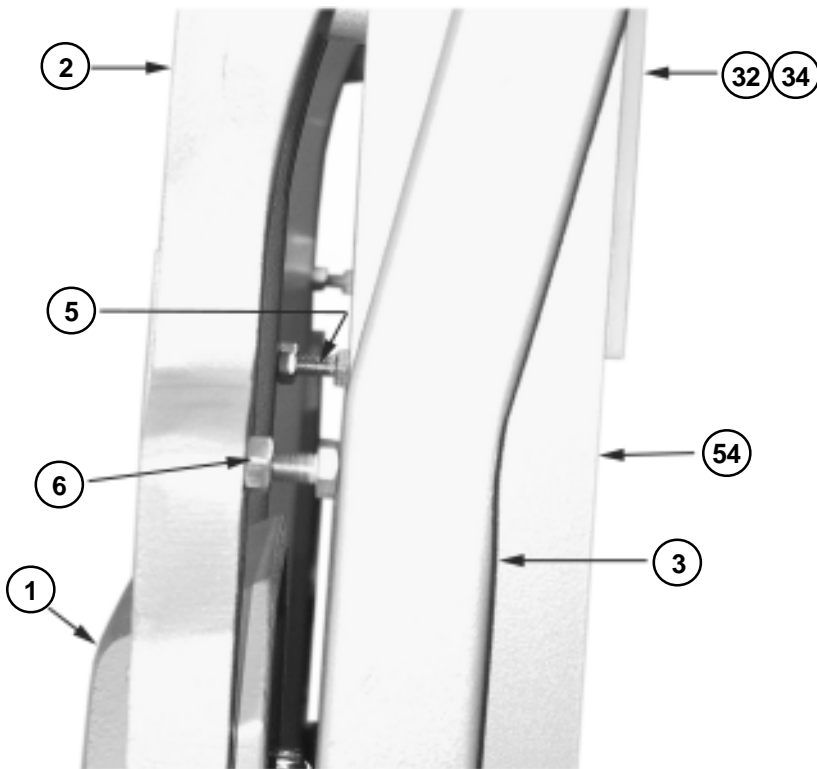


FIGURE 2
ADJUSTMENT STOP (See Section VI. D. 2.)

VII. DRAWINGS, DIAGRAMS AND CHARTS

A. Ladder Access System (LAS)

1. Actuator retainer adjustment (Figure 1, page 11)
2. Adjustment stop (Figure 2, page 11)
3. Combination numbers for LAS Systems (Chart 3, page 18)
4. Standard model shown with optional spacer blocks under base casting (Figure 3, page 15)
5. Parts list - Model LAS-____ (Chart 1, page 14)
6. Side view - Model LAS-____ (Figure 5, page 19)
7. Common installation using stiffening/backing plate (Figure 7, page 21)
8. Electrical diagram for QUIC-LIFT Systems (Figure 8, page 22)
9. Front view of LAS System (Figure 9, page 23)
10. Handle assembly (Figure 22, page 31)

B. Bulk Head Ladder Access System (LAS-BHM)

1. Bulk head mount for mounting on vertical surface only (Figure 4, page 17)
2. Parts list - Model LAS-BHM-____ (Chart 2, page 16)
3. Side view - Model LAS-BHM-____ (Figure 6, page 20)

C. Hard Sleeve System (HSS)

1. Frontal view of HSS system (Figure 10, page 23)
2. Model HSS hard sleeve system (Figure 11, page 24)
3. Model HSS parts list (Chart 4, page 24)
4. Hard sleeve system location and drilling instructions (Figure 13, page 25)
5. QUIC-STRAP system to retain hard sleeve (Figure 12, page 25 and Figure 14, page 26)
6. Hose tray support with hose tray (Figure 12, page 25 and Figure 15, page 26)

D. QUIC-LIFT System - Optional Equipment

1. Model LAS-FLB castings attached to pivot support casting (Figures 12 & 13, page 25, Figures 16 & 17, page 27 & Figure 18, page 28)
2. HSS-TMC tray mount castings (Figure 11 and Chart 4, page 24, Figure 12, page 25 and Figures 14 & 15, page 26)
3. Model LAS-FLB/PPMB extrusion added to support PPMB-AA or PPMB-BB (Figure 18, page 28)
4. Model PPMB-AA or PPMB-BB pike pole mounting brackets attached directly to inside arm castings (Figure 19, page 28)
5. Part Number 3097-250-000 spacer set under base casting (Figure 3, page 15)
6. Model LAS-FLK flashing light kit (pages 29 & 30)
7. Models LLAS-MLS and LLAS-BHM-MLS manual locking systems (pages 33 through 35)
8. Models LLAS-ELS and LLAS-BHM-ELS electric locking systems (pages 34 through 38)
9. Model LAS-LGK ladder guard kit (Figure 30, page 39)

VIII. MAINTENANCE

A. Periodic

Any time that ladders appear to be "loose", refer to Trouble Shooting (VI) and follow suggestions depending upon your specific problem.

B. Semi-Annually Or At Scheduled Apparatus Lube Service

1. Actuator retainer casting (item 48, pages 14 and 15) - If either bolt is loose, refer to adjustment directions (VI. D. 1., page 9 and Figure 1, page 11)
2. Adjustment stop (items 5 & 6, page 14 and 15) - If nut or bolt are loose, refer to adjustment directions (VI. D. 2., page 10 and Figure 2, page 11)
3. Lubrication - We suggest that all pivoting surfaces be sprayed, in the joints and pivot points, with CRC brand Stor&Lube, long-term lubricant and rust preventative #03032. Excess lubrication should be wiped off.
4. Electric actuator - We suggest the exposed shaft be cleaned and sprayed with WD40 or a similar light, moisture-repelling silicon type lubricant.

C. Pressure Washing

Do not operate pressure washer around or near the electric actuators. Excessive pressure may allow soap and water to blow past the seal, damaging the actuator.

IX. SERVICE

If you experience any problems with your Ladder Access System, please call us at 800-711-3473 for assistance. **Please have the serial number of your System available.** This number may be found on the lower front side of the base casting, where the casting is bolted to the mounting surface (see pages 15 & 17).

You may also refer to Chart 8, LAS Problem Solving, on page 41 for possible solutions for your questions.

X. WARRANTY

A copy of the warranty registration **MUST** be returned to ZICO to ensure registration of your System (page 44).

CHART 1. PARTS LIST

MODEL LAS-_____

ITEM NO.	PART NUMBER	NAME	MAT'L.	DESCRIPTION	MODEL NUMBERS			
					LAS BASIC	LAS 775	LAS 975	LAS 1200
1 ⁽¹⁾	3097-280-101	Base Casting	Alum		1	1	1	1
2	3097-105-102	Inside Arm Casting	Alum		1	1	1	1
3	3097-105-103	Outside Arm Casting	Alum		2	2	2	2
4	3097-105-104	Pivot Support Casting	Alum		1	1	1	1
5	9110-103124	Hex Hd Bolt	SST	5/16-18 x 1-1/2	2	2	2	2
6	9112-103100	Hex Hd Nut	SST	5/16-18	2	2	2	2
7	3097-165-107	Ladder Mount Casting	Alum	Size 9-3/4			1	
	3097-105-111	Ladder Mount Casting	Alum	Size 7-3/4		1		
	3097-105-135	Ladder Mount Casting	Alum	Size 12				1
8	3097-105-125	Retainer Housing, Short	Steel	}	Determined from 1 Ladder Combination			
	3097-165-125	Retainer Housing, Medium	Steel					
	3097-145-125	Retainer Housing, Long	Steel					
9	3097-105-115	Actuator Retainer Pin	SZP	1/2 Dia. x 5-3/8 Lg.	1	1	1	1
10	9010-315032	Shoulder Bolt (3/8-16)	SZP	1/2 x 2	1	1	1	1
11	9010-315024	Shoulder Bolt (3/8-16)	SZP	1/2 x 1-1/2	2	2	2	2
12	9010-315028	Shoulder Bolt (3/8-16)	SZP	1/2 x 1-3/4	2	2	2	2
13		Liquid Threadlocker*		As Required	A/R	A/R	A/R	A/R
14	9010-315012	Shoulder Bolt (3/8-16)	SZP	1/2 x 3/4	2	2	2	2
15	9010-315040	Shoulder Bolt (3/8-16)	SZP	1/2 x 2-1/2	2	2	2	2
16	9113-173700	Hex Hd Locknut	SST	3/8-16	7	7	7	7
17	9114-203700	LockWasher	SST	3/8 I.D.	6	8	8	8
18	3097-105-118	Hollow Lock Set Screw	STL	7/8-14		1	1	1
19	3097-105-119	Wear Strip	Plastic	7-5/8" Long		1		
	3097-165-119	Wear Strip	Plastic	9-3/4" Long			1	
	3097-145-119	Wear Strip	Plastic	12-1/16" Long				1
20	3097-105-120	Reflective Tape	P.S.			1	1	1
21	3097-105-121	Retaining Ring 1" OD	SZP			1	1	1
22	9110-333718	Socket Hd Cap Screw	SST	3/8-16 x 1-1/8	6	8	8	8
23 ⁽¹⁾	3097-105-114	Linear Actuator, Warner		Model D12-20B5-08	1	1	1	1
24	3097-105-109	Handle Casting	Alum			1	1	1
26	3097-105-126	Retainer Handle Support	Alum			1	1	1
27	90103350104	Socket Head C/S	SZP	1/2-13 x 6-1/2		1	1	1
28	3097-105-113	Compression Spring				1	1	1
29	9140-101220	Spring Pin	SST	1/8 Dia. x 1-1/4	1	1	1	1
30	3097-105-130	Nylon Washer	Plastic	1/2 ID x 3/4 OD x .062		1	1	1
32	3097-105-116	Ladder Pad	Plastic	1/8 Tk x 2 x 3		4	4	4
33	3097-105-133	Wiring Diagrams*		See Page 22	1	1	1	1
34	3097-105-161	Adhesive-Double Sided	P.S.	1 x 3 Use With Item 32	A/R	A/R	A/R	A/R
35	9010-333132	Screw	SZP	5/16-18 x 2		2	2	2
36	9010-333144	Screw	SZP	5/16-18 x 2-3/4		2	2	2
37	9013-133100	Self-Locking Hex Nut	SZP	5/16-18		4	4	4
38	3097-105-138	Label *Scotchlite	P.S.	"Pull Pin Below"	1	1	1	1
39 ⁽²⁾	9080-005040	Clevis Pin	SZP	1/2 Dia. x 2-1/2"	1	1	1	1
40	9014-115000	Flat Washer	SZP	1/2" I.D.	1	1	1	1
41	9070-001212	Cotter Pin	SZP	1/8 Dia. x 3/4	1	1	1	1
42	9114-113700	Flat Washer	SST	3/8 I.D.	7	7	7	7
43	9114-115000	Spacer	SST	3/8 I.D.	8	8	8	8
44	3097-105-144	Cole-Hersee Switch*		No. 055054	1	1	1	1
46	9110-453720	Hex Hd Bolt/Hole In Hd.	SST	3/8-16 x 1-1/4 / 1/16 Hole	1	1	1	1
47	9010-453732	Hex Hd Bolt/Hole In Hd.	SZP	3/8-16 x 2 / 1/16 Hole	1	1	1	1
48	3097-105-148	Actuator Retainer Casting	Alum		1	1	1	1
49	3097-105-149	Label* Scotchlite	P.S.	"Keep Clear Of Area"	1	1	1	1
50	9014-353700	Spher Washer Set (2 Pcs.)	STL	3/8 ID Black Oxide	1	1	1	1
53	3097-105-151	Wire Tie Type 302	SST	8" Lg.	1	1	1	1
54	3097-105-154	Channel Support	Alum	25-1/4 Long	1	1	1	1
	3097-105-155	Channel Support	Alum	27 Long	OPT	OPT	OPT	OPT
56	3097-270-000	Flashing Light Kit*		See Pages 29 & 30	1	1	1	1

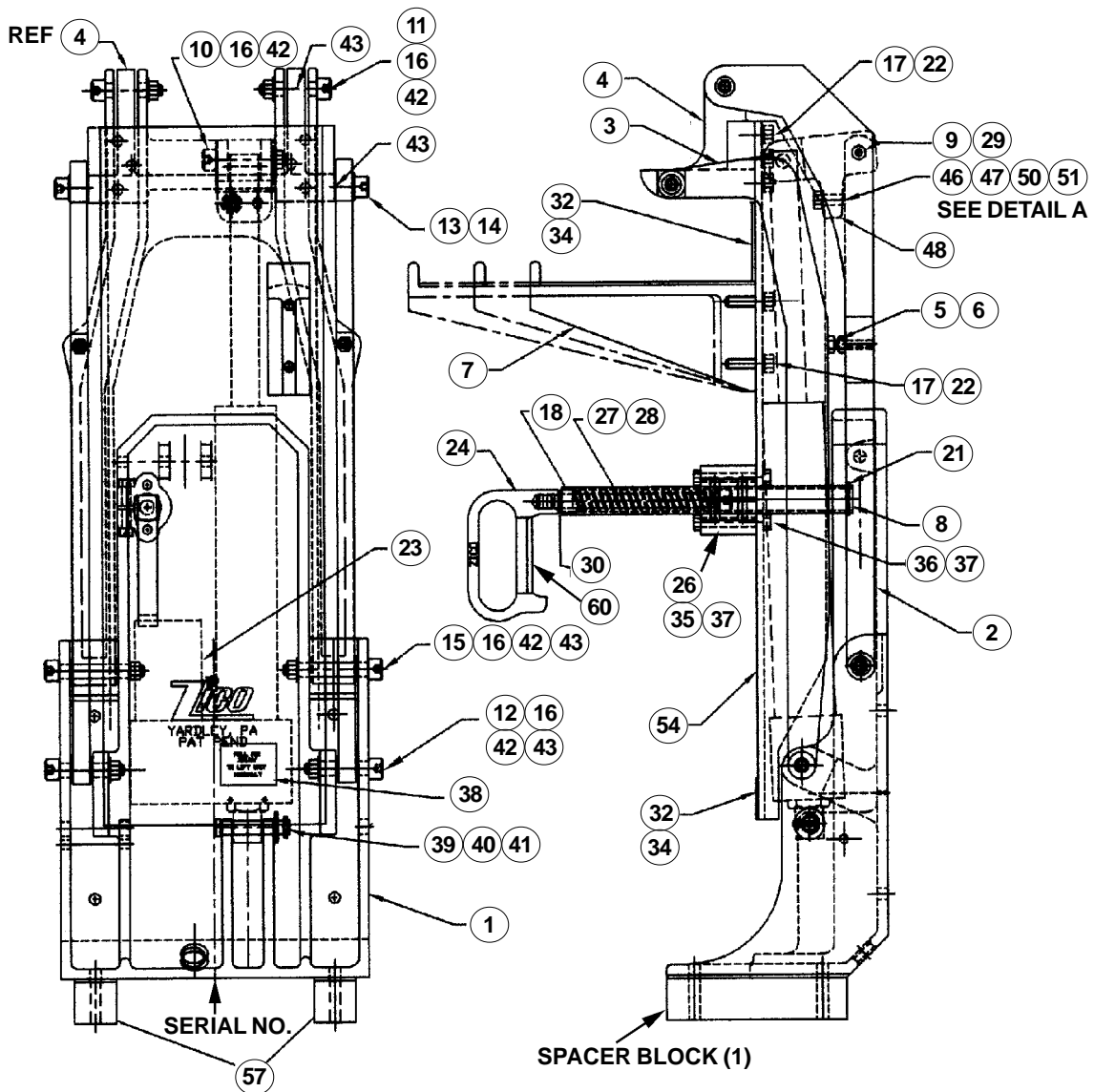
* = NOT SHOWN

A/R = AS REQUIRED

OPT = OPTIONAL

⁽¹⁾Serial No. required to order

⁽²⁾Item 39 was Detent Pin (9050-135090). Changed to Clevis Pin (9080-005040) on April 24, 2002.



**FIGURE 3. MODEL LAS-____
STANDARD MODEL SHOWN WITH OPTIONAL
SPACER BLOCKS UNDER BASE CASTING**

(1)PART NO. 3097-250-000 (SET OF 4) SPACER BLOCKS
SEE CHART 3 FOR COMBINATION NO.'S
REQUIRING SPACER BLOCKS

ITEM NO.	PART NUMBER	NAME	MAT'L.	DESCRIPTION	MODEL NUMBERS			
					LAS BASIC	LAS 775	LAS 975	LAS 1200
57	3097-105-157	Base Spacer (2 Required)	Alum	1-1/2 x 2-1/2 x 6-1/2	OPT	OPT	OPT	OPT
58	3097-105-158	Label* Scotchlite	P.S.	"Vibration Warning"	1	1	1	1
59	3097-105-159	Label* Scotchlite	P.S.	"Caution-Do Not Rigidly Conn."		1	1	1
60	3097-105-160	Wear Strip	PLSTC	Use With Item 24		1	1	1
62	3097-105-162	Label* Orange	P.S.	"To Prevent Wear"		1	1	1
63	3097-105-163	Label*	Paper	"Factory Set"		1	1	1

CHART 2. PARTS LIST MODEL LAS-BHM-_____

ITEM NO.	PART NUMBER	NAME	MAT'L.	DESCRIPTION	MODEL NUMBERS			
					LAS-BHM-BASIC	LAS-BHM-775	LAS-BHM-975	LAS-BHM-1200
1 ⁽¹⁾	3097-107-101	Base Casting	Alum		1	1	1	1
2	3097-105-102	Inside Arm Casting	Alum		1	1	1	1
3	3097-105-103	Outside Arm Casting	Alum		2	2	2	2
4	3097-105-104	Pivot Support Casting	Alum		1	1	1	1
5	9110-103124	Hex Hd Bolt	SST	5/16-18 x 1-1/2	2	2	2	2
6	9112-103100	Hex Hd Nut	SST	5/16-18	2	2	2	2
7	3097-165-107	Ladder Mount Casting	Alum	Size 9-3/4			1	
	3097-105-111	Ladder Mount Casting	Alum	Size 7-3/4		1		
	3097-105-135	Ladder Mount Casting	Alum	Size 12				1
8	3097-105-125	Retainer Housing, Short	Steel	}	Determined from 1 Ladder Combination			
	3097-165-125	Retainer Housing, Medium	Steel					
	3097-145-125	Retainer Housing, Long	Steel					
9	3097-105-115	Actuator Retainer Pin	SZP	1/2 Dia. x 5-3/8 Lg.	1	1	1	1
10	9010-315032	Shoulder Bolt (3/8-16)	SZP	1/2 x 2	1	1	1	1
11	9010-315024	Shoulder Bolt (3/8-16)	SZP	1/2 x 1-1/2	2	2	2	2
12	9010-315028	Shoulder Bolt (3/8-16)	SZP	1/2 x 1-3/4	2	2	2	2
13		Liquid Threadlocker*		As Required	A/R	A/R	A/R	A/R
14	9010-315012	Shoulder Bolt (3/8-16)	SZP	1/2 x 3/4	2	2	2	2
15	9010-315040	Shoulder Bolt (3/8-16)	SZP	1/2 x 2-1/2	2	2	2	2
16	9113-173700	Hex Hd Locknut	SST	3/8-16	7	7	7	7
17	9114-203700	LockWasher	SST	3/8 I.D.	6	8	8	8
18	3097-105-118	Hollow Lock Set Screw	STL	7/8-14		1	1	1
19	3097-105-119	Wear Strip	Plastic	7-5/8" Long		1		
	3097-165-119	Wear Strip	Plastic	9-3/4" Long			1	
	3097-145-119	Wear Strip	Plastic	12-1/16" Long				1
20	3097-105-120	Reflective Tape	P.S.			1	1	1
21	3097-105-121	Retaining Ring 1" OD	SZP			1	1	1
22	9110-333718	Socket Hd Cap Screw	SST	3/8-16 x 1-1/8	6	8	8	8
23 ⁽¹⁾	3097-105-114	Linear Actuator, Warner		Model D12-20B5-08	1	1	1	1
24	3097-105-109	Handle Casting	Alum			1	1	1
26	3097-105-126	Retainer Handle Support	Alum			1	1	1
27	90103350104	Socket Head C/S	SZP	1/2-13 x 6-1/2		1	1	1
28	3097-105-113	Compression Spring				1	1	1
29	9140-101220	Spring Pin	SST	1/8 Dia. x 1-1/4	1	1	1	1
30	3097-105-130	Nylon Washer	Plastic	1/2 I.D. x 3/4 O.D. x .062		1	1	1
32	3097-105-116	Ladder Pad	Plastic	1/8 Tk x 2 x 3		4	4	4
33	3097-105-133	Wiring Diagram*		See Page 22	1	1	1	1
34	3097-105-161	Adhesive-Double Sided	P.S.	1 x 3 Use With Item 32	A/R	A/R	A/R	A/R
35	9010-333132	Screw	SZP	5/16-18 x 2		2	2	2
36	9010-333144	Screw	SZP	5/16-18 x 2-3/4		2	2	2
37	9013-133100	Self-Locking Hex Nut	SZP	5/16-18		4	4	4
38	3097-105-138	Label *Scotchlite	P.S.	"Pull Pin Below"	1	1	1	1
39 ⁽²⁾	9050-005040	Clevis Pin	SZP	1/2 Dia x 2-1/2	1	1	1	1
40	9014-115000	Flat Washer	SZP	1/2" I.D.	1	1	1	1
41	9070-001212	Cotter Pin	SZP	1/8 Dia. x 3/4	1	1	1	1
42	9114-113700	Flat Washer	SST	3/8 I.D.	7	7	7	7
43	9114-115000	Spacer	SST	3/8 I.D.	8	8	8	8
44	3097-105-144	Cole-Hersee Switch*		No. 055054	1	1	1	1
46	9110-453720	Hex Hd Bolt/Hole In Hd.	SST	3/8-16 x 1-1/4 / 1/16" Hole	1	1	1	1
47	9010-453732	Hex Hd Bolt/Hole In Hd.	SZP	3/8-16 x 2 / 1/16" Hole	1	1	1	1
48	3097-105-148	Actuator Retainer Casting	Alum		1	1	1	1
49	3097-105-149	Label* Scotchlite	P.S.	"Keep Clear Of Area"	1	1	1	1
50	9014-353700	Spher Washer Set (2 Pcs.)	STL	3/8 ID Black Oxide	1	1	1	1
53	3097-105-153	Wire Tie Type 302	SST	8" Lg.	1	1	1	1
54	3097-105-154	Channel Support	Alum	25-1/4 Long	1	1	1	1
	3097-105-155	Channel Support	Alum	27 Long	OPT	OPT	OPT	OPT
56	3097-270-000	Flashing Light Kit*		See Pages 29 & 30	1	1	1	1

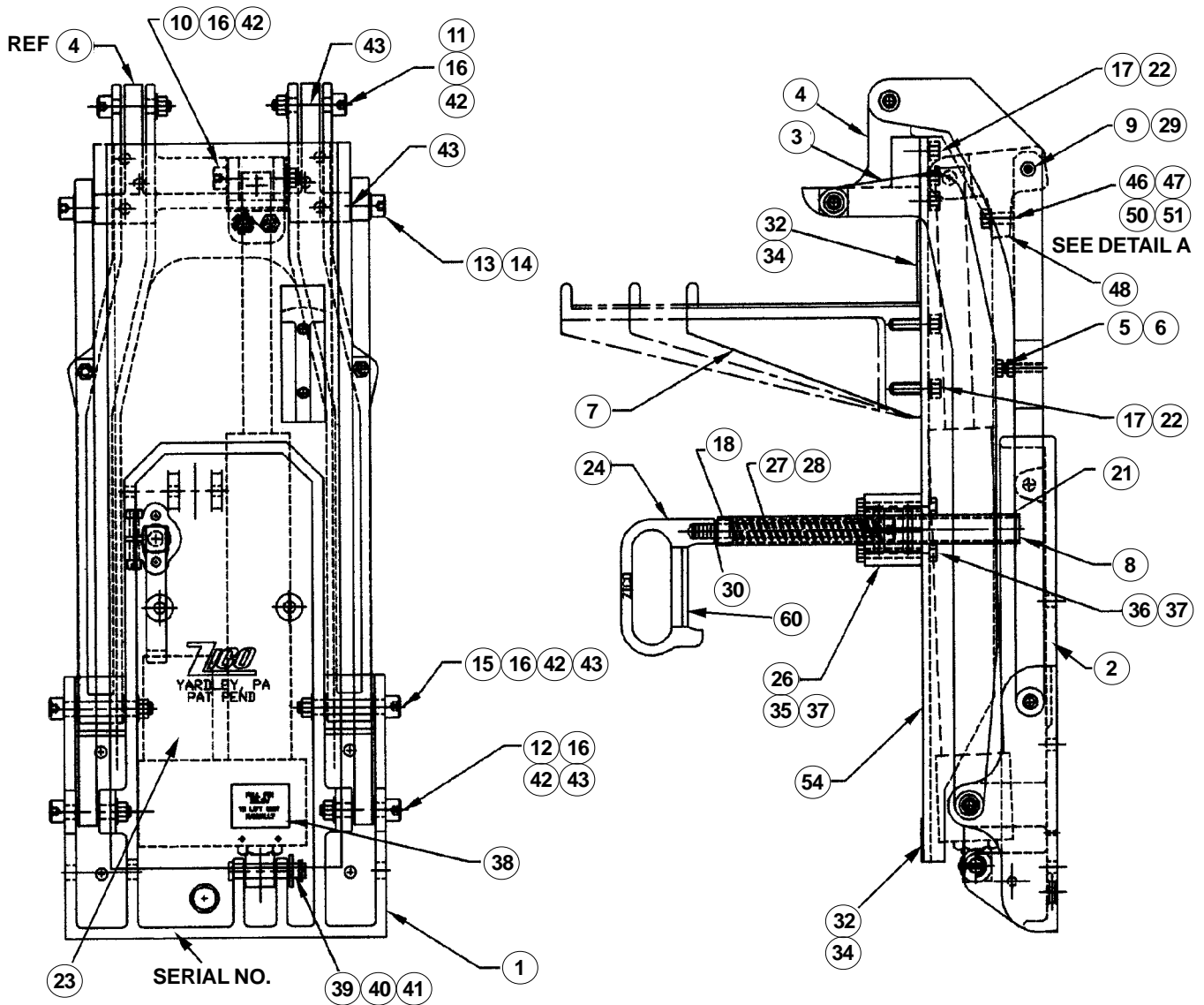
* = NOT SHOWN

A/R = AS REQUIRED

OPT = OPTIONAL

⁽¹⁾Serial No. required to order

⁽²⁾Item 39 was Detent Pin (9050-135090). Changed to Clevis Pin (9080-005040) on April 24, 2002.



**FIGURE 4. MODEL LAS-BHM-____
BULK HEAD MOUNT FOR MOUNTING ON
VERTICAL SURFACE ONLY**

ITEM NO.	PART NUMBER	NAME	MAT'L.	DESCRIPTION	MODEL NUMBERS			
					LAS-BHM-BASIC	LAS-BHM-775	LAS-BHM-975	LAS-BHM-1200
58	3097-105-158	Label* Scotchlite	P.S.	"Vibration Warning"	1	1	1	1
59	3097-105-159	Label* Scotchlite	P.S.	"Caution-Do Not Rigidly Connect"		1	1	1
60	3097-105-160	Wear Strip	PLSTC	Use With Item 24		1	1	1
62	3097-105-162	Label* Orange	P.S.	"To Prevent Wear"		1	1	1
63	3097-105-163	Label*	Paper	"Factory Set"		1	1	1

CHART 3 COMBINATION NUMBERS FOR LAS SYSTEMS

EXTENSION LADDER	ROOFLADDER											
		Alco Lite				Duo Safety						
		PRL 8' - 20' ALP-100 8'-20'	FRL 8' - 20' ALP-F-415 8'-20'	TRL 12' - 28' ALP-015 12'-28'	Y.G.R. 10'-20'	775 10'-14'	875 16'-20'	1275 25'-30'	575C 10'-25'	575C 30'		
Alco Lite 2 Section												
TEL 20' - 35' ALP-020 20'-35'		1	2	3	4 ⁽²⁾	5	6	7	8 ⁽²⁾	9 ⁽²⁾		
PEL 12' - 24' ALP-200-12'-24'		10	11	12	13	14	15	16	17	18		
PEL 28' - 35' ALP-200 28'-35'		19	20	21	22	23	24	25	26	27		
FEL 12' - 35' ALP-F-420 12'-35'		28	29	30	31	32	33	34	35 ⁽²⁾	(4)36 ⁽²⁾		
Alco Lite 3 Section												
TEL3 24' - 35' ALP-030 24'-35'		37 ⁽²⁾	38 ⁽²⁾	39 ⁽²⁾	40 ⁽²⁾	41 ⁽²⁾	42 ⁽²⁾	43 ⁽²⁾	(4)44 ⁽²⁾	45		
ALP-030N 24'-35'		46 ⁽²⁾	47 ⁽²⁾	48 ⁽²⁾	49 ⁽²⁾	50 ⁽²⁾	51 ⁽²⁾	52 ⁽²⁾	(4)53 ⁽²⁾	54		
PEL3 24' ALP-300 24'		55	56	57	58	59	60	61	62	(4)63		
PEL3 28' - 35' ALP-300 28"-35'		64	65	66	67	68	69	70	71	(4)72		
FEL3 28' - 35' ALP-F-430 28'-39'		73	74	75	76	77	78	79	(4)80	81		
Duo Safety 2 Section												
Y.G.E.-2 16'-35'		82 ⁽²⁾	83 ⁽²⁾	84 ⁽²⁾	85 ⁽²⁾	86 ⁽²⁾	87 ⁽²⁾	88 ⁽²⁾	89 ⁽²⁾	90 ⁽²⁾		
900 20'-24'		91	92	93	94	95	96	97	98 ⁽²⁾	99 ⁽²⁾		
1200 28'-35'		100 ⁽²⁾	101 ⁽²⁾	102 ⁽²⁾	103 ⁽²⁾	104 ⁽²⁾	105 ⁽²⁾	106 ⁽²⁾	107 ⁽²⁾	108 ⁽²⁾		
500-C 14'-24'		109 ⁽²⁾	110 ⁽²⁾	111 ⁽²⁾	112 ⁽²⁾	113 ⁽²⁾	114 ⁽²⁾	115 ⁽²⁾	116 ⁽²⁾ ₍₃₎	117 ⁽²⁾ ₍₃₎		
500-C 28'-35'		118 ⁽²⁾	119 ⁽²⁾ ₍₃₎	120 ⁽²⁾	121 ⁽²⁾ ₍₃₎	122 ⁽²⁾	123 ⁽²⁾	124 ⁽²⁾	125 ⁽²⁾	(4)126 ⁽²⁾ ₍₃₎		
Duo Safety 3 Section												
Y.G.E.-3 28'-35'		127 ⁽²⁾	(4)128 ⁽²⁾	(4)129 ⁽²⁾	(4)130 ⁽²⁾	131 ⁽²⁾	(4)132 ⁽²⁾	(4)133 ⁽²⁾	134	135		
925 22'-26'		136	137	138	139	140	141	142	143	(4)144		
1225 28'-35'		145	146	147	148	149	150	151	(4)152	153		
525C 28'-35'		(4)154 ⁽²⁾	155	156	(4)157 ⁽²⁾	(4)158 ⁽²⁾	(4)159 ⁽²⁾	160	161	162		

**NO LADDERS WITH POLES AND NO LADDERS OVER 35' (UNLESS SPECIAL ORDER WITH APPROVAL)
WEIGHT OF LADDERS AND/OR HARD SLEEVE MAY NOT EXCEED 300 POUNDS**

(2) USE 27" LONG CHANNEL AND 3097-250-000 SPACER SET UNDER BASE CASTING
(3) EXTENSION LADDER WEIGHT RESTS ON ROOF LADDER
(4) USE 1" SPACER (3097-105-136) BETWEEN LADDER MOUNT CASTING AND CHANNEL

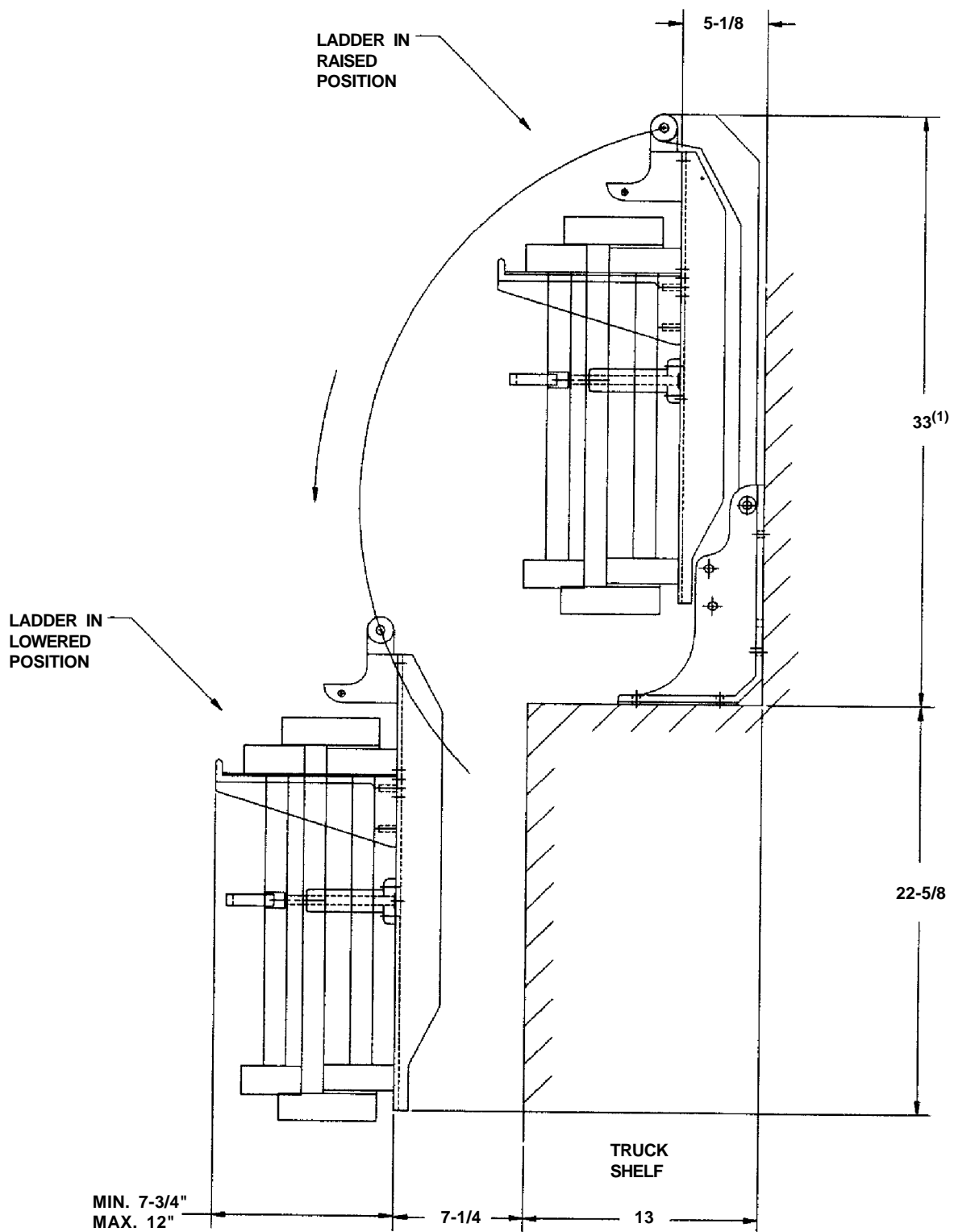


FIGURE 5. SIDE VIEW MODEL LAS-_____

⁽¹⁾ADD 1-1/2" FOR COMBINATION NUMBERS REQUIRING SET OF 4 SPACER BLOCKS (SEE CHART 3)

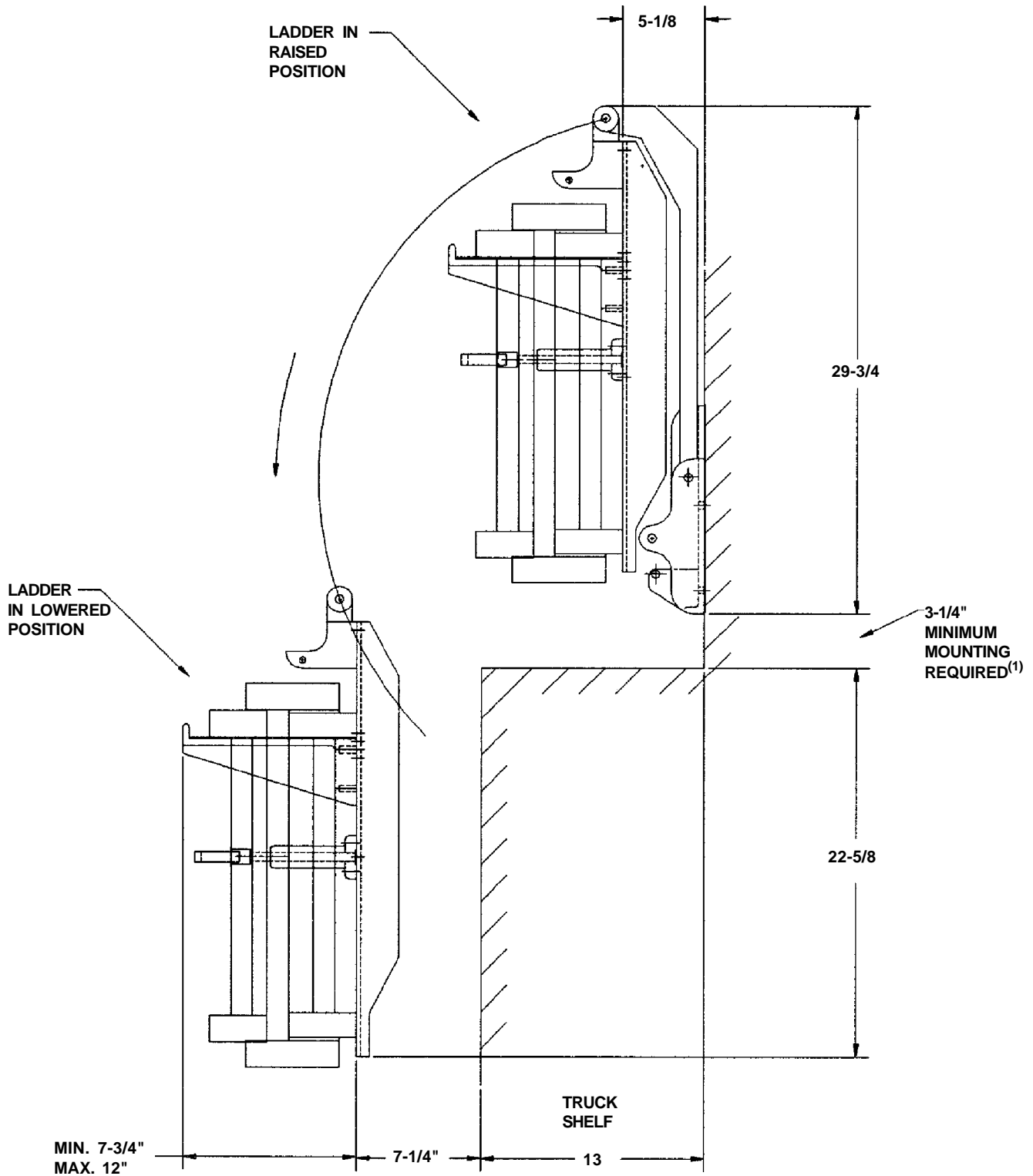


FIGURE 6. SIDE VIEW MODEL LAS-BHM-_____

⁽¹⁾ADD 1-1/2" FOR COMBINATION NUMBERS REQUIRING 27" LONG CHANNELS TO ALLOW FOR EXTRA WIDTH OF THESE LADDERS (SEE CHART 3)

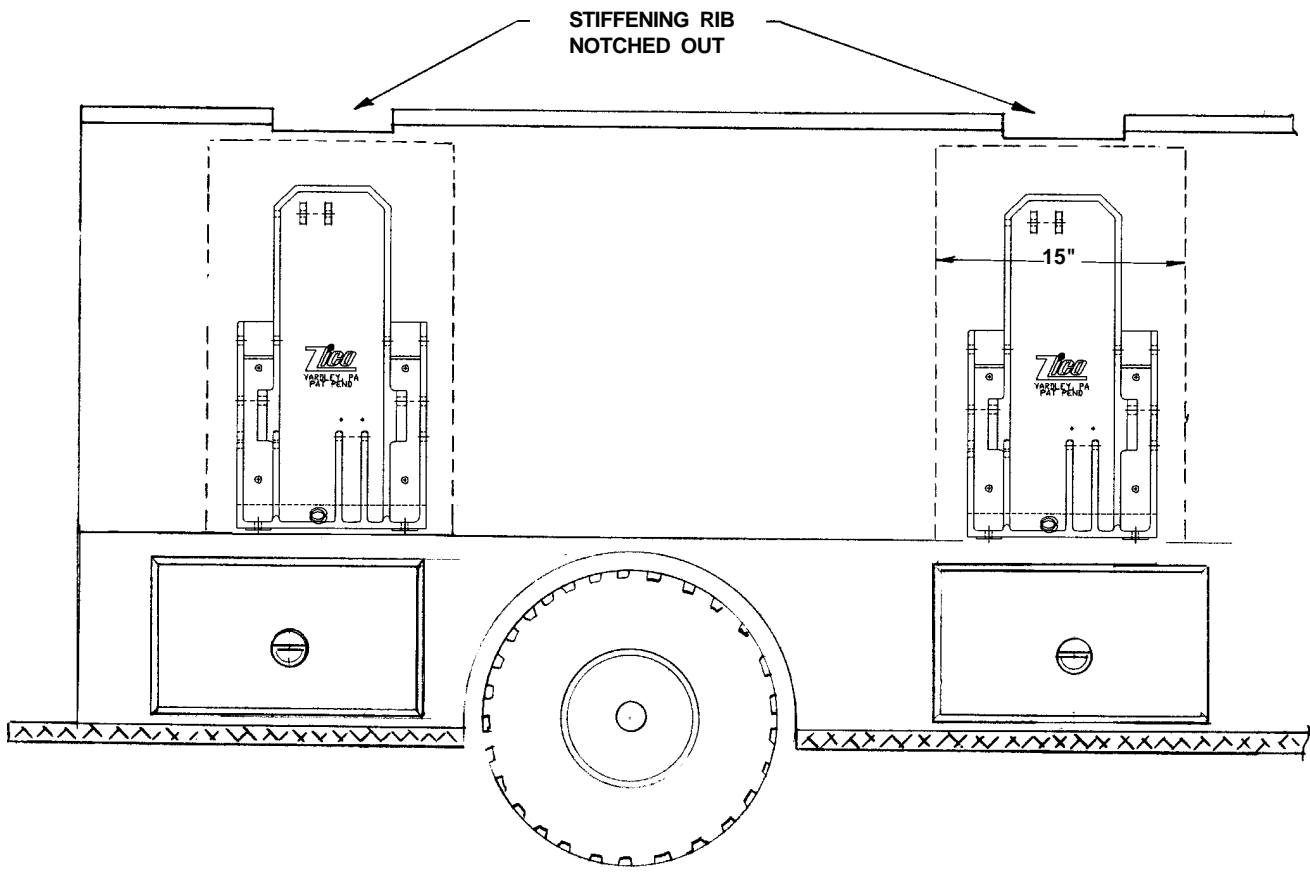
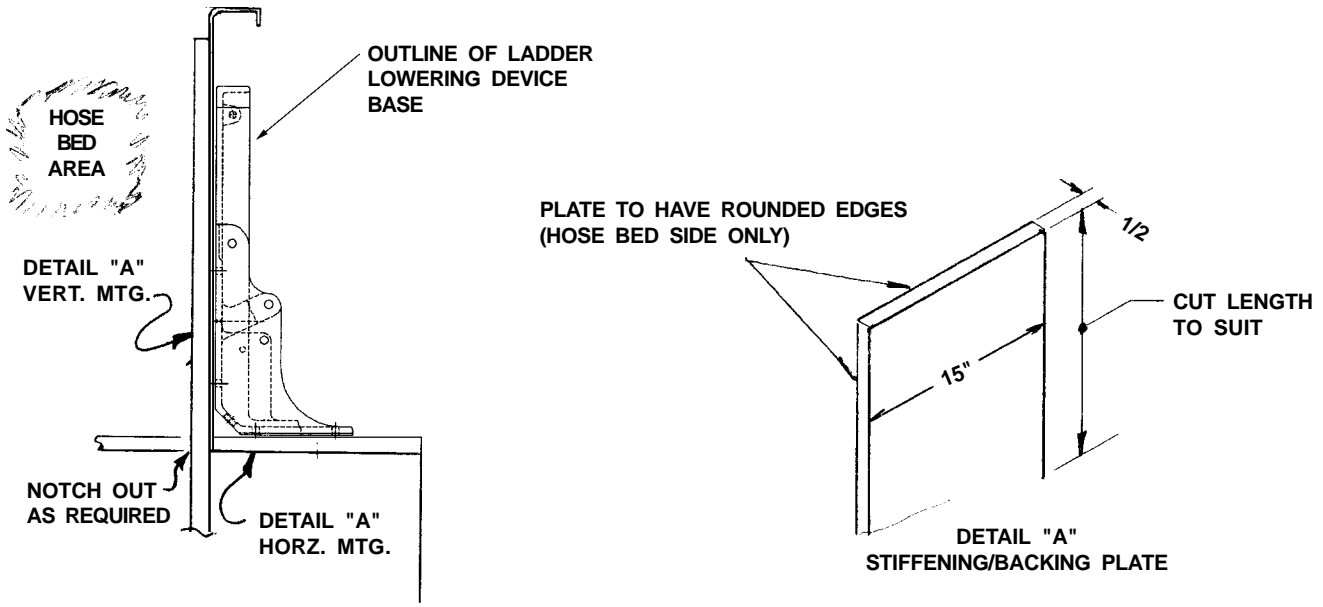
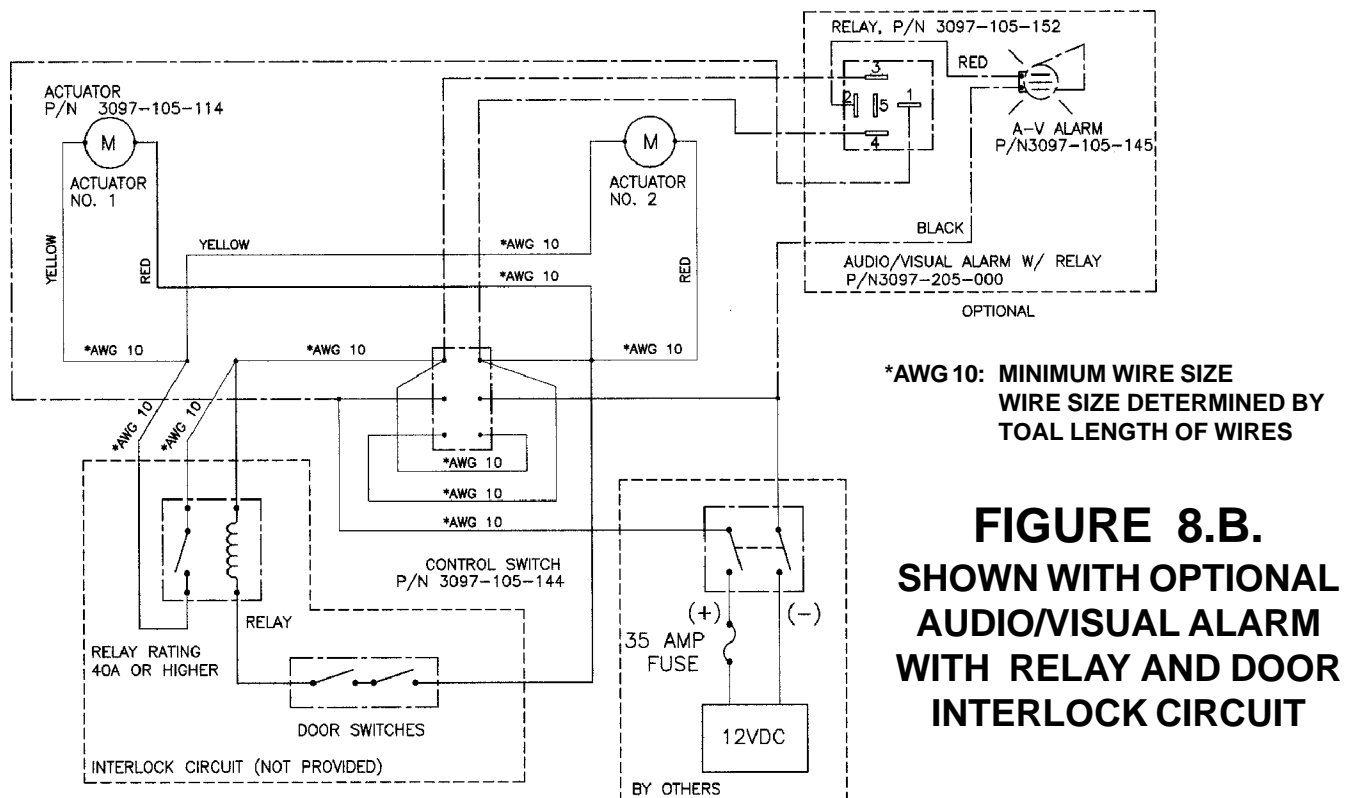
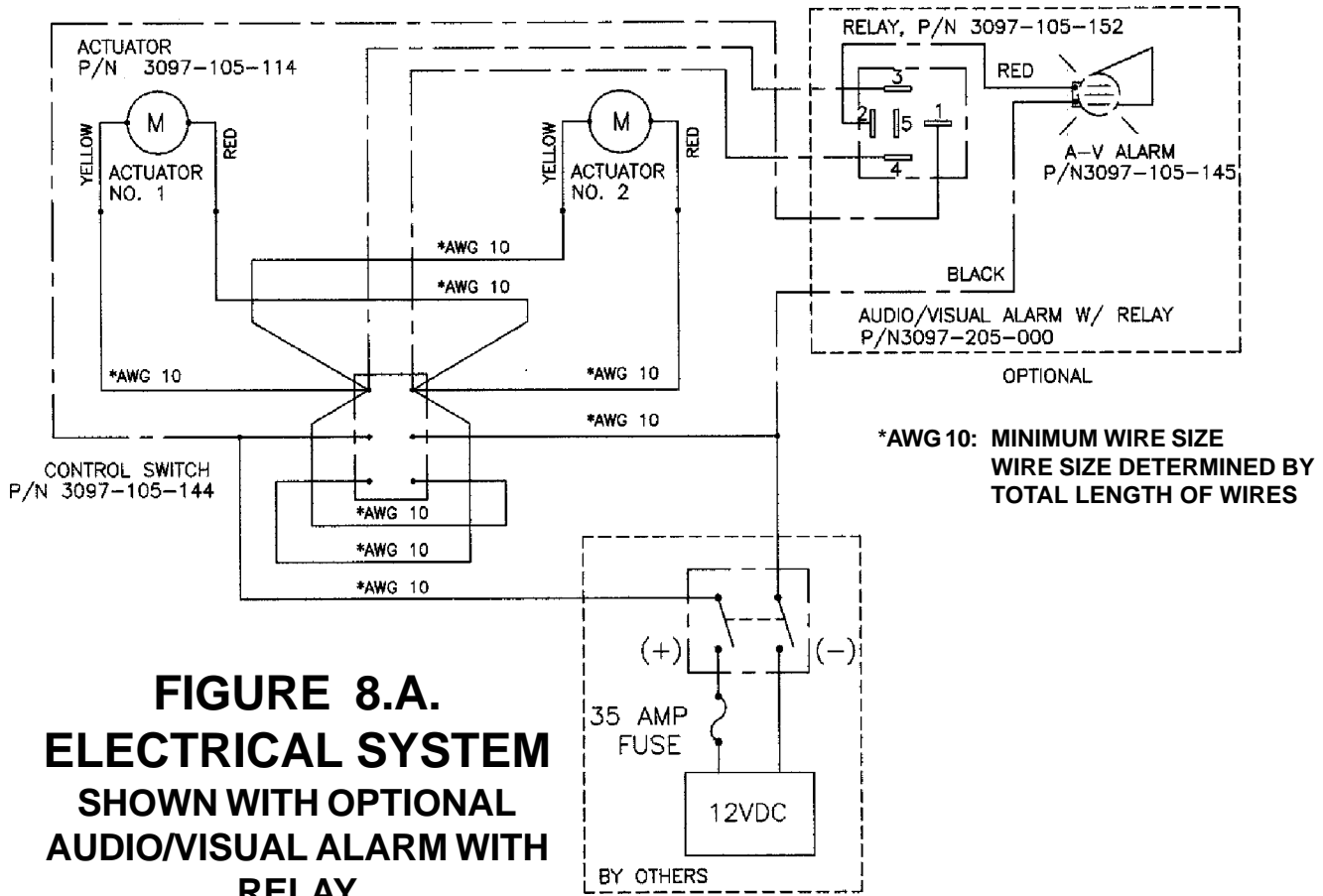
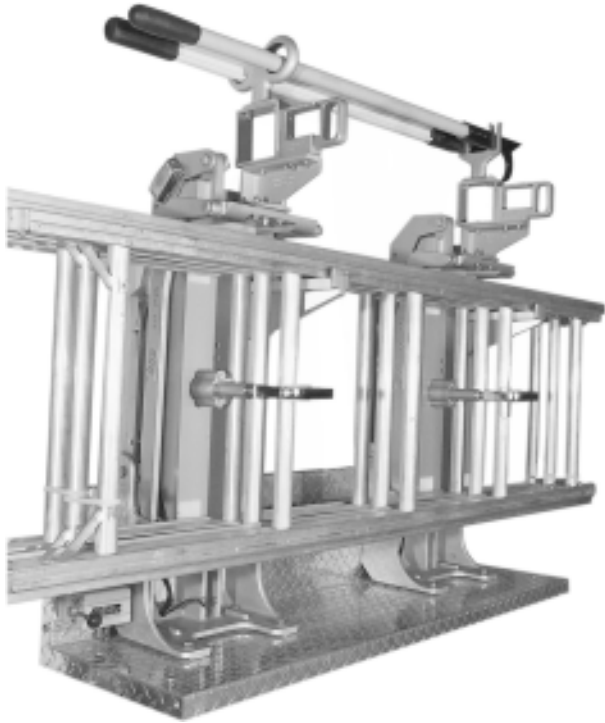


FIGURE 7. COMMON INSTALLATION USING STIFFENING/BACKING PLATE





**FIGURE 9.
FRONT VIEW OF
LAS SYSTEM**

**NOTE EQUAL NUMBER OF
RUNGS TO LEFT (A) AND
RIGHT (B) OF DEVICE**

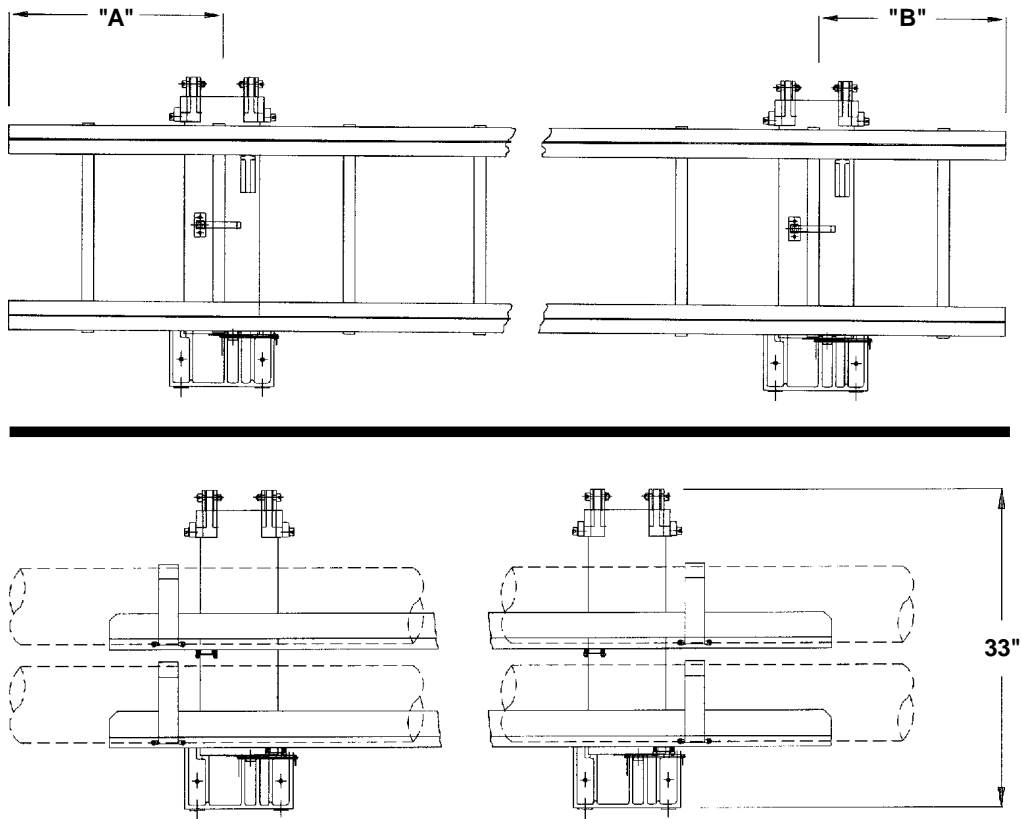


FIGURE 10. FRONTAL VIEW OF HSS SYSTEM

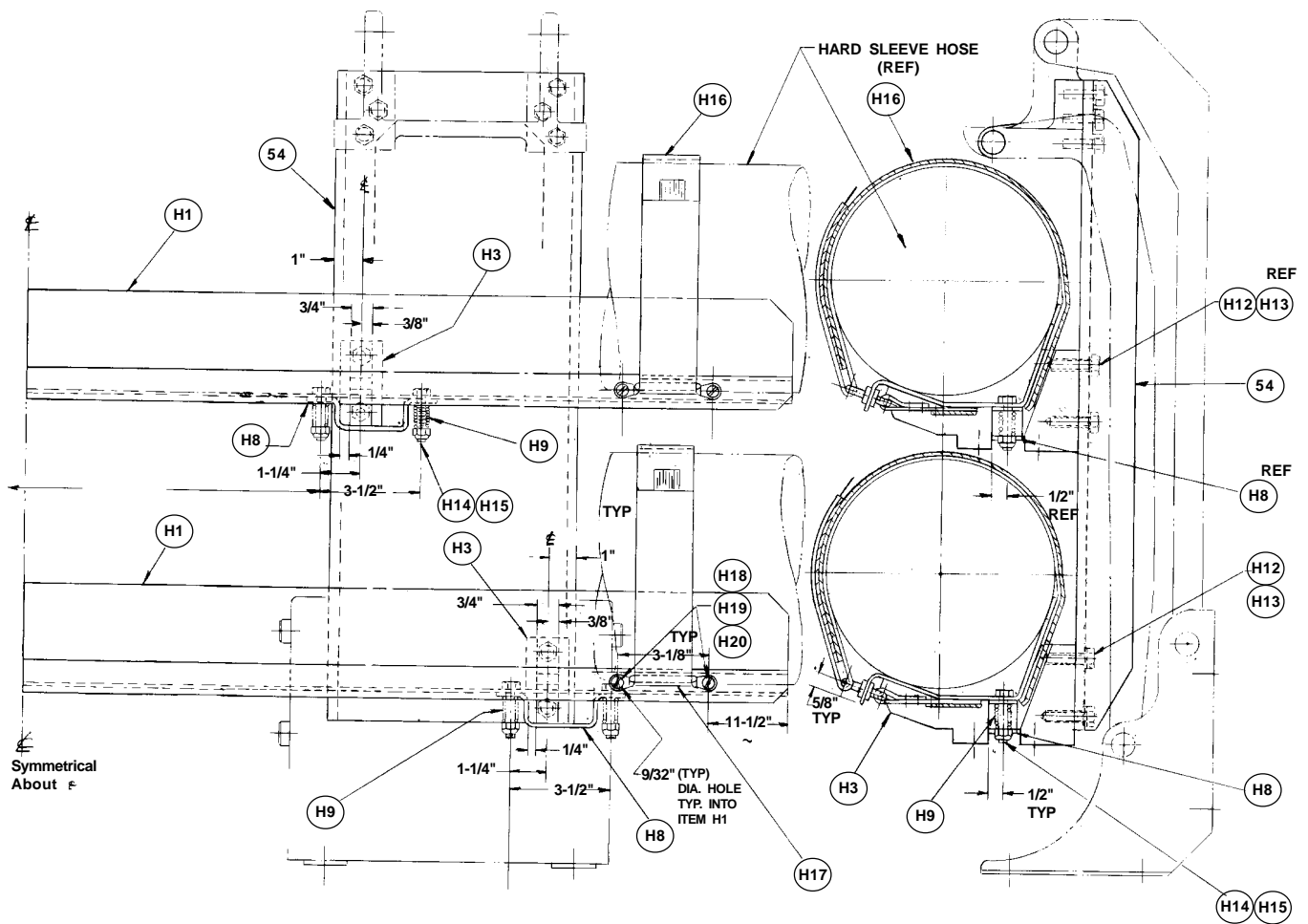
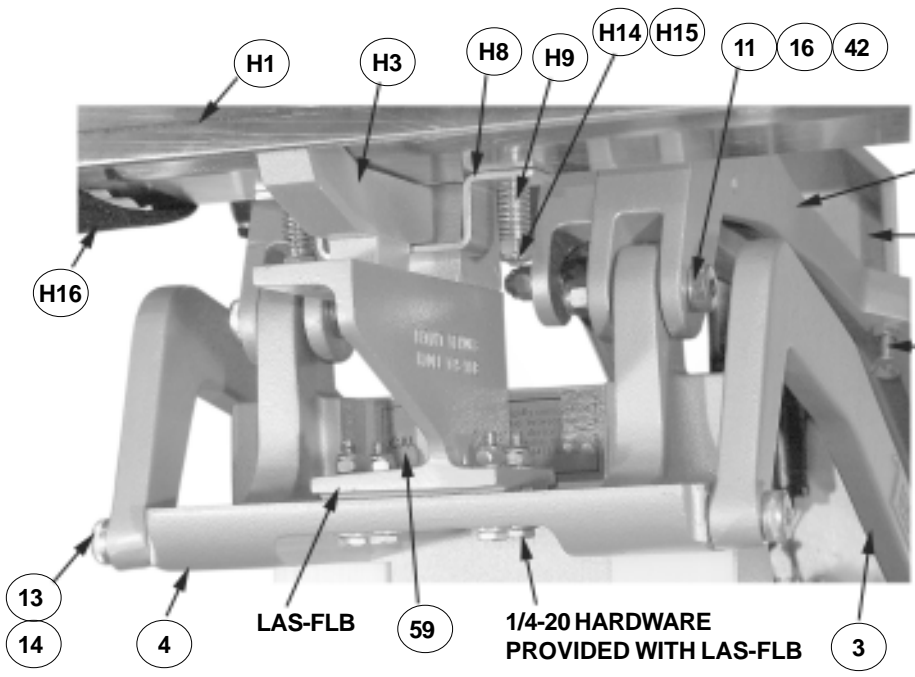


FIGURE 11. MODEL HSS-___ HARD SLEEVE SYSTEM

CHART 4. MODEL HSS-___ PARTS LIST

ITEM	PART NUMBER	DESCRIPTION	HSS-200	HSS-CWT-210
H1	3097-155-101	Hose Tray, 112" Long	-	2
H3	3097-150-103	Hose Tray Support Casting	2	2
54	3097-105-154	Channel Support 8" W x 25-1/4" L	1	1
H8	3097-150-108	Hose Tray Retainer	2	2
H9	3090-000-120	Compression Spring	4	4
H12	9010-103722	Hex Head Bolt, 3/8-16 x 1-3/8"	4	4
H13	9014-203700	Lock Washer, 3/8 I.D.	4	4
H14	9110-103124	Hex Head Bolt, 5/16-18 x 1-1/2"	4	4
H15	9113-103100	Hex Head Lock Nut, 5/16-18	4	4
H16	3099-738-000	Utility Mounting Strap # UMVS-1625-10	-	2
H17	3099-000-113	Footman's Loop, 2" # CPFL000003	-	4
H18	9010-232512	Round Head Screw, 1/4-20 x 3/4"	-	4
H19	9014-205500	Lock Washer, 1/4" I.D.	-	4
H20	9012-102500	Hex Head Nut, 1/4-20	-	4

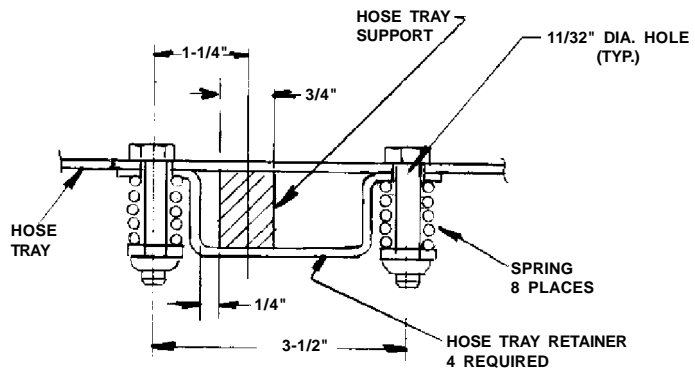
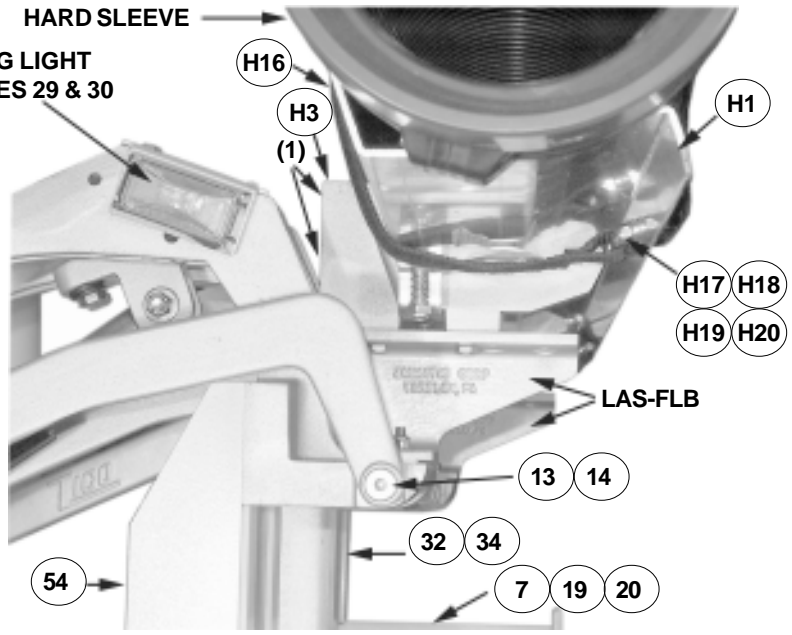


**FIGURE 12.
HARD SLEEVE
TRAY
MOUNTED
ON LAS-____
SYSTEM.
REQUIRES
LAS-FLB SET**

(1) H12 AND H13 WOULD BOLT THROUGH CHANNEL (54) AND INTO HOSE RAY SUPPORT CASTING (H3) ON THE HSS-____ SYSTEM.

HSS-TMC INCLUDES: H3, H12, H13, H14 AND H15

HSS-TMH INCLUDES: H8, H9, H14, H15, H16, H17, H18, H19 AND H20



DETAIL "A" SCALE 1/2

**FIGURE 13.
HARD SLEEVE
SYSTEM LOCATION AND
DRILLING INSTRUCTIONS**

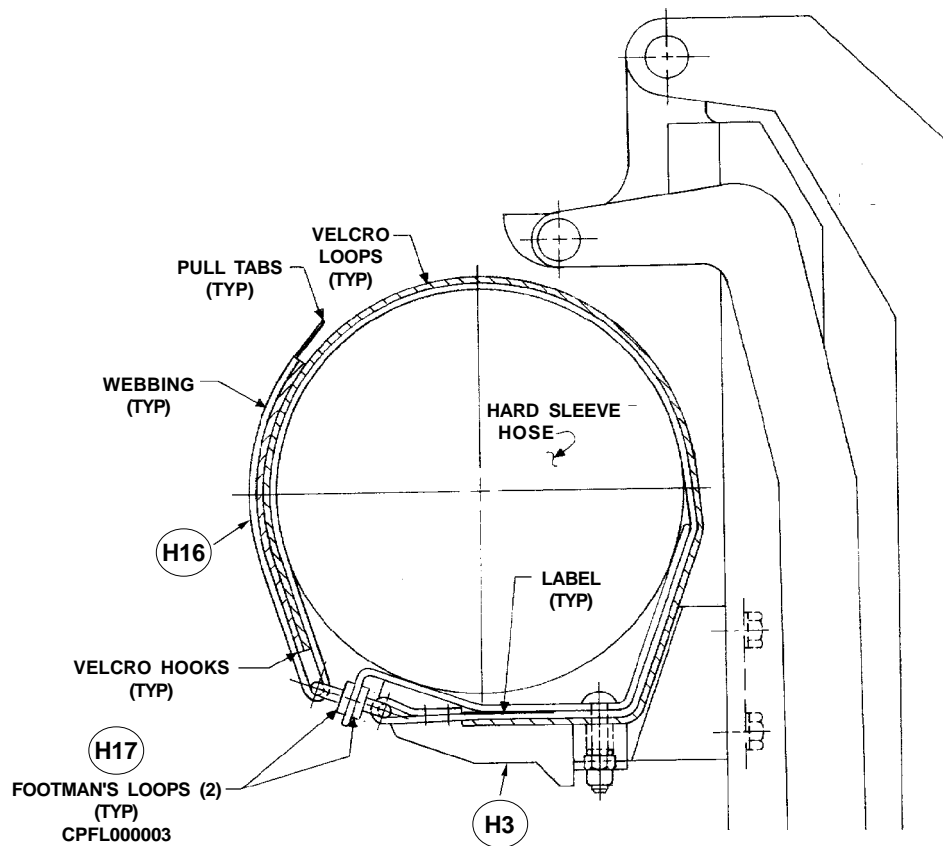


FIGURE 14. QUIC-STRAP SYSTEM TO RETAIN HARD SLEEVE

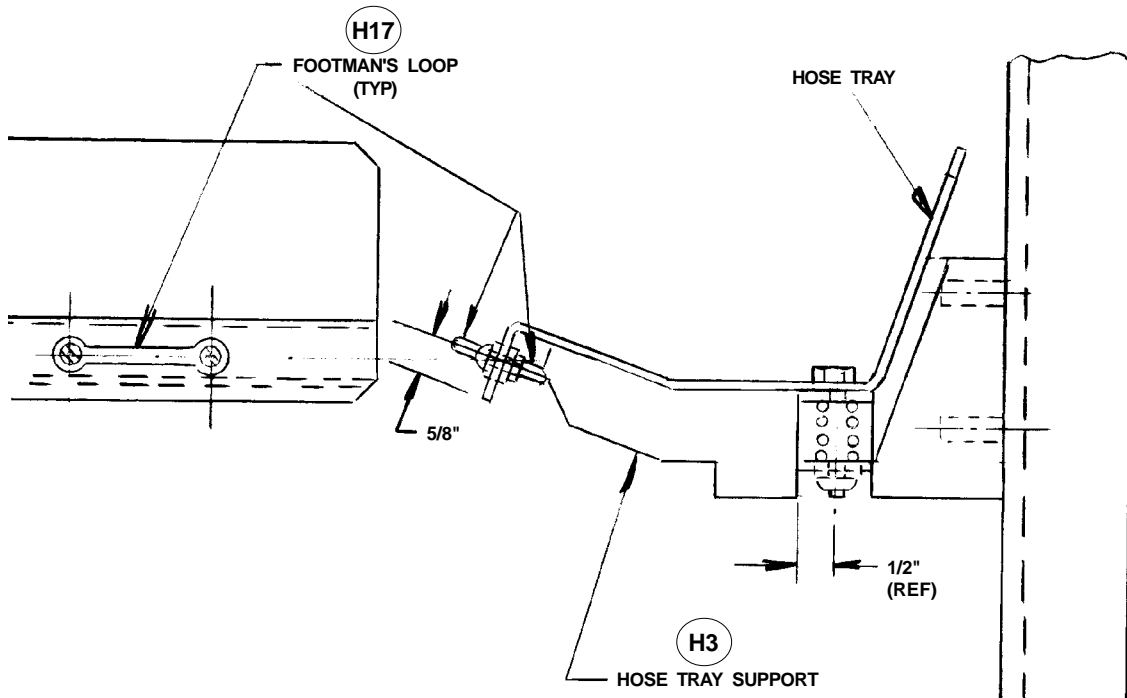


FIGURE 15. HOSE TRAY SUPPORT WITH HOSE TRAY

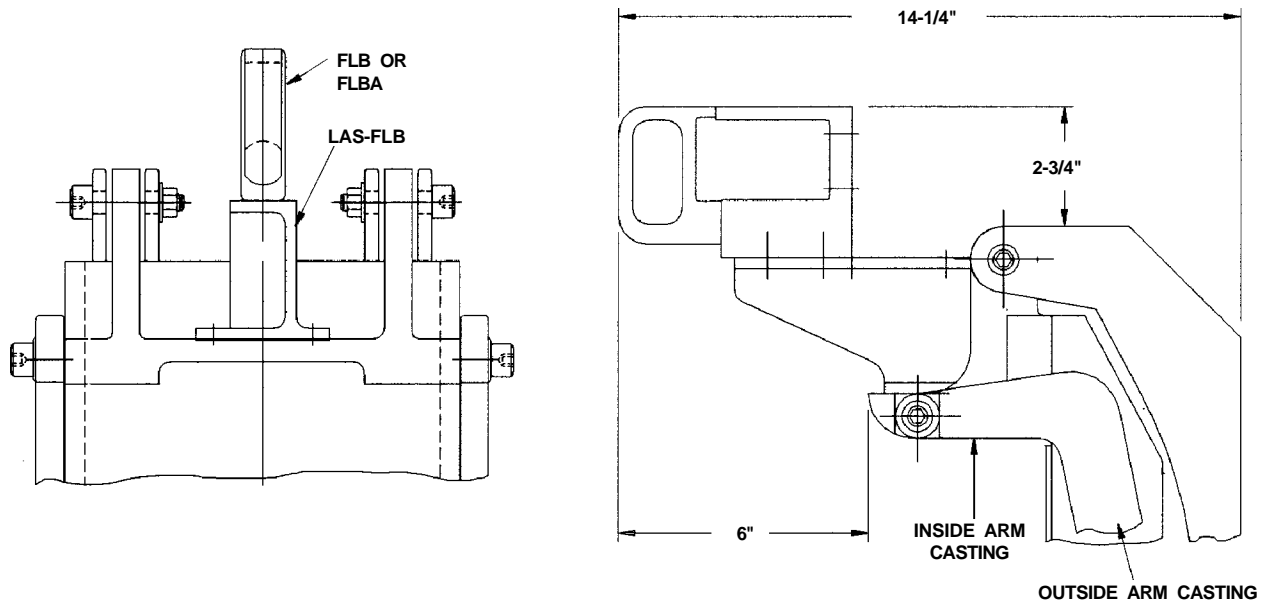


FIGURE 16. MODEL LAS-FLB CASTINGS ATTACHED TO PIVOT SUPPORT CASTING (3097-105-104) WITH MODEL FLB OR FLBA FOLDING LADDER BRACKET CASTING FOR FOLDING ATTIC LADDER

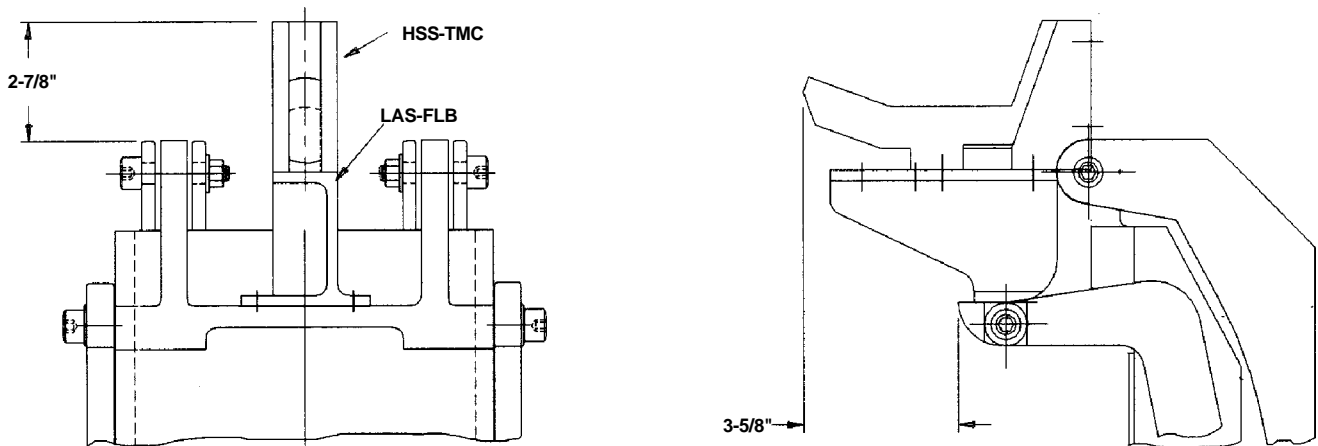
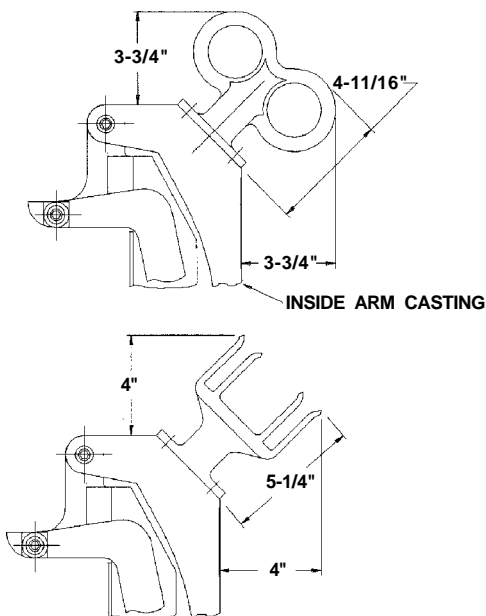
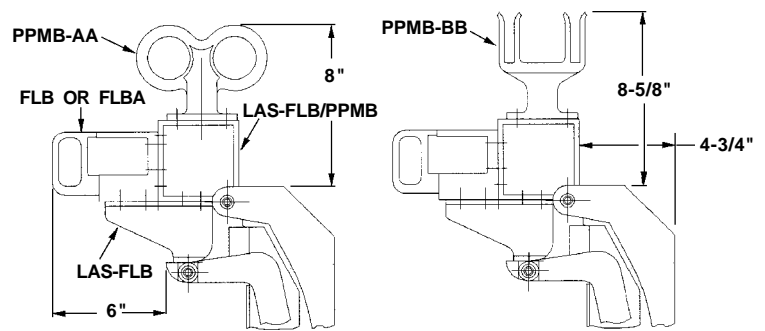


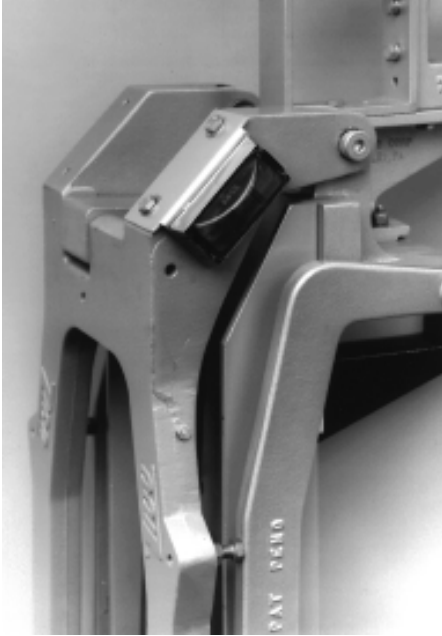
FIGURE 17. MODEL LAS-FLB ATTACHED TO PIVOT SUPPORT CASTING (3097-105-104) WITH MODEL HSS-TMC TRAY MOUNT CASTING FOR MOUNTING OF HARD SLEEVE



**FIGURE 18.
MODEL LAS-FLB/PPMB
EXTRUSION ADDED TO
SUPPORT PPMB-AA
(DOUBLE RING) OR
PPMB-BB (DOUBLE FORK)
PIKE POLE MOUNTING
BRACKET**



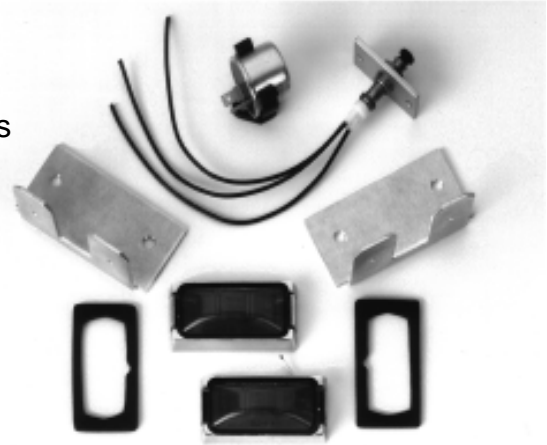
**FIGURE 19.
MODEL PPMB-AA (DOUBLE RING)
OR PPMB-BB (DOUBLE FORK)
PIKE POLE MOUNTING BRACKETS
MAY BE ATTACHED DIRECTLY TO THE
INSIDE ARM CASTING (3097-105-102)**



NFPA 1901-96 Standard requires flashing lights be provided, facing front and rear of apparatus. Lights must continue to flash while the device is out of the stored position.

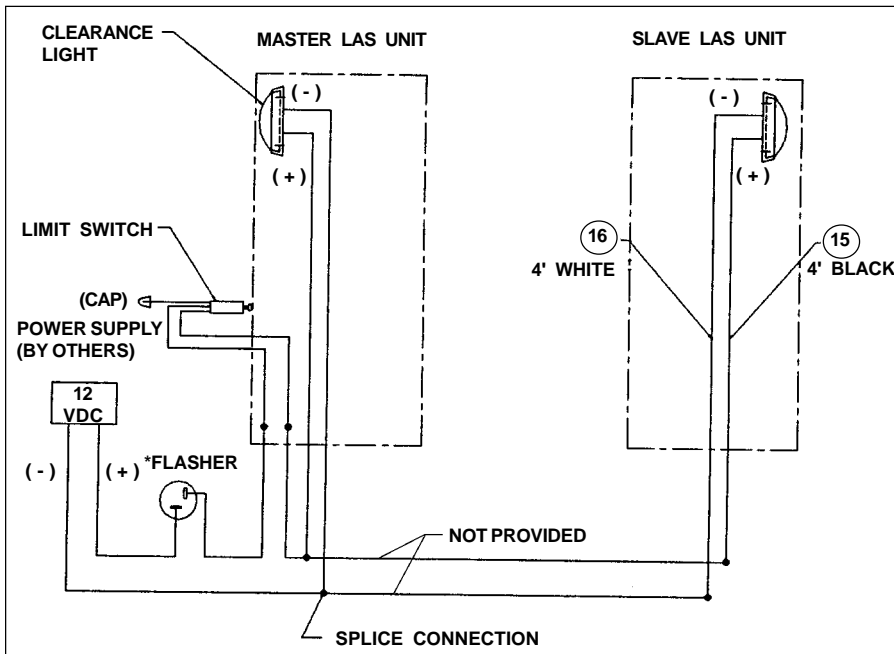
Beginning January 1, 1997, all systems are provided with flashing lights. The audio/visual alarm will continue to be offered as an option (see Section 8000 for the audio/visual alarm).

Drilled and tapped holes will be provided on QUIC-LIFT Systems shipped after January 1, 1997, to mount the light kits.



LIGHT KIT COMPONENTS

MODEL NUMBER	PART NUMBER	DESCRIPTION	WT./SET IN LBS.
LAS-FLK	3097-270-000	Flashing Light Kit	1.0



Wiring System:

1. One white wire 4' long (item 16) and one black wire 4' long (item 15) are provided for each light (item 1).
2. In-line splices (item 12) are provided. Seventh splice to be connected to third wire in the limit switch (item 3). This wire may be used for indicator light in the cab.
3. Flasher (item 5) should be mounted in a weather-proof location and mounted in the clip (item 17) provided.

**FIGURE 20. FLASHING LIGHT KIT
MODEL LAS-FLK**

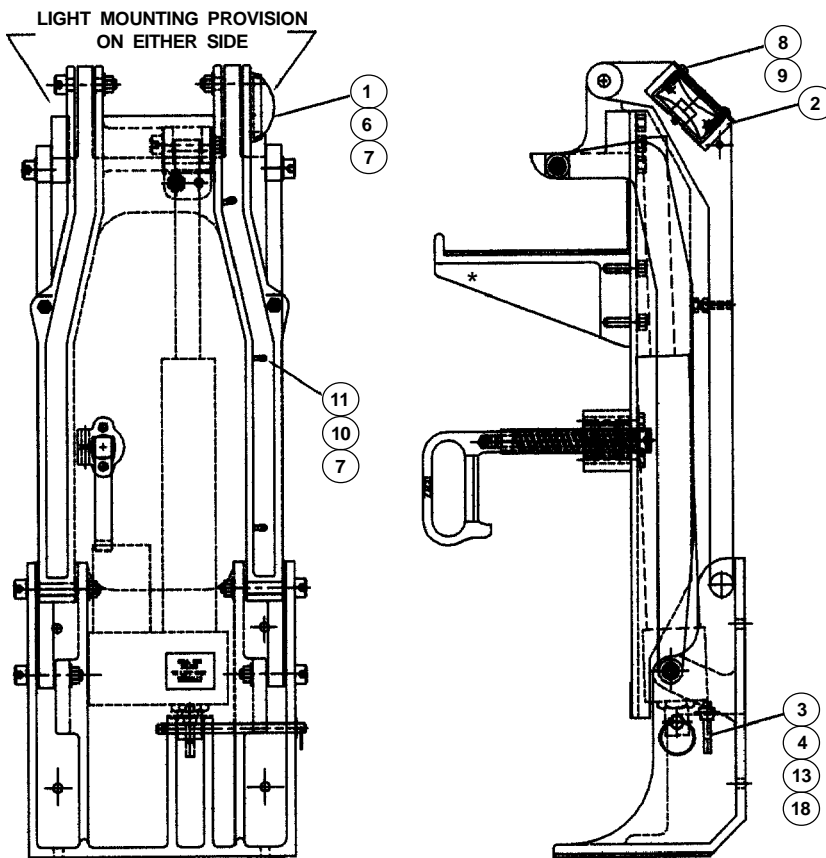
ITEM NO.	PART NUMBER	DESCRIPTION	QTY.
1	3097-270-101	Clearance Light	2
2	3097-270-103	Bracket, Light Mount	2
3	3097-270-105	Switch, Limit	1
4	3097-270-107	Plate, Limit Switch	1
5	3097-270-109	Flasher	1
6	9010-221108	Screw, 4-40 x 1/2 Pan Hd Phillips	4
7	9012-131100	Flex Loc Hex Nut 4-40, SZP	10
8	9010-102510	Screw, HH 1/4-20 x 5/8 M/S SZP	4
9	9014-202500	Lockwasher, 1/4 Nom.	4
10	9010-221112	Screw, 4-40 x 3/4 Pan Hd Phillips	6
11	3097-270-111	Cable Tie	6
12	3097-270-113	In Line Splice	7
13	9020-101505	#7 x 5/16 Drive Screw SZP	2
15	3097-270-119	16 Ga Lead Wire - Black SFF U/13070	2-4 Ft
16	3097-270-120	16 Ga Lead Wire - White SFF U/13070	2-4 Ft
17	3075-175-105	Delrin Tool Clip	1
18	3097-270-122	Butt Connector (use with Item 5)	2

CHART 5. PARTS LISTING FOR MODEL LAS-FLK

Please make sure all parts are accounted for prior to beginning installation.

The limit switch plate (item 4) has been pre-mounted onto one of the base castings using two #7 drive screws (item 13).

Holes will need to be drilled, in one of the base castings and in the inner arm castings, if the LAS unit was shipped prior to January 1, 1997.



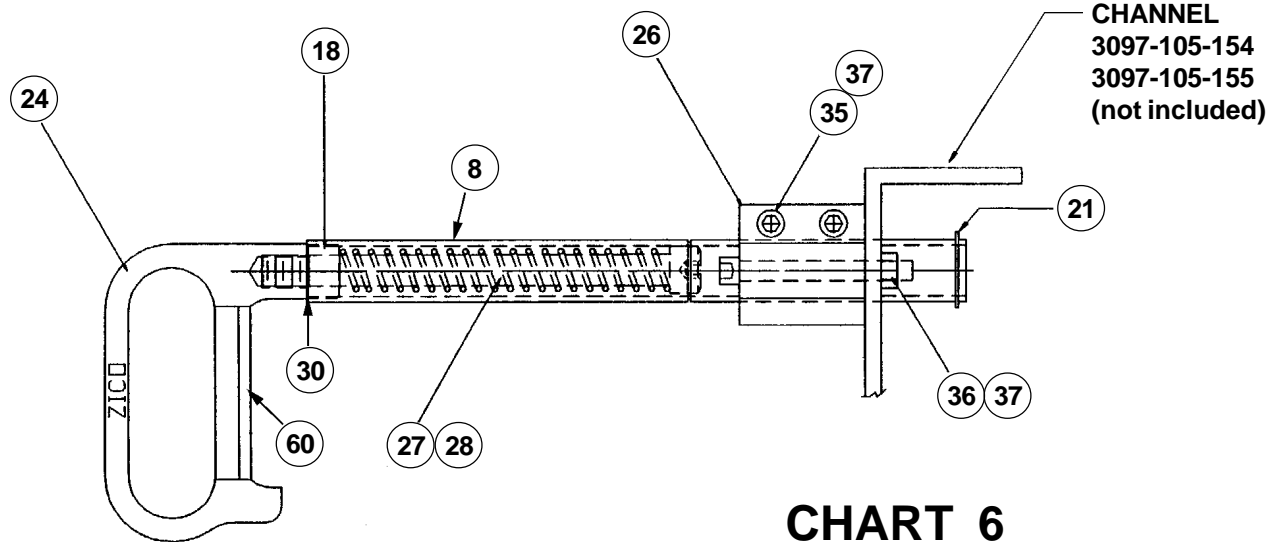
Lights are to be mounted on the outboard side on each set of LAS units.

Limit switch (item 3) makes contact with the electric actuator housing to shut off the lights.

*Reflective tape is now attached to each ladder mount casting in compliance with NFPA 1901-96.

**FIGURE 21. FLASHING LIGHT KIT
MODEL LAS-FLK**

Effective January 18, 1999 we began using a new handle assembly, on all QUIC-LIFT Ladder Access Systems, with model numbers beginning with LAS and LAS-BHM. Item numbers 8, 30, and 31, from the parts list for LAS and LAS-BHM, have been deleted. Length has changed from 7" to 6-1/2" for item 27. Items 18, 21, 26, 35, 36, and 37 have been added.



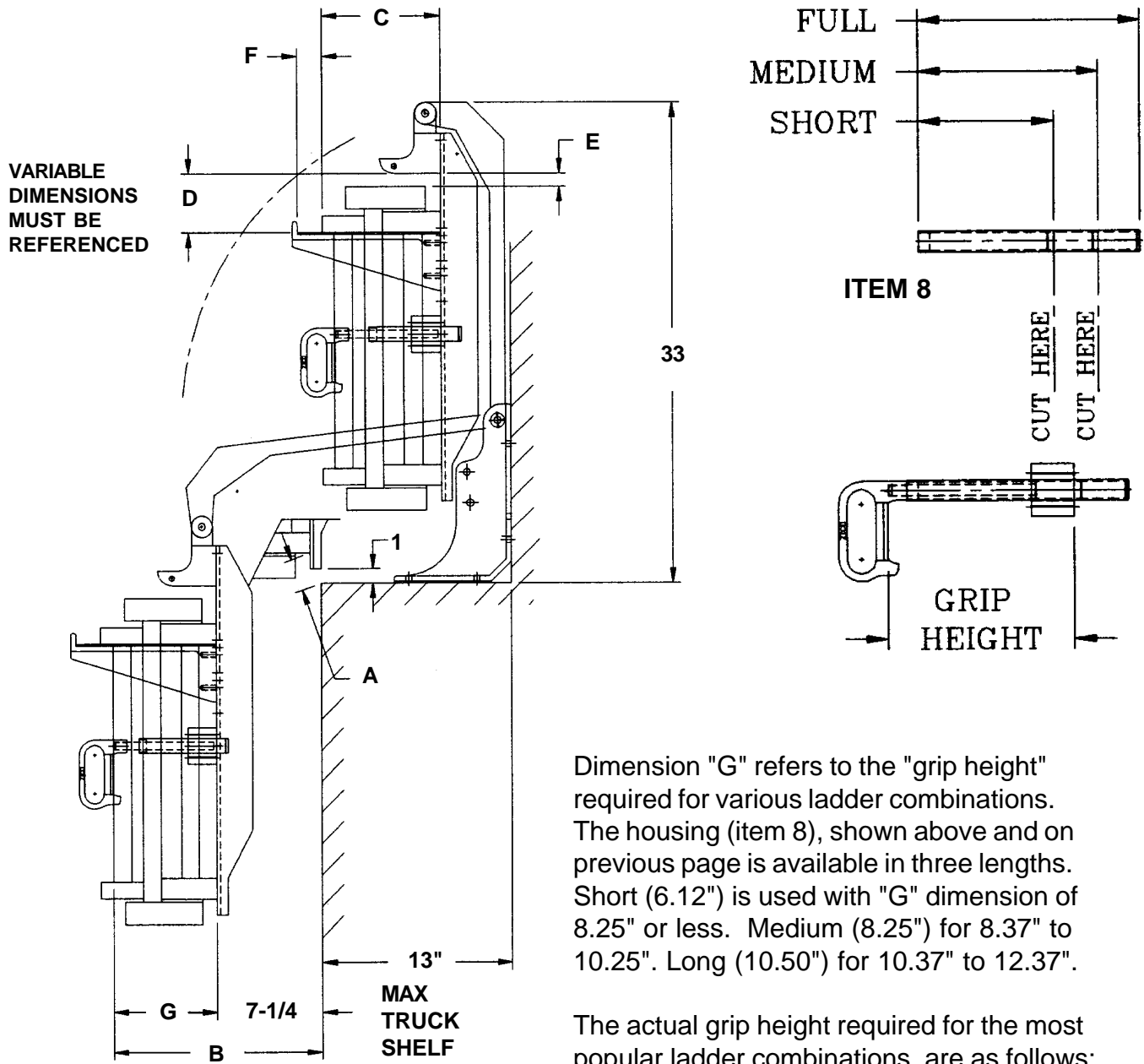
**CHART 6
PARTS LISTING FOR
LAS HANDLE ASSEMBLY**

Order 3097-105-910 to receive one complete handle assembly for LAS-775. For LAS-975 order 3097-165-910 and for LAS-1200 order 3097-145-910. Two handles are required per system.

ITEM	PARTNAME	PARTNUMBER	QTY.
8 {	Housing - For LAS-775	3097-105-125	} 1
	Housing - For LAS-975	3097-165-125	
	Housing - For LAS-1200	3097-145-125	
18	Set Screw - 7/8-14 Hollow Lock	3097-105-118	1
21	Ret. Ring, 1ø Ext. (5100-100)	3097-105-121	1
24	Handle	3097-105-109	1
26	Support, Retainer Handle	3097-105-126	1
27	Screw 1/2-13 x 6 1/2 Socket Hd	9010-3350104	1
28	Spring	3097-105-113	1
30	Nylon Washer, 1/2 ID x 3/4 OD	3097-105-130	1
35	Screw, 5/16-18 x 2 Socket Hd	9010-333132	2
36	Screw, 5/16-18 x 2 3/4 Socket Hd.	9110-333144	2
37	Hex Nut, 5/16-18 Self Lock	9013-133100	4
60	Wear Strip	3097-105-160	1

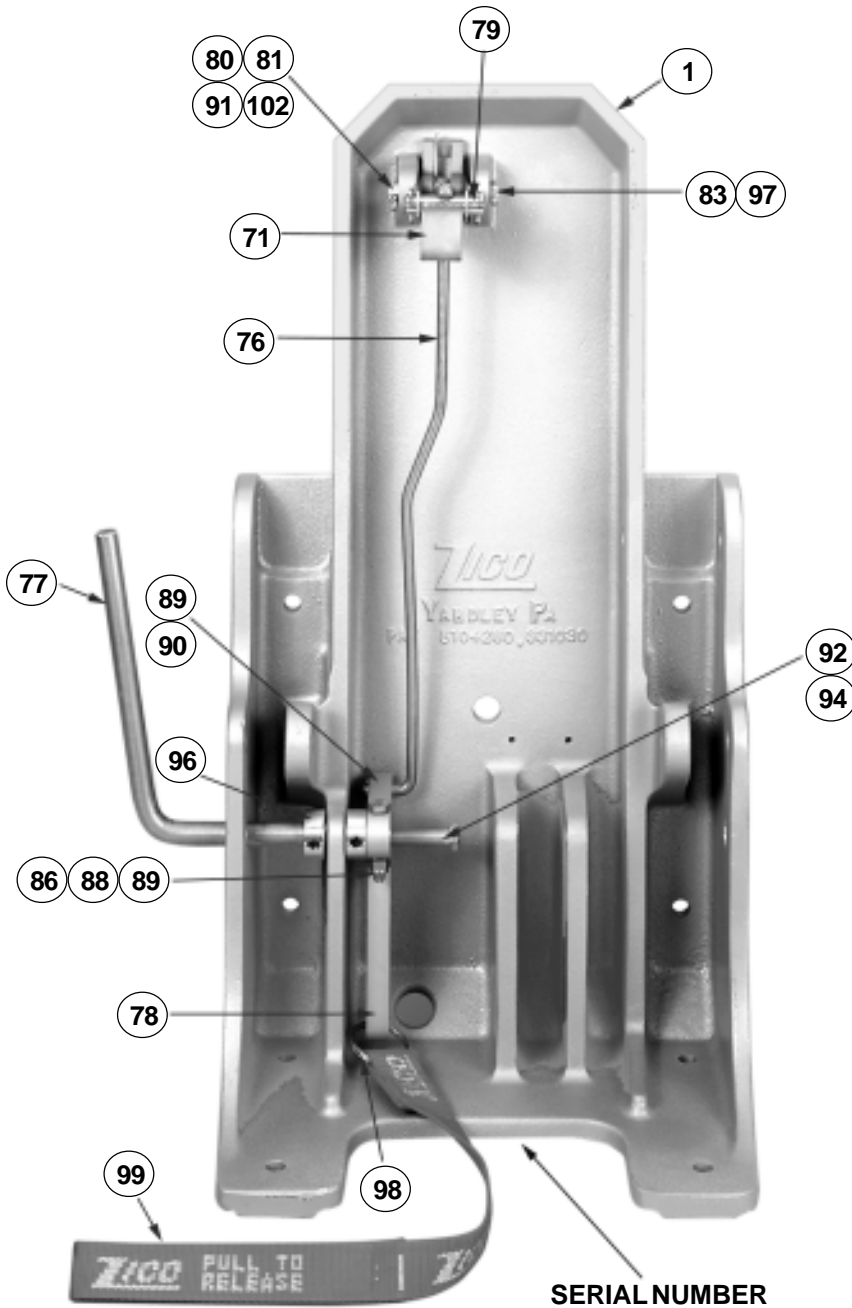
For LAS and LAS-BHM Systems purchased prior to January 18, 1999 the channel support (item 54 or 55) will have to be reamed out to use the new handle assembly. The hole must be opened up from .875" to 1.031".

**FIGURE 22.
HANDLE ASSEMBLY FOR LAS SYSTEMS**



<u>COMB. NO.</u>	<u>GRIP HEIGHT</u>	<u>LENGTH TUBE</u>
10	5.00"	Short
55	7.25"	Medium
64	8.00"	Medium
95	5.50"	Short
149	8.50"	Medium

FIGURE 23.
HANDLE ASSEMBLY FOR LAS SYSTEMS



QUIC-LIFT™ Ladder Access Systems are now available with either a manual or electric locking system. This page covers the manual system.

The Model LAS base casting has been changed. This new style base casting became available March 23, 1998.

The base casting for the Model LAS-BHM Bulk Head Mount System has also been changed and has been in use since September 16, 1998.

If your system predates the above dates, the new base will be required in addition to the manual locking system.

The manual locking system provides a positive means of retaining the ladders. The lock must be de-activated prior to operating the electrical control. This is done by pulling outward on the strap (99) or pushing back on the handle (77).

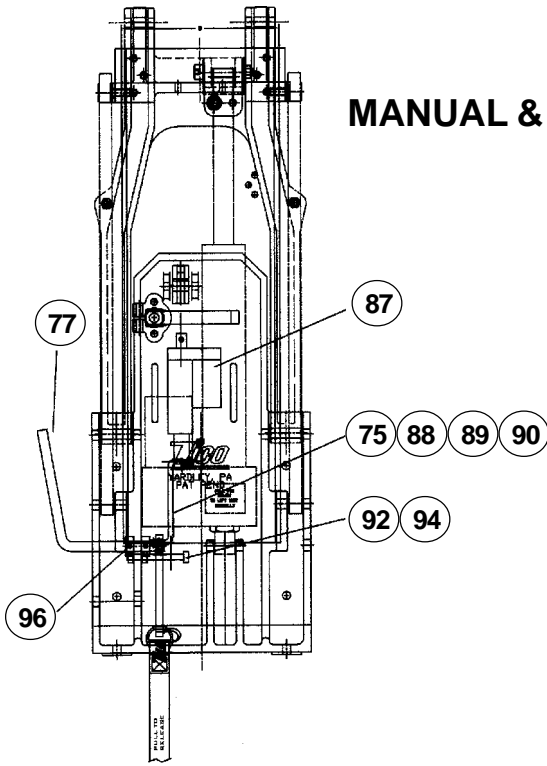
Parts list provided on pages 34 and 35.

Model LLAS-MLS shown for use with Model LAS Systems
Model LLAS-BHM-MLS is used with Model LAS-BHM Systems

FIGURE 24.
MANUAL LOCKING SYSTEM

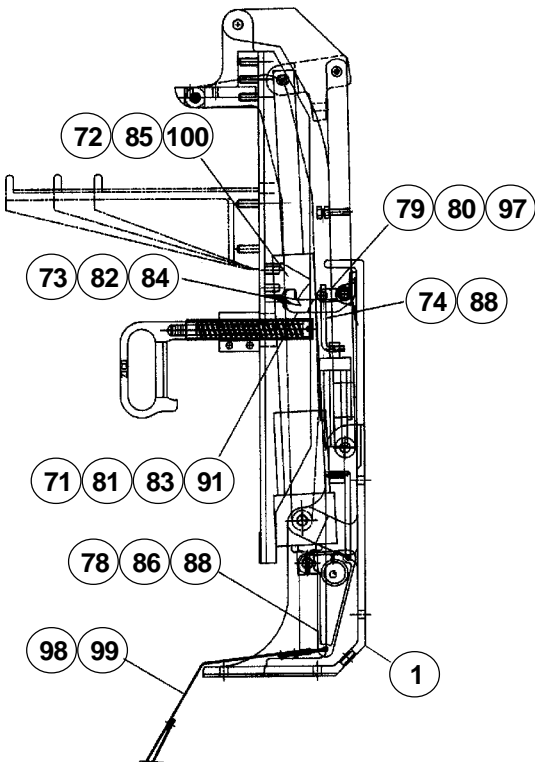
CHART 7 PARTS LISTING MANUAL & ELECTRIC LOCKING SYSTEMS

ELECTRIC
MANUAL

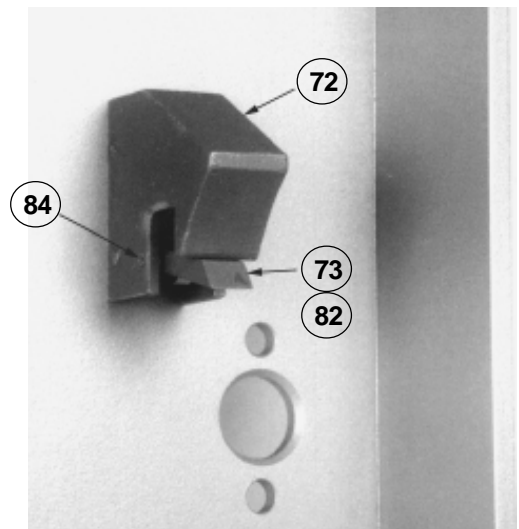


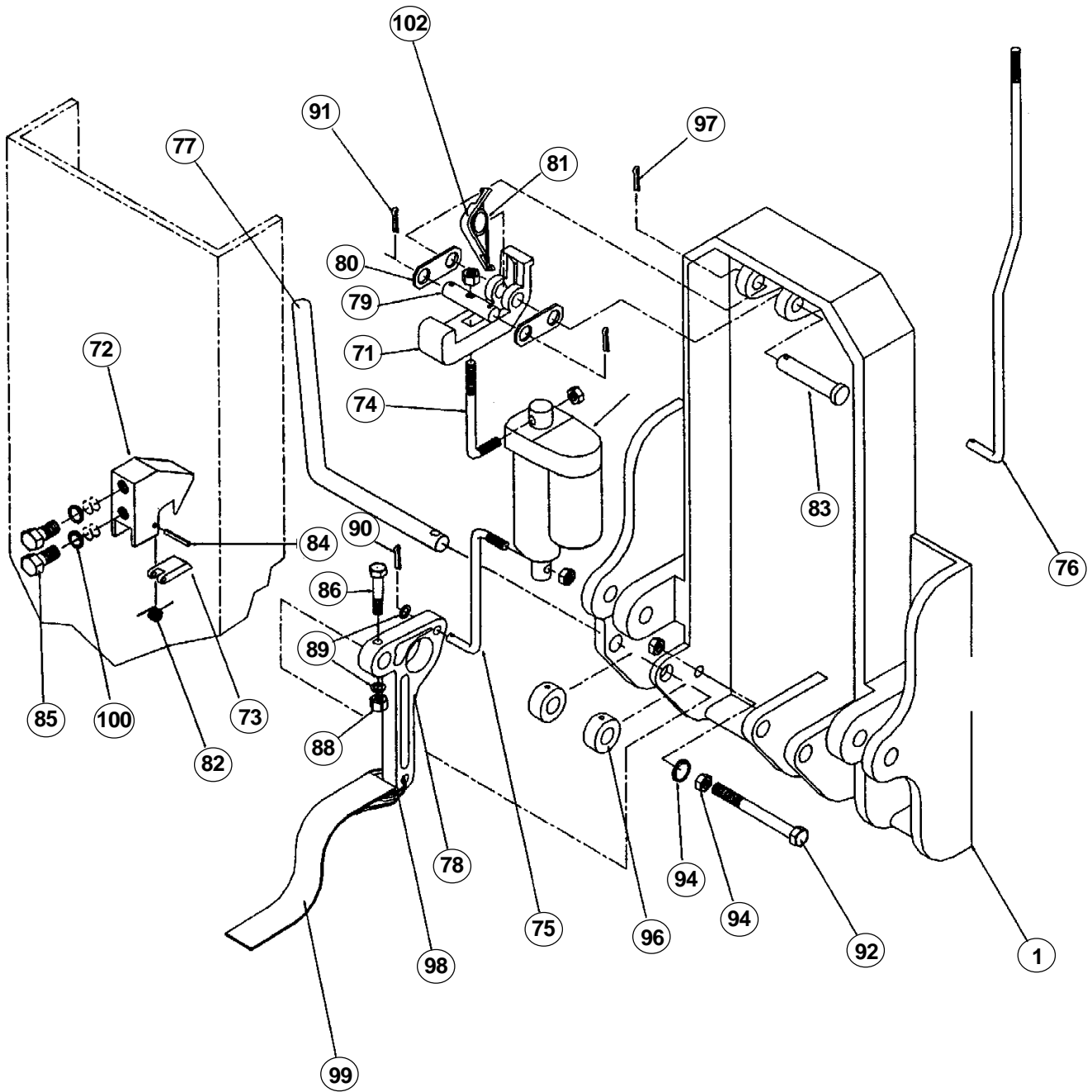
**FIGURE 25.
LOCKING SYSTEM
COMPONENTS**

ITEM NO.	PART NO.	DESCRIPTION	QTY.	QTY.
1	3097-280-101	Base casting for LAS	} 1	1
	3097-107-101	Base casting for LAS-BHM		
71	3097-280-103	Latch casting	1	1
72	3097-280-105	Hook casting	1	1
73	3097-280-107	Latch keeper casting	1	1
74	3097-285-109	Upper rod	1	
75	3097-285-111	Lower rod	1	
76	3097-280-113	Manual rod		1
77	3097-280-115	Handle	1	1
78	3097-280-117	Crank arm	1	1
79	3097-280-119	Link pin	1	1
80	3097-280-121	Link plate	2	2
81	3097-280-123	Latch spring	1	1
82	3097-280-125	Keeper spring	1	1
83	9080-004336	Clevis pin - 7/16 x 2-1/4	1	1
84	9040-101214	Spring pin - 1/8 x 7/8	1	1
85	9010-103712	3/8-16 x 3/4 HH C/S	2	2
86	9010-102522	1/4-20 x 1-3/8 HH M/S	1	1
87	3097-285-135	Electric actuator	1	
88	9013-172500	Nut, self-locking - 1/4-20	4	2
89	9014-112500	Washer, plain - 1/4 ID	4	2
90	9070-000608	Cotter pin - 1/16 x 1/2	1	1
91	9070-000912	Cotter pin - 3/32 x 3/4	2	2
92	9010-103144	Screw - 5/16-18 x 2-3/4	1	1
94	9013-103100	Nut - 5/16-18	2	2
96	3097-280-127	Shaft collar - 1/2"	2	2
97	9070-001216	Cotter pin - 1/8 x 1	1	1
98	0000-000-120	Key ring - 1"	1	1
99	3097-280-129	Strap - 1" W x 15" L	1	1
100	9014-203700	Lockwasher, split - 3/8 ID	2	2
101	3097-285-200	Control panel assembly (not shown)	1	
102	3097-280-131	Spring installation tool	1	1



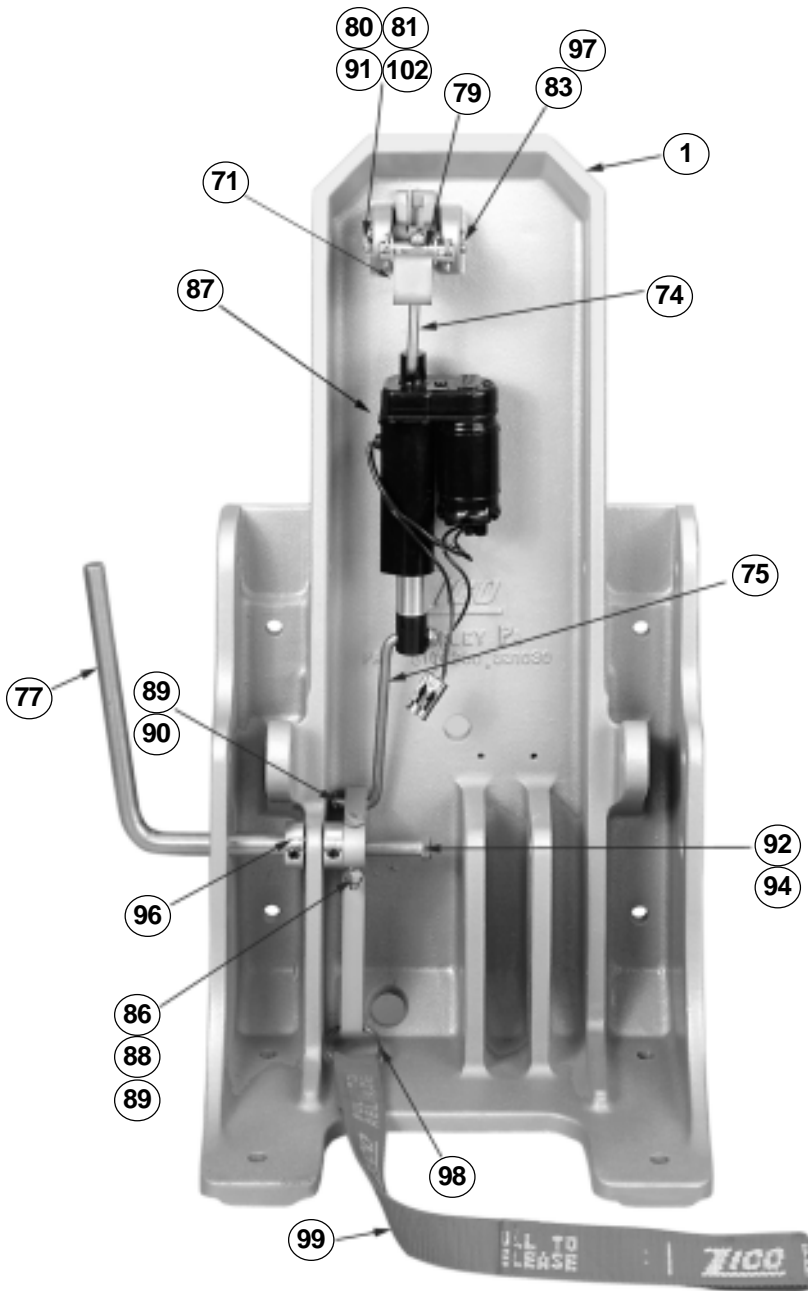
Latch Keeper
attached to
channel support
3097-105-154 or
3097-105-155.
Parts 72, 73, 82,
84, 85 & 100.





Use eye protection while working with spring (81)
 Use extreme care when loading and unloading spring on tool (102)
 Remove and discard tool after pin (83) is installed

FIGURE 26.
COMPONENT PARTS FOR MANUAL AND ELECTRIC
LOCKING SYSTEMS - EXPLODED VIEW



QUIC-LIFT™ Ladder Access Systems are now available with either a manual or electric locking system. This page covers the electric system.

The Model LAS base casting has been changed. This new style base casting became available March 23, 1998.

The base casting for the Model LAS-BHM Bulk Head Mount System has also been changed and has been in use since September 16, 1998.

If your system predates the above dates, the new base will be required in addition to the electric locking system.

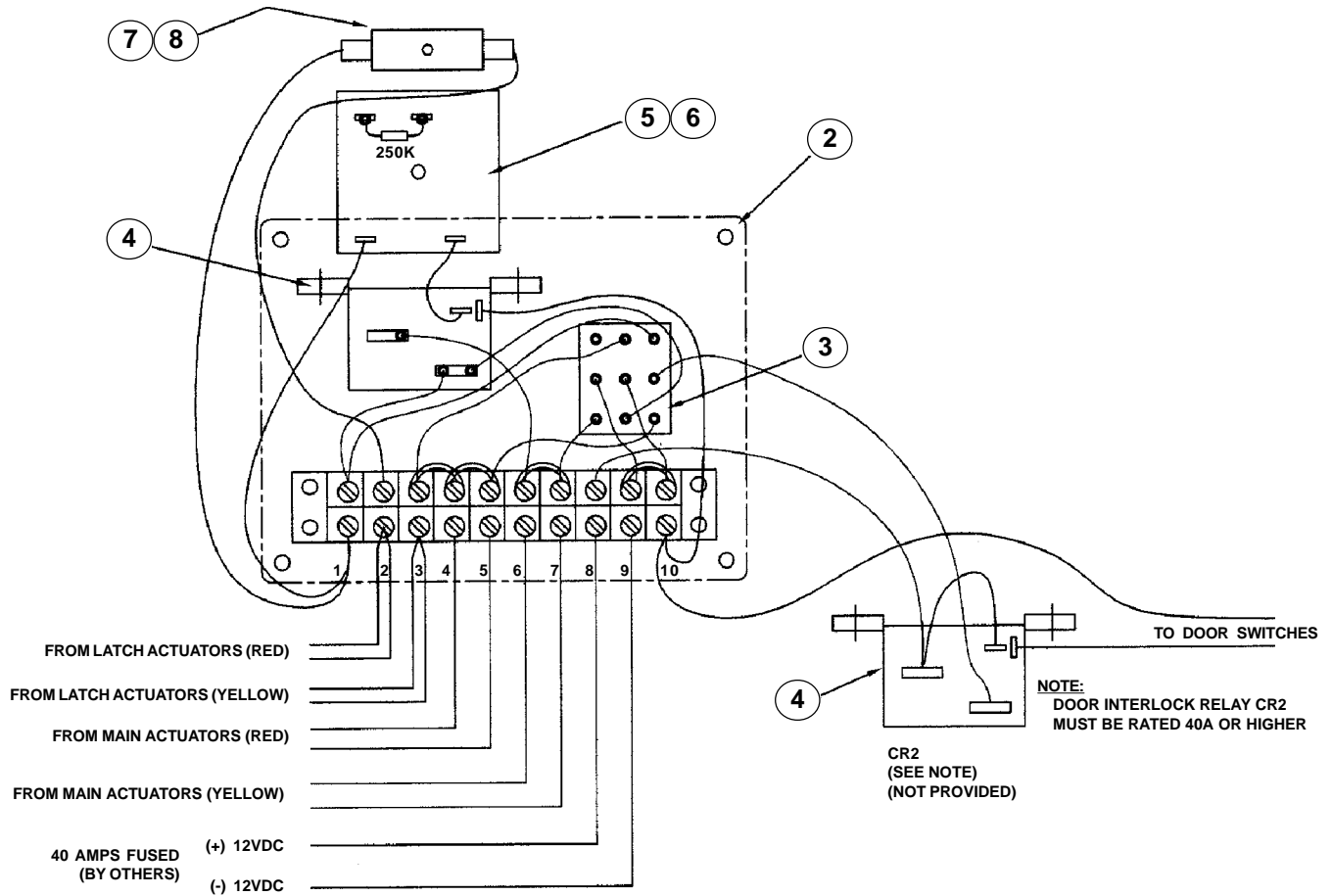
The electric locking system provides a positive means of retaining the ladders.

Parts list provided on pages 34 and 35. For wiring information see pages 37 and 38.

Model LLAS-ELS shown for use with Model LAS Systems
Model LLAS-BHM-ELS is used with Model LAS-BHM Systems

Press down on the operating switch and the small electric actuator opens the locking mechanism. After a momentary delay, the main electric actuator lowers the system.

FIGURE 27.
ELECTRIC LOCKING SYSTEM



ITEM NO.	PART NO.	DESCRIPTION	QTY.
1	3097-285-113	Nameplate (not shown)	1
2	3097-285-115	Mounting Plate	1
3	3097-285-117	Switch, 3P2T MOM	1
4	3097-285-119	Relay	1
5	3097-285-121	Timer	1
6	3097-285-123	Resistor, 250K-Ohm; 1/4W	1
7	3097-285-125	Fuseholder	1
8	3097-285-127	Fuse, 1/4ø x 1-1/4, 15 Amp	1
9	3097-285-129	Sub-Plate	1
10	3097-285-131	Terminal Block, 10 POS	1
11	3097-285-133	Jumper, Term	4

FIGURE 28.
WIRING PICTURAL FOR LLAS-ELS ELECTRIC LOCKING SYSTEM
SHOWING DOOR INTERLOCKS

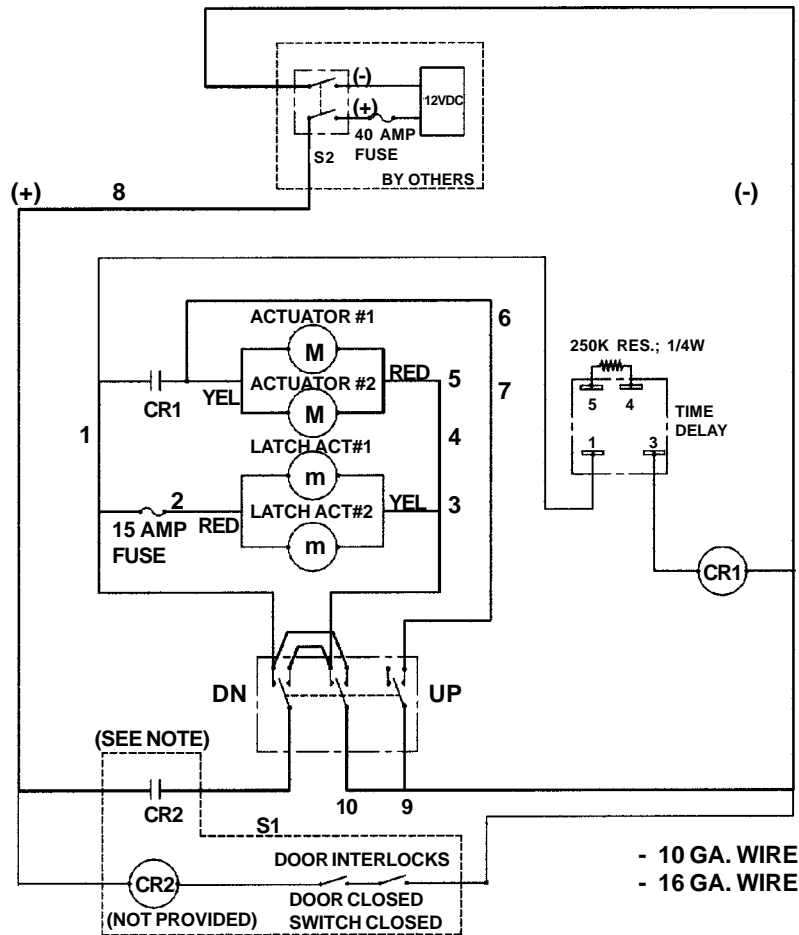


FIGURE 29.
WIRING SCHEMATIC FOR LLAS-ELS ELECTRIC LOCKING SYSTEM
SHOWING DOOR INTERLOCKS

Mode of Operation

- Turn on power to LAS unit - S2 (by others)
- Close all interlocked doors. (Device will not operate or will stop anytime an interlock is broken.)

Down Mode

- Actuate switch and hold in the down position - (S1).
- The latch actuator will start to unlock the latch, there will be a one (1) second delay after the latch actuator stops to ensure complete latch dis-engagement.
- Ladders will start to move down.
- At full down position release the switch.

Up Mode

- Actuate the switch and hold in the up position (S1).
- Both the lock actuator and main actuators will extend simultaneously.
- Hold the switch until both units have reached full up position (you'll hear ratcheting sound).

In the event the small electric actuator fails to operate, the lock may be de-activated by pulling outward on the strap (99) or pushing back on the handle (77).

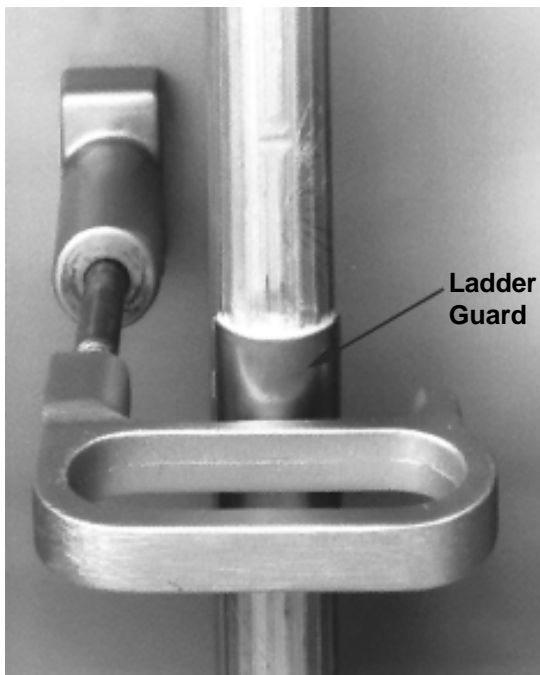
NOTE: Relay CR2 for door interlock must be rated 40A or higher.



Kit contains one tube of epoxy and two stainless steel rung protectors.

Instructions for Use:

1. Clean rungs with mild soap and water. Let dry.
2. Mark mounting location on rung.
3. Follow instructions for mixing the epoxy.
4. Spread epoxy evenly on the inside of the two rung protectors.
5. Clamp the rung protectors onto the rungs, using light pressure.
6. Let dry for 24 hours.
7. Place back into service.



Rung protector installed showing proper placement. Old style handle assembly showing handle retainer casting.

NOTE: Ladder manufacturer's have kits available to prevent wear of the rungs from contact with the ladder beams. We strongly suggest they be used to extend the life of your ladder.

**FIGURE 30.
LADDER GUARD KIT
MODEL LAS-LGK**

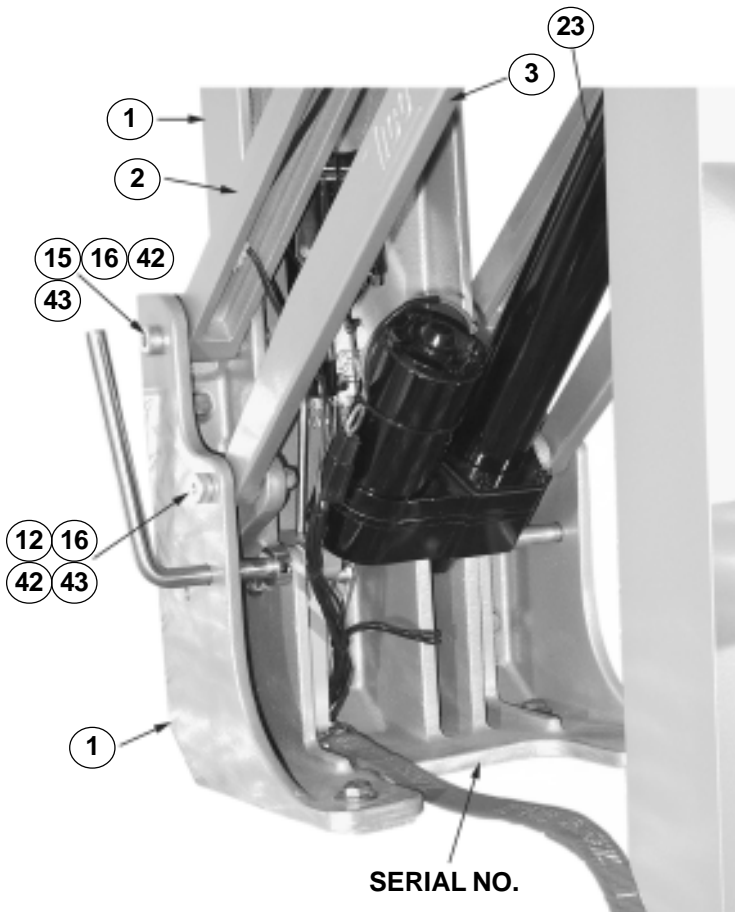


FIGURE 31.
LAS-___ COMPONENTS
 See Chart 1 Parts List
 Page 14 and
 Figure 3 Drawings
 Page 15

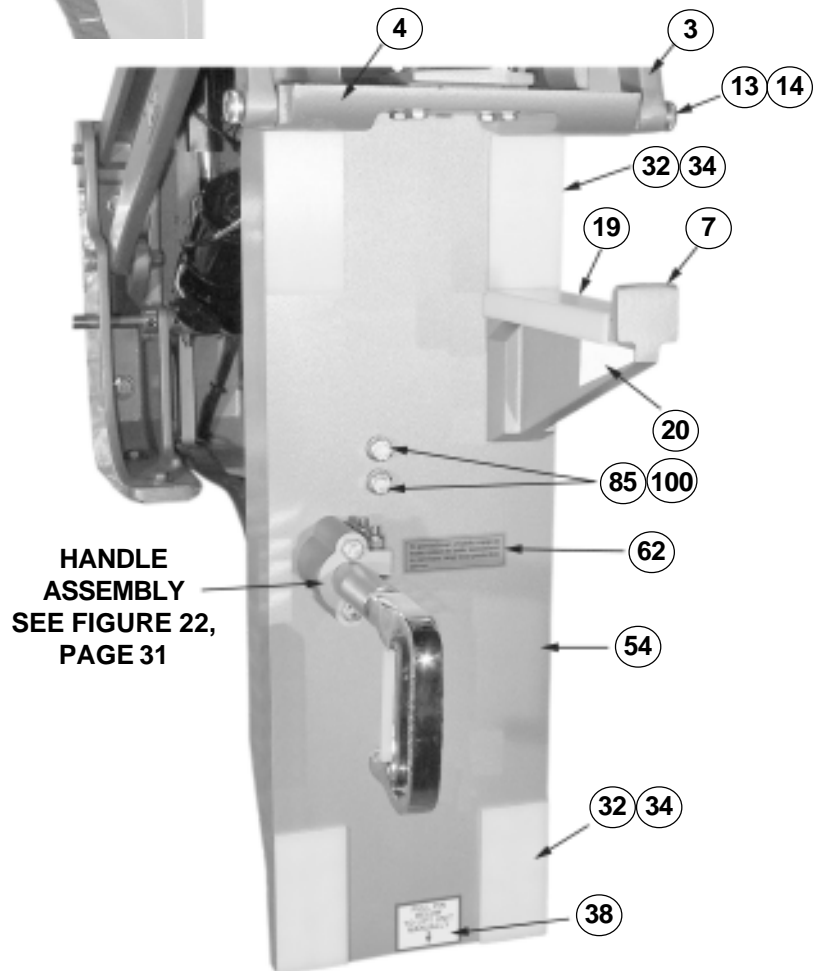


CHART 8. LAS PROBLEM SOLVING

PROBLEM:

Units are running out of synchronization.

- * Make sure the serial numbers of the units match. The serial number is located near the bottom center of each base casting as you are facing the unit. These units are timed as pairs. Two different units will not run at exactly the same speed. Units are not interchangeable. Do not use the number on the actuator but on the base castings.

- * Check to make sure the ladders are evenly placed on the system. There should be the same number of rungs hanging off each end of the system.

- * With an electronic tester, measure the voltage just before the actuators. The actuators should have quick disconnect clips about six inches before the motor. If the voltage differs by 0.5 volts or more, adjustments will have to be made to your wiring.
- * Check the wire to the actuators for proper gauge. Gauge size depends on length of wire. Consult a qualified electrician for gauge size.
- * Wires leading from the power source to each actuator should be the same length within a few feet.
- * Follow the wire path from the power source to the electric actuators. Look for door interlock switches (switches that prevent the unit from operating if a door is open) that are wired directly through the power wire. These switches are rarely rated for the amperage needed to operate the system. This will have a major adverse effect on the system. For most applications 10 gauge wire is sufficient. Power must be run directly to the switch, then directly to the actuator. Switches must be wired using relays rated for at least 30 amps.

- * Units make a clicking noise when they reach the end of the stroke.
The units will never run at exactly the same speed. During normal operation the unit should be run until both begin ratcheting. The actuators have built-in clutches and the noise that occurs at the end of the stroke is not causing any damage to the units.

SOLUTION:

Use only LAS systems with matching serial numbers. Call Ziamatic if serial numbers do not match.

Space ladders evenly or counter-weight the lighter side.

See Below

Wire must be replaced if under-sized.

Have a qualified technician add wire to the shorter length until they are even.

Have a qualified electrician rewire the system so that the door interlock switches are wired through relays.

This is a normal feature of the actuators.

(This page intentionally left blank.)

(This page intentionally left blank.)

WARRANTY REGISTRATION

PLEASE MAIL OR FAX A COPY TO ZICO TO REGISTER YOUR UNIT

FIRE DEPARTMENT NAME: _____ CONTACT PERSON: _____

PHONE NO. _____ FAX NO. _____

STREET ADDRESS: _____ P.O. BOX: _____

CITY: _____ STATE: _____ ZIP: _____

MODEL NO. (CHECK ONE):
_____ LAS-775 _____ LAS-BHM-775 _____ HSS-SAT-10
_____ LAS-975 _____ LAS-BHM-975
_____ LAS-1200 _____ LAS-BHM-1200

SERIAL NO. ON UNIT: (SEE PAGE 15 OR 17 FOR LOCATION) _____

INSTALLED ON: (VEHICLE MFG.) _____ DELIVERED: (DATE) _____

WAS UNIT INSTALLED ON: _____ NEW VEHICLE

_____ RETROFITTED ONTO EXISTING VEHICLE

OPTIONS INSTALLED ON YOUR UNIT (CHECK ALL THAT APPLY):

_____ LAS-FLB	_____ FLB	_____ LAS-LGK
_____ LAS-FLB/PPMB	_____ FLBA	_____ HARD SLEEVE TRAY
_____ PPMB-AA	_____ LAS-FLK	_____ OTHER _____
_____ PPMB-BB	_____ LAS-MSL	_____ OTHER _____

LADDERS MOUNTED ON THE UNIT:

DUO SAFETY _____ FT. EXTENSION, MODEL _____	ALCO LITE _____ FT. EXTENSION, MODEL _____
DUO SAFETY _____ FT. ROOF, MODEL _____	ALCO LITE _____ FT. ROOF, MODEL _____
DUO SAFETY _____ FT. _____, MODEL _____	ALCO LITE _____ FT. _____ MODEL _____

HARD SLEEVE MOUNTED ON THE UNIT:

_____ FT LIGHT WEIGHT _____ STRAINER ATTACHED TO SLEEVE _____ YES _____ NO
_____ FT STANDARD WEIGHT

WHERE DID YOU HEAR ABOUT OUR PRODUCT?

_____ MAGAZINE AD (SPECIFY) _____
_____ DEALER (SPECIFY) _____
_____ VEHICLE MFG. (SPECIFY) _____
_____ ANOTHER DEPARTMENT (SPECIFY) _____
_____ OTHER (SPECIFY) _____