



Fire, Safety, and Marine Equipment  
10 West College Ave., Yardley, PA, 19067-8337  
(215) 493-3618 • 1-800-711-FIRE • FAX (215) 493-1401  
www.ziamatic.com e-mail: zservice@ziamatic.com

## LAS-HA QUIC-LIFT™ SYSTEM



### **I. SYSTEMS AVAILABLE**

Refer to combination chart (page 16) for the correct combination number for the ladders you are using. Then contact Ziamatic Corp. to ascertain the LAS-HA system you require.

#### **A. Ladder Access System with Hydraulic Actuators (LAS-HA)**

- |    |                |                                                             |
|----|----------------|-------------------------------------------------------------|
| 1. | LAS-HA-ML      | Basic unit with manual lock                                 |
| 2. | LAS-HA-ML-775  | Complete unit with 7-3/4" ladder support with manual lock   |
| 3. | LAS-HA-ML-975  | Complete unit with 9-3/4" ladder support with manual lock   |
| 4. | LAS-HA-ML-1200 | Complete unit with 12" ladder support with manual lock      |
| 5. | LAS-HA-EL      | Basic unit with electric lock                               |
| 6. | LAS-HA-EL-775  | Complete unit with 7-3/4" ladder support with electric lock |
| 7. | LAS-HA-EL-975  | Complete unit with 9-3/4" ladder support with electric lock |
| 8. | LAS-HA-EL-1200 | Complete unit with 12" ladder support with electric lock    |

#### **B. Hard Sleeve System (HSS)**

- |    |               |                                                                                       |
|----|---------------|---------------------------------------------------------------------------------------|
| 1. | LAS-HA-ML-HSS | Hydraulic hard sleeve system with two 10' aluminum trays with manual locking system   |
| 2. | LAS-HA-EL-HSS | Hydraulic hard sleeve system with two 10' aluminum trays with electric locking system |

## II. STANDARD EQUIPMENT

The following items are included with each complete LAS or HSS System:

### A. Instruction Packet

Includes all information required to install a complete System. Wiring diagrams and parts lists are provided.

### B. Control Switch - (P/N 3097-105-144)

A double-pole double-throw momentary toggle switch is provided for operation of the System.

### C. Flashing Light Kit - Model No. LAS-HA-FLK (P/N 3097-720-000)

You may purchase the audio-visual alarm (see P/N 8047-125-000, Model AVA) or the relay, but they are no longer part of the System. NFPA 1901-96 requires flashing lights. These lights must flash unless the System is in the stored position.

## III. OPTIONAL EQUIPMENT

The following items may be added to any of the LAS or HSS Systems.

### A. LAS-FLB

Brackets are to be mounted on top surface of pivot support casting (item 4, page 15 and pages 22, 24 & 25). Folding ladder bracket (FLB or FLBA) must be ordered in addition to the LAS-FLB castings. This option allows you to carry a folding ladder in addition to your ladders or hard sleeves.

### B. HSS-TMC

Tray mounting castings allow you to carry one length of hard sleeve in addition to your ladders (LAS) or two lengths of hard sleeve (HSS). These castings mount on top of the LAS-FLB castings, which must also be ordered with this option (item H3, page 21 and pages 22, 23 & 24) along with tray mount hardware (HSS-TMH) and a 10 foot tray (HSS-SAT-10).

**Note: Failure to mount the hard sleeve tray using our tray mount casting (HSS-TMC) and tray mount hardware (HSS-TMH) will void your warranty. See Figure 11, page 22 for mounting information.**

**C. LAS-FLB/PPMB**

This square tube mount may also be used in conjunction with the LAS-FLB castings. This option allows mounting of pike pole mounting brackets in addition to folding ladder brackets. May not be used if option D is used (Figure 16, page 25).

**D. PPMB-\_\_**

Pike pole mounting brackets may be attached directly using pre-drilled holes on the top side of the inside arm castings (item 2, page 15 and Figure 17, page 25). Either single or double mounts may be used. Refer to the current ZICO catalog to order the pike pole mounting brackets required. This option may not be used if option C is selected.

**E. 1-1/2" Spacer Set (P/N 3097-250-000)**

In some instances the Ladder Access Systems must be raised up to accommodate extra-wide ladders. When this occurs, a set of four 1-1/2" high spacers will be required for proper mounting of the ladders. Required whenever the 27" long channel (item 31, page 15) is needed (see Chart 2, page 16).

**F. LAS-LGK**

Ladder guard kit contains one tube of epoxy and two stainless steel guards. The guards may be attached to the ladder rungs to prevent wear and possible damage as the result of the locking handle's contact with the rung (see Figure 28, page 37).

**G. LLAS-HA-MLS**

The manual locking system (Figure 22, page 31) comes standard on the LAS-HA. It provides a positive means of retaining the ladders. The lock must be deactivated prior to operating the electrical control. This is done by pulling outward on the strap (item 99, page 31) or pushing back on the handle (item 78, page 31).

**H. LLAS-HA-ELS**

The electric locking system (Figure 25, page 34) is activated by pressing down on the operating switch allowing the small electric actuators to open the locking mechanisms. After a momentary delay, the main electric actuators lower the System. The electric locking system may also be operated manually (see page 34).

#### **IV. GENERAL INSTALLATION INFORMATION**

The Ladder Access System was designed for ladders meeting the current NFPA 1931 standard. Systems accommodate most ladder combinations. However, for ladders over 35 feet or with tormentor poles, contact Ziamatic Corp. to ascertain if they may be used with an Access System. Combinations (see page 16) 36, 44, 53, 63, 72, 80, 126, 128, 129, 130, 132, 133, 144, 152, 154, 157, 158, and 159 require ladder mounts in excess of 12 inches. Some of these combinations may be accommodated by adding spacers behind the ladder mount and retainer handle support, but this increases the mounting depth and the ladders may protrude excessively beyond the side of the vehicle. We do not recommend mounting of these ladders.

**Note: The weight of ladders and/or hard sleeves may not exceed 300 pounds with any of the Ladder Access Systems.**

##### **A. Mounting Points**

The Ladder Access devices should be placed symmetrically in reference to the ladder. The same number of rungs should extend past each ladder support (page 20). This will ensure that both units are lifting approximately the same weight (if this is not possible, contact Ziamatic Corp.). Bolt holes have been provided on both the vertical and horizontal mounting surfaces. Although the device may be securely mounted from the horizontal surface only, it is a great advantage to be able to use mounting bolts on the vertical surface as well. One-half inch thick backing plates should be used if using only vertical or horizontal hole sets for mounting (see Section V.A., last paragraph).

All bolts should have reinforcement structure added underneath the mounting surface where possible. Channel or rectangular tube should be used instead of flat plate as reinforcement. If aluminum plate is used, it should be 1/2" thick (see page 18).

##### **B. Electrical Circuit**

The control switch should be a momentary double-pole double-throw exterior 30 amp switch. We provide a switch with each system. It should be placed in such a position that the operator has full view of the QUIC-LIFT System and personnel that might come in contact with it. Using wires of equal length between power source and actuators will help to keep the actuators running in synchronization (see page 19 for wiring diagrams).

## **B. Electrical Circuit (continued)**

Several "Lock Out" circuits may be considered to prevent accidents from occurring. An ideal "Lock Out" system would only permit operation when the ignition switch is on, the transmission is in park, and any obstructing compartment doors are shut. Because of the higher amperage required to operate the QUIC-LIFT System, a separate "Lock Out" circuit should be used (see electrical diagrams on page 19). The "Lock Out" circuit should be separated from the QUIC-LIFT System circuit by a relay. This will prevent damage to the existing wiring system. The QUIC-LIFT System circuit should be protected by a 75 amp fuse.

NFPA 1901-96 standard requires flashing lights to be provided, facing front and rear of the apparatus. Lights must flash whenever the System is out of the stored position. The audio visual alarm may still be ordered as an option (see model AVA, P/N 8047-125-000 in catalog).

## **C. Synchronization of Actuators**

If you experience any problems associated with the LAS-HA, we will require the serial number off of your device.

It is important to the operation of the QUIC-LIFT System that the actuators work in synchronization. The actuators may be out of sync a considerable amount before binding occurs, however, reducing the occurrence of this will increase the life of the actuators and prevent damage or wear to the ladders. Keeping the load evenly distributed on the two devices will help to keep the actuators running in synchronization (Figure 7, page 20).

**Do not permit personnel to hang, sit or stand on ladders or hose while stored on the QUIC-LIFT System.** If the unit is overloaded, an internal relief valve will open to prevent damage to the actuators and mechanical components.

We have extensively tested our QUIC-LIFT System and have found the normal life to be in excess of 5,000 cycles without failure. With reasonable care and maintenance, your QUIC-LIFT System should give you many years of excellent service.

## V. INSTALLING THE LADDER ACCESS SYSTEM

### A. Preparation for Mounting

Plan and lay out the entire installation before making any cuts or drilling holes in the body of the fire apparatus. This will keep "out of service" time to a minimum and also help to minimize mistakes. See Electrical System below before any holes are drilled into the apparatus.

Lay the two units on the shelf of the apparatus so that you can see where holes will be required for the mounting bolts. There should be sufficiently sized flat surface underneath the mounting holes free of seams and obstructions where the bolts will pass through. Raise the ladders near the two units to determine where they will lay when installed. The ladders must be evenly supported by each unit (the same number of rungs should extend on the outer side of each ladder support).

When the ladder is raised and lowered in this position, it should clear protruding objects on the apparatus such as emergency lights, hand rails, etc. Make sure that when the ladders are in the up position they do not obstruct cross lays or hose reels.

Measure the "resting" depth of your ladder combination to determine how far your ladders will protrude out from the hose bed wall (add depth of 6" for the retracted LAS System). In the event that the inner arm casting (item 2, page 15) come into contact with the stiffening rib at the top of the hose bed, you may have to notch out the stiffening rib to recess the device (see page 18). In the event that the stiffening rib is notched, the exposed metal surfaces should be painted and covered with an edge guard material. In addition, and in particular, if the stiffening rib is notched, you may wish to add a backing plate (page 18) on the inside surface of the hose bed wall. The plate will reinforce the hose bed wall and provide a good mounting support for the QUIC-LIFT System. The edges should be rounded off, on the side next to the hose, and flat head bolts should be used to mount the plate.

Bolts 3/8" or larger should be used to mount the base castings to the fire apparatus. When the bases will only be mounted to the hose bed wall or only mounted to the shelf deck, 1/2" bolts should be used with substantial backing plates (page 18) and supports. If you are installing the QUIC-LIFT devices to only one surface, we suggest you contact one of our technicians before beginning.

## **B Electrical System**

Now that you are sure of your mounting position, you may begin to lay out your electrical wiring (pages 19, 26, 28, 35 and 36). At this time, it is a good idea to remove the units from the shelf and "C" clamp them to a table so that the units will swing out away from the table when lowered. Units should be mounted the same distance back from edge of table as they would be on the shelf of your apparatus. Be sure the table is secured by adding a counterweight to the other side before lowering the units. Place ladders onto the ladder mount castings (item 7, page 15) just as they will be stored on the apparatus. Determine where wires can be run so they will not be visible from the outside of the apparatus. We recommend all electrical connections be soldered as this method is superior to crimp connections. Measure the required run lengths of each wire (see page 19 for proper wire diameter).

Make up a wiring harness using wires longer than the required run lengths. Temporarily make all wire connections so you can test the system. With the table properly secured, you should be able to operate the units with the ladders or hard sleeves attached. Be sure the ladders will clear the edge of the table before drilling any holes in the apparatus. If they do not, spacers may be required (see Section III, E., page 3).

The flashing light kit (model LAS-HA-FLK) must be installed. The wiring diagram for the flashing lights may be found on page 26.

## **C. Mounting Suggestions**

A "WARNING" label (part number 3097-105-149, item 30, page 14) is supplied with each QUIC-LIFT System. The pressure sensitive label must be mounted by the electrical control switch. All apparatus operators must be instructed to keep area in front of ladders clear of personnel when the QUIC-LIFT System is being raised or lowered.

Before starting the installation, you should make sure you have all necessary tools and materials. This should include matching touch-up paint, edge trim (for cut outs), fender protector cloths and removable tape (to protect paint), necessary hardware, wire connectors, cable ties, burr remover, vacuum cleaner (for metal filings), edge guards (for wiring), drills, drill gun, wrenches, step ladders, etc. Be sure to allow yourself sufficient time to make a proper installation. You will probably have to remove the hose from the hose bed.

Following these simple instructions should make your installation easy and professional.

## **VI. TROUBLE SHOOTING**

All units are tested after final assembly to ensure proper operation and adjustment. No further adjustments should be required unless excess vibration is noted (see VI. D., page 9).

### **A. Ladder Wider Than Ladder Support**

If the proper ladder combination is specified at the time of ordering, this problem should not occur. The standard support channel (item 31, page 15) is 25-1/4" long. We can also provide a longer support channel (part number 3097-700-11) which is 27" long. See Chart 2, page 16, for combinations requiring the 27" long channel. Spacer set (part number 3097-250-000) must be ordered with these combinations.

### **B. One Actuator Running Two Or More Seconds Slower Than The Other**

When one actuator is running more than two seconds behind the other, it is normally due to some type of resistance in the wiring system. Check all wire connections to make sure they are secure. Make sure to fully extend both actuators at the end of each up and down cycle. If they are still greatly out of sync, after checking the wiring and fully extending the units at the end of each cycle, you may switch the actuators to confirm if the problem is in the wiring system. After removing the ladders, remove the shoulder bolt (item 10, page 15) from each unit and nut/bolt assembly (items 10, 25 and 26, page 15) to remove the actuator. Switch the two actuators and reassemble. If the rear actuator was running slower before switching and is still running slower, there is a problem in the wiring.

### **c. Excess Vibration May Cause Failure Of One Or More Castings**

A "WARNING" label (part number 3097-105-158, item 58, page 14) has been attached to each set of castings. If, after installing the System and ladders, you note excessive movement of the ladders while operating the vehicle, check the following (referring to drawings on pages 11 & 15 and bill of materials on page 14 and information provided below). Remove the ladders before proceeding.

1. Actuator Yoke Adjustment (see Figure 1, page 11)
  - a. Check to see if the hook and latch inside the system are engaged (items 71 & 72). If the latch is disengaged, proceed as follows. If it is engaged, proceed to Section VI. D. 2.



- b. To adjust (refer to Chart 2, page 14 for item numbers in parenthesis):
- i. Lower system approximately halfway down and remove ladders.
  - ii. Support the system in its current position. This can be done one of two ways: by strapping the top of the inside arm (2) to a fixed support, or by supporting the bottom of the channel (31) by setting it on something such as a ladder.
  - iii. Remove the nut/bolt assembly (10, 25 & 26) at the lower mounting point of the actuator (21).
  - iv. Loosen the bottom jam nut (9) on yoke. **Note: Do not loosen the upper jam nut on the yoke.**
  - v. To decrease outward lean, rotate the yoke (8) counter clockwise. To increase outward lean, rotate the yoke (8) clockwise.
  - vi. Reattach the lower mounting point of the actuator (21) to the yoke (8) with the nut/bolt assembly (10, 25 & 26).
  - vii. Raise the system all the way up to its stored position.
- c. Check to see if hook (Chart 7, page 35, item 72) inside the system is latching. Try unlocking the latch (Chart 7, page 35, item 71) by pulling on the strap (Chart 7, page 35, item 99). If the system is not latching, readjust the system again by decreasing the outward lean. If the latch is unnecessarily difficult to unlock, readjust the system again by increasing the outward lean. See Section VI. D. 1. b. if either of these scenarios are true.
- d. Now, re-tighten jam nut (9) and see Section Vi. D. 2 to readjust the Adjustment Stop (5 & 6).

## 2. Adjustment Stop

- a. Check bolt (5) and locking nut (6) to see if they are tight. If loose, proceed as follows to adjust:
  1. Lower the unit partially, loosen locking nut and turn hex head bolt in, one or two turns, towards the inside arm casting.

2. Raise the unit to the full up position.
3. Turn out on the bolt (5) until it is lightly snugged against the outside arm casting (3).
4. Lower the device partially and turn hex head bolt out an additional 3/4 turn. Hold bolt in this position and tighten locking nut.

When the devices are returned to the upright, closed position, they should be rigid and not move with hand pressure.

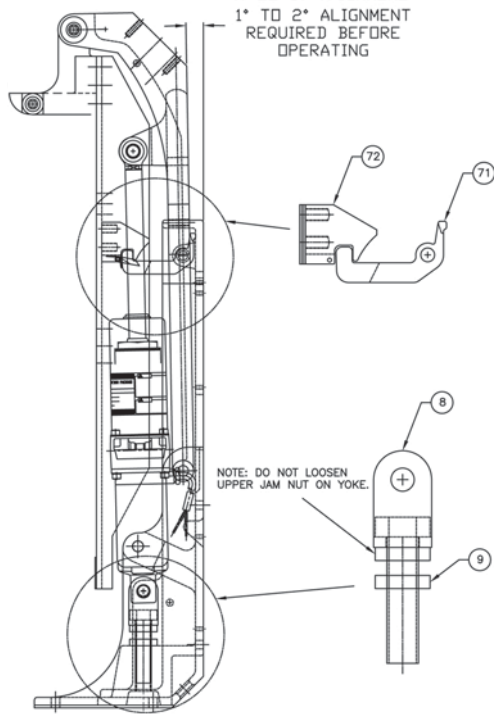
Check to see if the hook and latch (Figure 1, page 11, items 71 & 72) inside the system are engaged. If they are not, refer to Section VI. D. 1. in order to readjust the yoke (8).

#### **D. Emergency Operation**

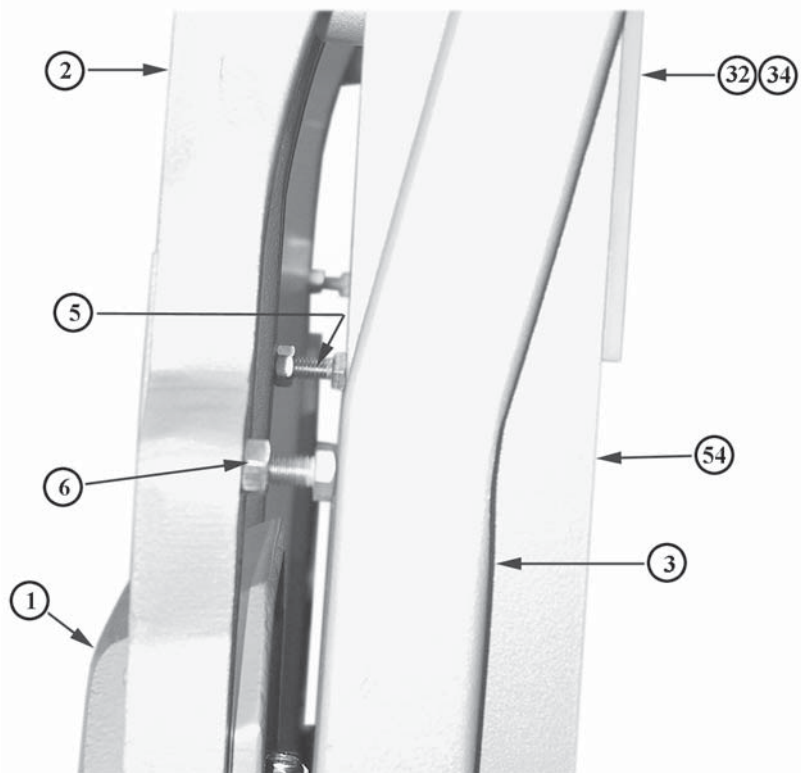
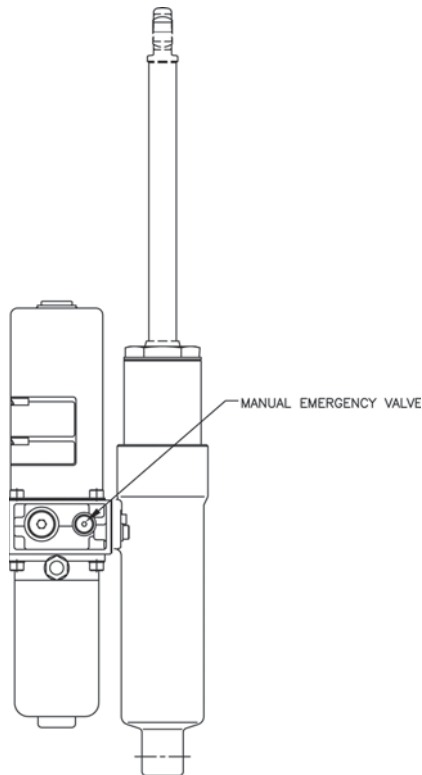
If the System fails to lower from the stored position, do not attempt to repair until the unit is returned to the station.

If the System fails to raise from the down position, the following emergency procedure may be used:

1. Remove the ladders from the system.
2. With one person holding the ladder mount casting (7), a second person should use a 3mm allen wrench to loosen the smaller Manual Emergency Valve on the front of the actuator (21), accessible through a hole on the channel (31), as shown on Figure 2, page 11.
3. Lift unit to its stored position and verify that the internal latch (Chart 7, page 35, items 71 and 72) has engaged.
4. Tighten Manual Emergency Valve.
5. Follow same procedure for the second unit.
6. Ladders can be repositioned onto the system for return trip to station.



**FIGURE 1**  
**ACTUATOR YOKE ADJUSTMENT (See Section VI. D. 1.)**



**FIGURE 2**  
**ADJUSTMENT STOP (See Section VI. D. 2.)**

## **VII. DRAWINGS, DIAGRAMS AND CHARTS**

### **A. Ladder Access System (LAS)**

1. Actuator yoke adjustment (Figure 1, page 11)
2. Adjustment stop (Figure 2, page 11)
3. Combination numbers for LAS Systems (Chart 2, page 16)
4. Standard model shown with optional spacer blocks under base casting (Figure 3, page 15)
5. Parts list - Model LAS-\_\_\_\_ (Chart 1, page 14)
6. Side view - Model LAS-\_\_\_\_ (Figure 4, page 17)
7. Common installation using stiffening/backing plate (Figure 5, page 18)
8. Electrical diagram for QUIC-LIFT Systems (Figure 6, page 19)
9. Front view of LAS System (Figure 7, page 20)
10. Handle assembly (Figure 20, page 28)

### **B. Hard Sleeve System (HSS)**

1. Frontal view of HSS system (Figure 8, page 20)
2. Model HSS hard sleeve system (Figure 9, page 22)
3. Model HSS parts list (Chart 3, page 21)
4. Hard sleeve system location and drilling instructions (Figure 11, page 22)
5. QUIC-STRAP system to retain hard sleeve (Figure 10, page 22 and Figure 12, page 23)
6. Hose tray support with hose tray (Figure 10, page 22 and Figure 13, page 23)

### **C. QUIC-LIFT System - Optional Equipment**

1. Model LAS-FLB castings attached to pivot support casting (Figures 10 & 11, page 22, Figures 14 & 15, page 24 & Figure 16, page 25)
2. HSS-TMC tray mount castings (Figure 9 and Chart 3, page 21, Figure 10, page 22 and Figures 12 & 13, page 26)
3. Model LAS-FLB/PPMB extrusion added to support PPMB-AA or PPMB-BB (Figure 16, page 25)
4. Model PPMB-AA or PPMB-BB pike pole mounting brackets attached directly to inside arm castings (Figure 17, page 25)
5. Part Number 3097-250-000 spacer set under base casting (Figure 3, page 15)
6. Model LAS-HA-FLK flashing light kit (pages 26 & 27)
7. Model LLAS-MLS manual locking system (pages 31 through 33)
8. Model LLAS-ELS electric locking system (pages 34 through 36)
9. Model LAS-LGK ladder guard kit (Figure 28, page 37)

## VIII. MAINTENANCE

### A. Periodic

Any time that ladders appear to be "loose", refer to Trouble Shooting (VI) and follow suggestions depending upon your specific problem.

### B. Semi-Annually Or At Scheduled Apparatus Lube Service

1. Adjustment stop (items 5 & 6, page 14 and 15) - If nut or bolt are loose, refer to adjustment directions (VI. D. 2., page 10 and Figure 2, page 11)
2. Lubrication - We suggest that all pivoting surfaces be sprayed, in the joints and pivot points, with CRC brand Stor&Lube, long-term lubricant and rust preventative #03032. Excess lubrication should be wiped off.
3. Actuator - We suggest the exposed shaft be cleaned and sprayed with WD40 or a similar light, moisture-repelling silicon type lubricant.

### C. Pressure Washing

**Do not operate pressure washer around or near the actuators.** Excessive pressure may allow soap and water to blow past the seal, damaging the actuator.

## IX. SERVICE

If you experience any problems with your Ladder Access System, please call us at 800-711-3473 for assistance. **Please have the serial number of your System available.** This number may be found on the upper front side of the base casting.

You may also refer to Chart 7, LAS Problem Solving, on page 38 for possible solutions for your questions.

## X. WARRANTY

A copy of the warranty registration **MUST** be returned to ZICO to ensure registration of your System (page 39).

# CHART 1. PARTS LIST

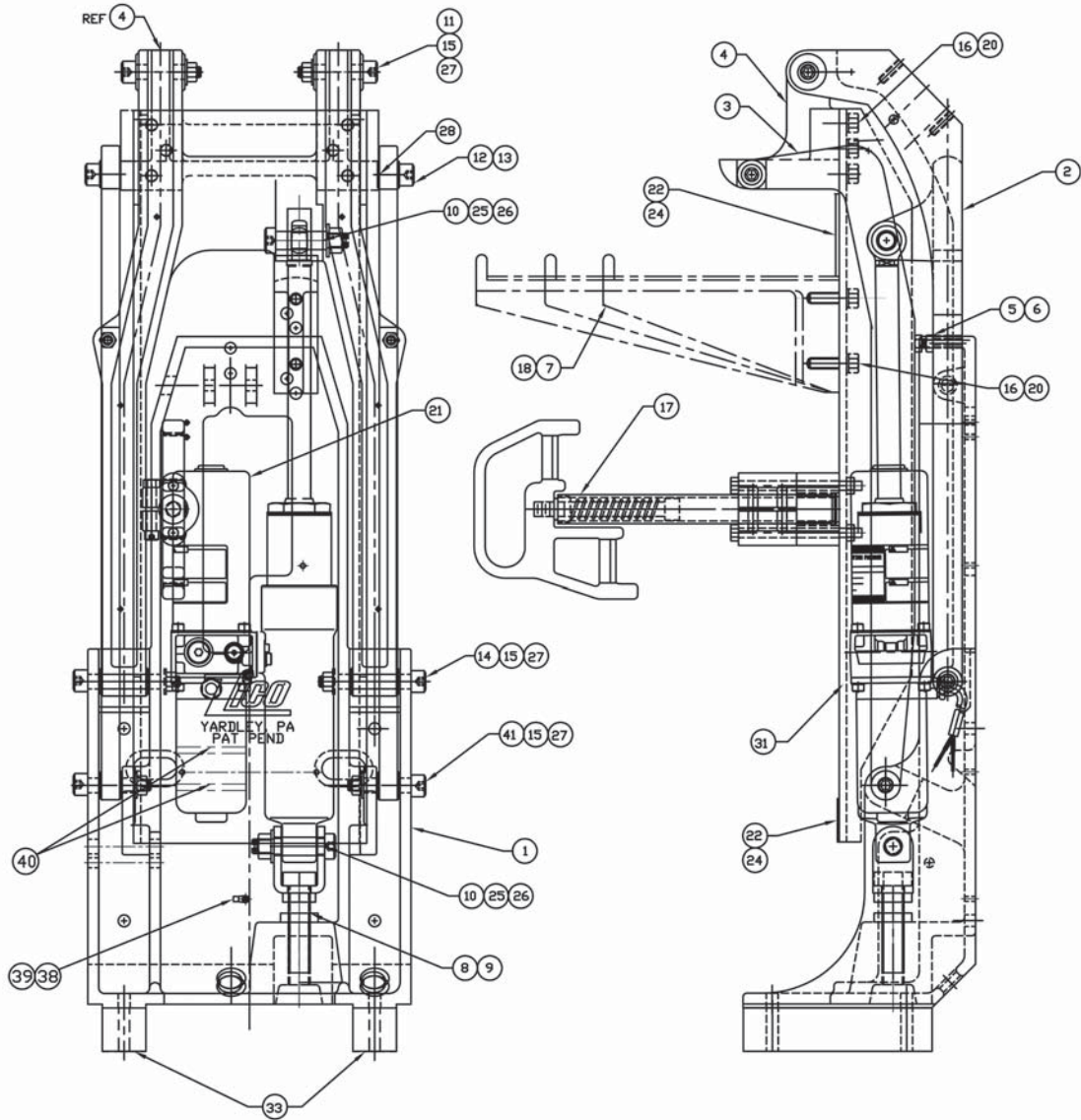
## MODEL LAS-HA-\_\_\_\_\_

ITEM NO.	PART NUMBER	NAME	MAT'L.	DESCRIPTION	MODEL NUMBERS			
					LAS-HA BASIC	LAS-HA 775	LAS-HA 975	LAS-HA 1200
1	3097-700-101	Base Casting	Alum		1	1	1	1
2	3097-700-103	Inside Arm Casting	Alum		1	1	1	1
3	3097-105-103	Outside Arm Casting	Alum		2	2	2	2
4	3097-105-104	Pivot Support Casting	Alum		1	1	1	1
5	9110-103124	Hex Hd Bolt	SST	5/16-18 x 1-1/2	2	2	2	2
6	9112-103100	Hex Hd Nut	SST	5/16-18	2	2	2	2
7	3097-105-111	Ladder Mount Casting	Alum	Size 7-3/4		1		
	3097-165-107	Ladder Mount Casting	Alum	Size 9-3/4			1	
	3097-105-135	Ladder Mount Casting	Alum	Size 12				1
8	3097-700-105	Yoke	SZP		1	1	1	1
9	9015-207500	Jam Nut; 3/4-16; 5/16" Ht	SZP		1	1	1	1
10	9010-3162228	Shoulder Bolt (1/2-13)	SZP	Size 5/8 x 1-3/4	2	2	2	2
11	9010-315028	Shoulder Bolt (3/8-16)	SZP	Size 1/2 x 1-3/4	2	2	2	2
12		Liquid Threadlocker *		As Required	A/R	A/R	A/R	A/R
13	9010-315012	Shoulder Bolt (3/8-16)	SZP	Size 1/2 x 3/4	2	2	2	2
14	9010-315048	Shoulder Bolt (3/8-16)	SZP	Size 1/2 x 3	2	2	2	2
15	9113-173700	Hex Hd Locknut	SST	Size 3/8-16	6	6	6	6
16	9114-203700	Lock Washer	SST	Size 3/8 I.D.	6	8	8	8
17	3097-700-910	Handle Assembly			1	1	1	1
18	3097-105-119	Wear Strip	Plastic	7-5/8" Long		1		
	3097-165-119	Wear Strip	Plastic	9-3/4" Long			1	
	3097-145-119	Wear Strip	Plastic	12-1/16" Long				1
19	3097-105-120	Reflective Tape	P.S.			1	1	1
20	9110-333718	Socket Hd C/S	SST	Size 3/8-16 x 1-1/8	6	8	8	8
21	3097-700-107	Hydraulic Actuator		See Note	1	1	1	1
22	3097-105-116	Ladder Pad	Plastic	Size 1/8 Tk x 2 x 3		4	4	4
23	3097-105-133	Wiring Diagram *			1	1	1	1
24	3097-105-161	Adhesive - Double Sided		2 x 3 (Use with Item 23)	A/R	A/R	A/R	A/R
25	9014-115000	Flatwasher	SZP	Size 1/2 I.D.	2	2	2	2
26	9113-175000	Hex Hd Locknut	SST	Size 12-13	2	2	2	2
27	9014-113700	Flat Washer	SST	Size 3/8 I.D.	6	6	6	6
28	9114-115000	Spacer	SST	Size 3/8 I.D.	2	2	2	2
29	3097-105-144	Switch *			1	1	1	1
30	3097-105-149	Label *	P.S.	Keep Clear Of Area	1	1	1	1
31	3097-700-109	Channel Support	Alum	25-1/4" Long	1	1	1	1
	3097-700-111	Channel Support	Alum	27" Long	OPT	OPT	OPT	OPT
32	3097-720-000	Flashing Light Kit *			1	1	1	1
33	3097-105-157	Base Spacer	Alum	(2 Required)	OPT	OPT	OPT	OPT
34	3097-105-158	Label *	P.S.	Vibration Warning	1	1	1	1
35	3097-105-159	Label *	P.S.	"Caution: Do not..."		1	1	1
36	3097-105-162	Label *	P.S.	"To Prevent Wear..."		1	1	1
37	3097-105-163	Tag, "Factory Set"	Paper			1	1	1
38	3097-720-103	Cable Tie	Nylon	#10 Mtg Hole; 8.5" Lg.	1	1	1	1
39	9025-132008	Screw, Self Tap; Pan Hd	SZP	#10-32 x 1/2" Lg.	1	1	1	1
40	0000-000-184	Cable Tie	Nylon	11" Lg.	2	2	2	2
41	9010-315032	Shoulder Bolt (3/8-16)	SZP	Size 1/2 x 2	2	2	2	2
42	3097-105-145	Boot, Toggle Switch *			1	1	1	1
43	3093-005-156	Connector, Heat Shr. *		14-16 Awg.; Blue	2	2	2	2

\* = NOT SHOWN

A/R = AS REQUIRED

OPT = OPTIONAL



**FIGURE 3. MODEL LAS-HA-\_\_\_\_\_**  
**STANDARD MODEL SHOWN WITH OPTIONAL**  
**SPACER BLOCKS UNDER BASE CASTING**  
 SEE CHART 2 FOR COMBINATION NO.'S  
 REQUIRING SPACER BLOCKS

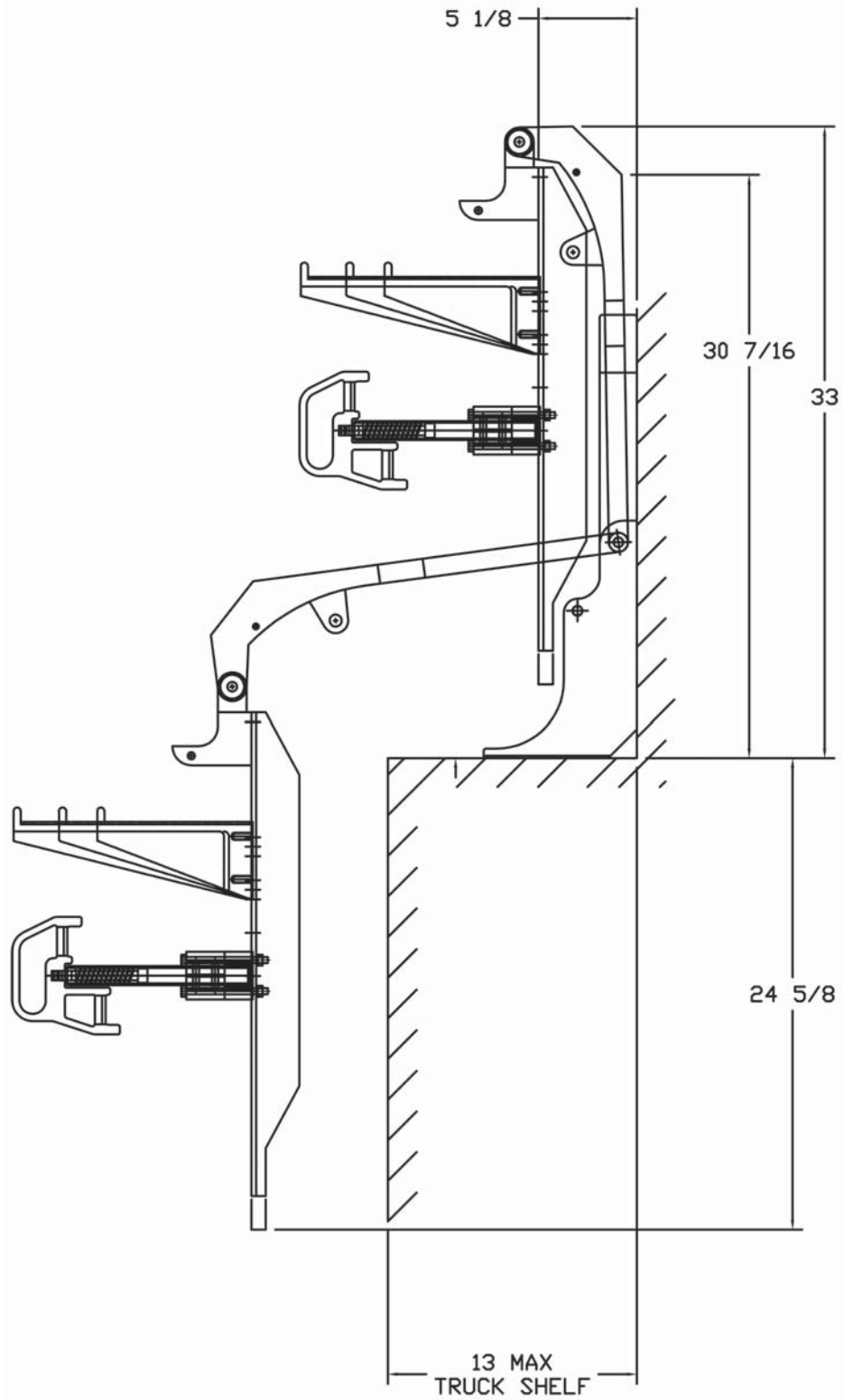
## CHART 2 COMBINATION NUMBERS FOR LAS SYSTEMS

<u>EXTENSION LADDER</u>	<u>ROOF LADDER</u>										
	<u>Alco Lite</u>	PRL 8' - 20' ALP-100 8'-20'	FRL 8' - 20' ALP-F-415 8'-20'	TRL 12' - 28' ALP-015 12'-28'	<u>Duo Safety</u>	Y.G.R. 10'-20'	775 10'-14'	875 16'-20'	1275 25'-30'	575C 10'-25'	575C 30'
<b>Alco Lite 2 Section</b>											
TEL 20' - 35' ALP-020 20'-35'		1	2	3		4 <sup>(1)</sup>	5	6	7	8 <sup>(1)</sup>	9 <sup>(1)</sup>
PEL 12' - 24' ALP-200-12'-24'		10	11	12		13	14	15	16	17	18
PEL 28' - 35' ALP-200 28'-35'		19	20	21		22	23	24	25	26	27
FEL 12' - 35' ALP-F-420 12'-35'		28	29	30		31	32	33	34	35 <sup>(1)</sup>	(3)36 <sup>(1)</sup>
<b>Alco Lite 3 Section</b>											
TEL3 24' - 35' ALP-030 24'-35'		37 <sup>(1)</sup>	38 <sup>(1)</sup>	39 <sup>(1)</sup>		40 <sup>(1)</sup>	41 <sup>(1)</sup>	42 <sup>(1)</sup>	43 <sup>(1)</sup>	(3)44 <sup>(1)</sup>	45
ALP-030N 24'-35'		46 <sup>(1)</sup>	47 <sup>(1)</sup>	48 <sup>(1)</sup>		49 <sup>(1)</sup>	50 <sup>(1)</sup>	51 <sup>(1)</sup>	52 <sup>(1)</sup>	(3)53 <sup>(1)</sup>	54
PEL3 24' ALP-300 24'		55	56	57		58	59	60	61	62	(3)63
PEL3 28' - 35' ALP-300 28"-35'		64	65	66		67	68	69	70	71	(3)72
FEL3 28' - 35' ALP-F-430 28'-39'		73	74	75		76	77	78	79	(3)80	81
<b>Duo Safety 2 Section</b>											
Y.G.E.-2 16'-35'		82 <sup>(1)</sup>	83 <sup>(1)</sup>	84 <sup>(1)</sup>		85 <sup>(1)</sup>	86 <sup>(1)</sup>	87 <sup>(1)</sup>	88 <sup>(1)</sup>	89 <sup>(1)</sup>	90 <sup>(1)</sup>
900 20'-24'		91	92	93		94	95	96	97	98 <sup>(1)</sup>	99 <sup>(1)</sup>
1200 28'-35'		100 <sup>(1)</sup>	101 <sup>(1)</sup>	102 <sup>(1)</sup>		103 <sup>(1)</sup>	104 <sup>(1)</sup>	105 <sup>(1)</sup>	106 <sup>(1)</sup>	107 <sup>(1)</sup>	108 <sup>(1)</sup>
500-C 14'-24'		109 <sup>(1)</sup>	110 <sup>(1)</sup>	111 <sup>(1)</sup>		112 <sup>(1)</sup>	113 <sup>(1)</sup>	114 <sup>(1)</sup>	115 <sup>(1)</sup>	116 <sup>(1)</sup> <sub>(2)</sub>	117 <sup>(1)</sup> <sub>(2)</sub>
500-C 28'-35'		118 <sup>(1)</sup>	119 <sup>(1)</sup> <sub>(2)</sub>	120 <sup>(1)</sup>		121 <sup>(1)</sup> <sub>(2)</sub>	122 <sup>(1)</sup>	123 <sup>(1)</sup>	124 <sup>(1)</sup>	125 <sup>(1)</sup>	(3)126 <sup>(1)</sup> <sub>(2)</sub>
<b>Duo Safety 3 Section</b>											
Y.G.E.-3 28'-35'		127 <sup>(1)</sup>	(3)128 <sup>(1)</sup>	(3)129 <sup>(1)</sup>		(3)130 <sup>(1)</sup>	131 <sup>(1)</sup>	(3)132 <sup>(1)</sup>	(3)133 <sup>(1)</sup>	134	135
925 22'-26'		136	137	138		139	140	141	142	143	(3)144
1225 28'-35'		145	146	147		148	149	150	151	(3)152	153
525C 28'-35'		(3)154 <sup>(1)</sup>	155	156		(3)157 <sup>(1)</sup>	(3)158 <sup>(1)</sup>	(3)159 <sup>(1)</sup>	160	161	162

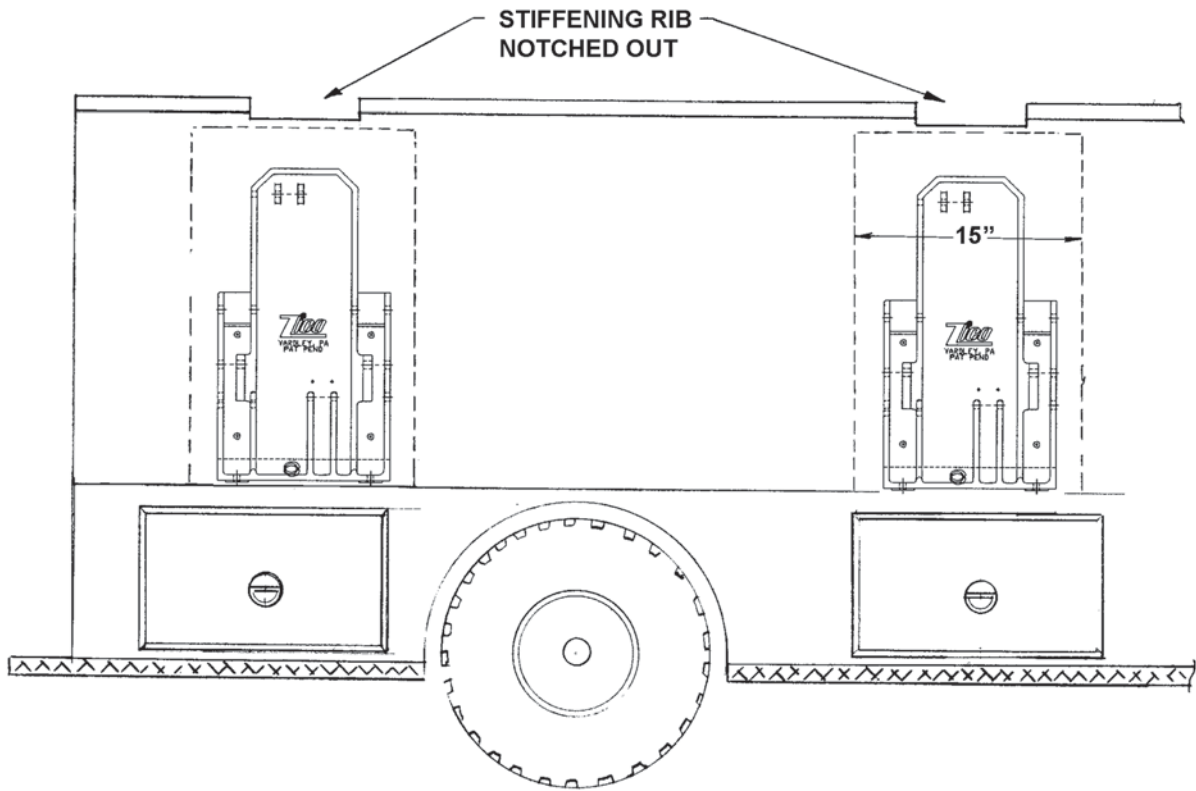
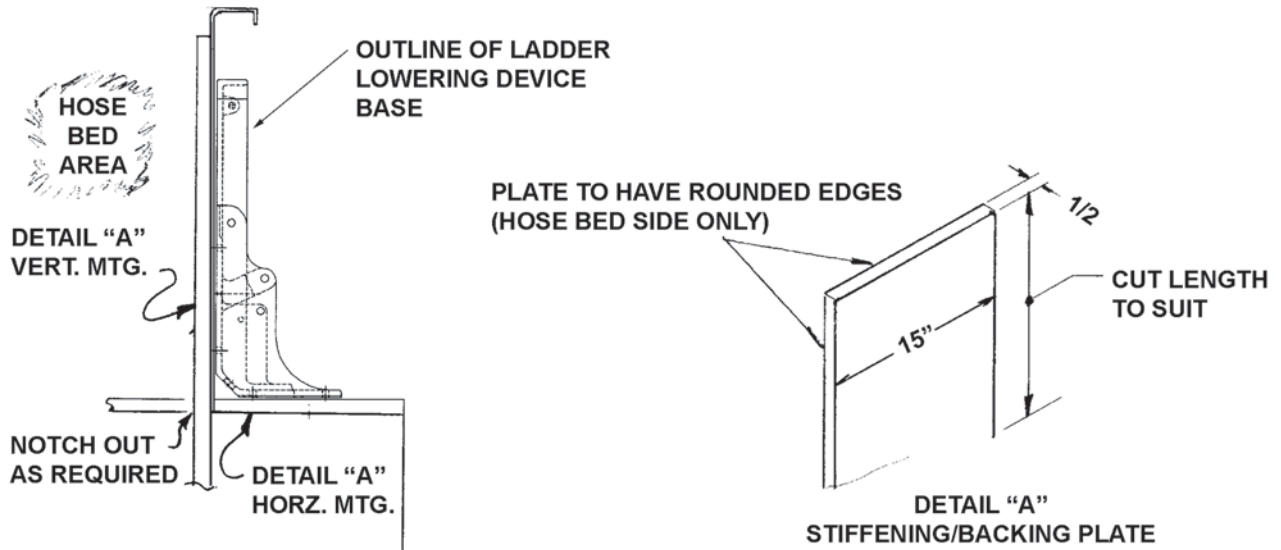
**NO LADDERS WITH POLES AND NO LADDERS OVER 35' (UNLESS SPECIAL ORDER WITH APPROVAL)  
WEIGHT OF LADDERS AND/OR HARD SLEEVE MAY NOT EXCEED 300 POUNDS**

(1) USE 27" LONG CHANNEL AND 3097-250-000 SPACER SET UNDER BASE CASTING  
 (2) EXTENSION LADDER WEIGHT RESTS ON ROOF LADDER  
 (3) USE 1" SPACER (3097-105-136) BETWEEN LADDER MOUNT CASTING AND CHANNEL

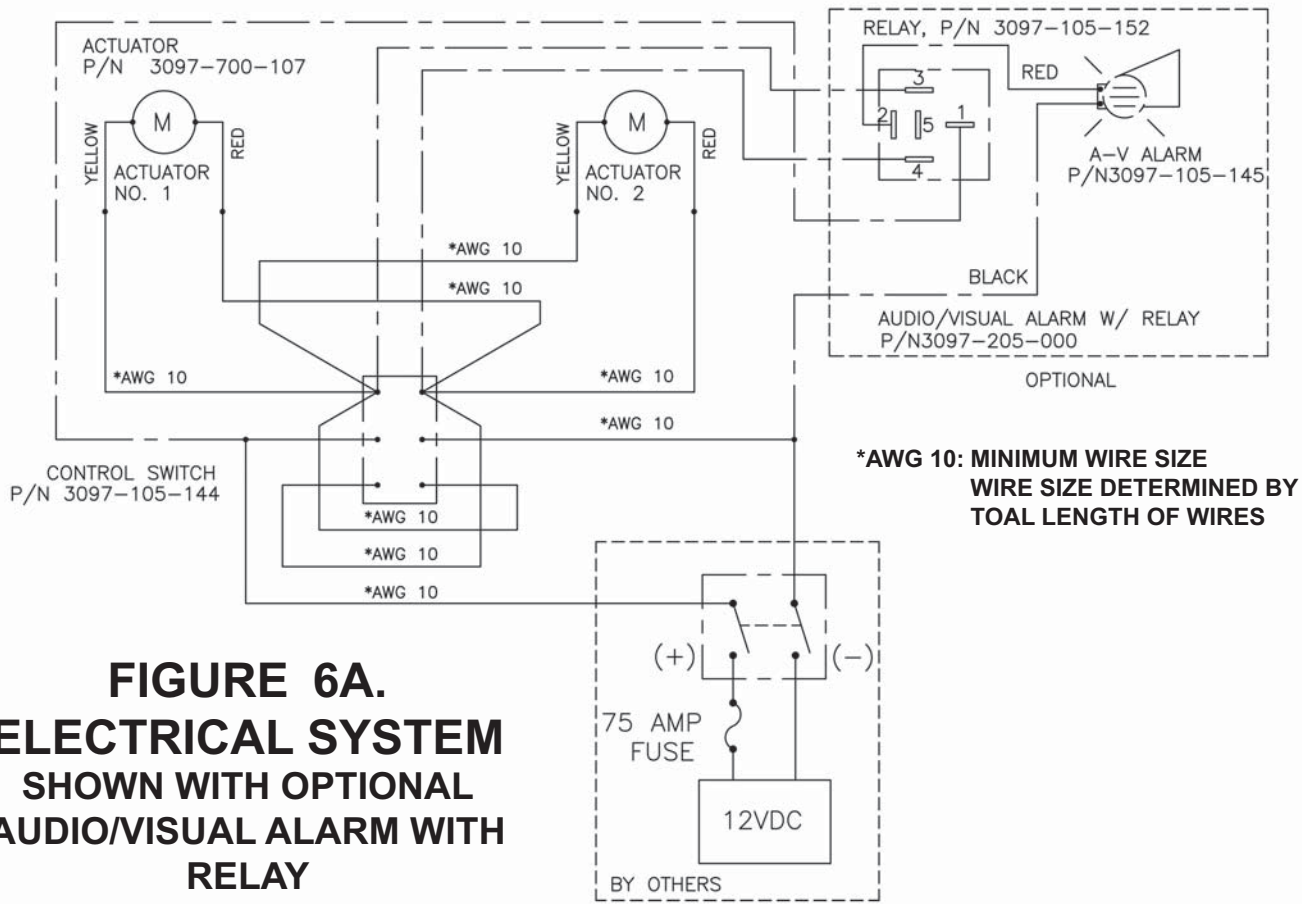




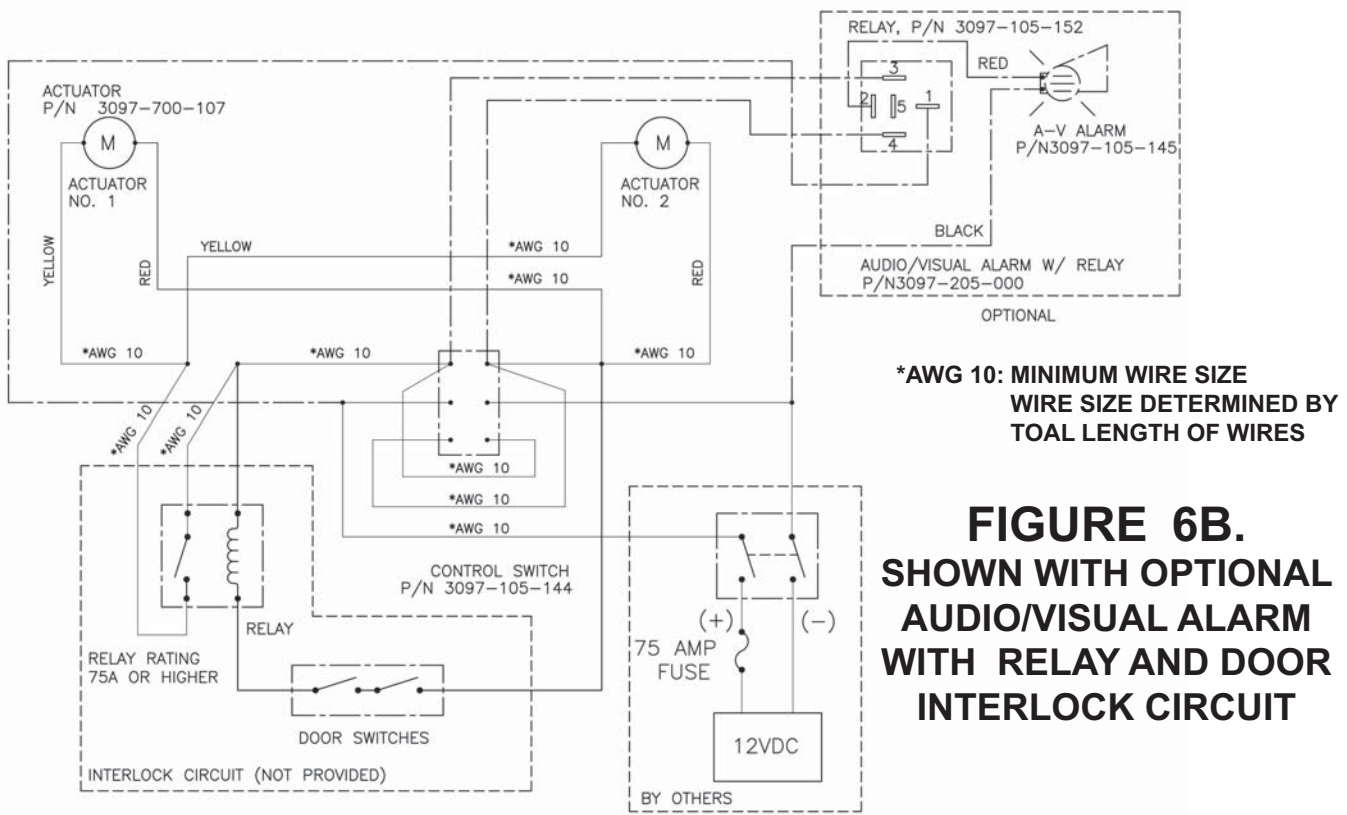
**FIGURE 4. SIDE VIEW MODEL LAS-HA-\_\_\_\_\_**



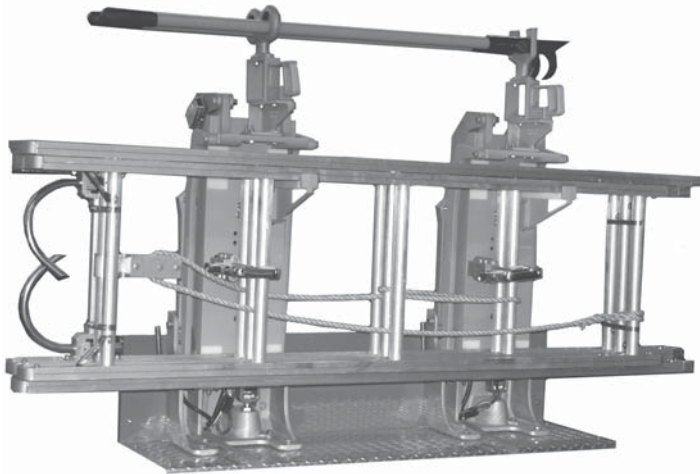
**FIGURE 5. COMMON INSTALLATION USING STIFFENING/BACKING PLATE**



**FIGURE 6A.**  
**ELECTRICAL SYSTEM**  
**SHOWN WITH OPTIONAL**  
**AUDIO/VISUAL ALARM WITH**  
**RELAY**

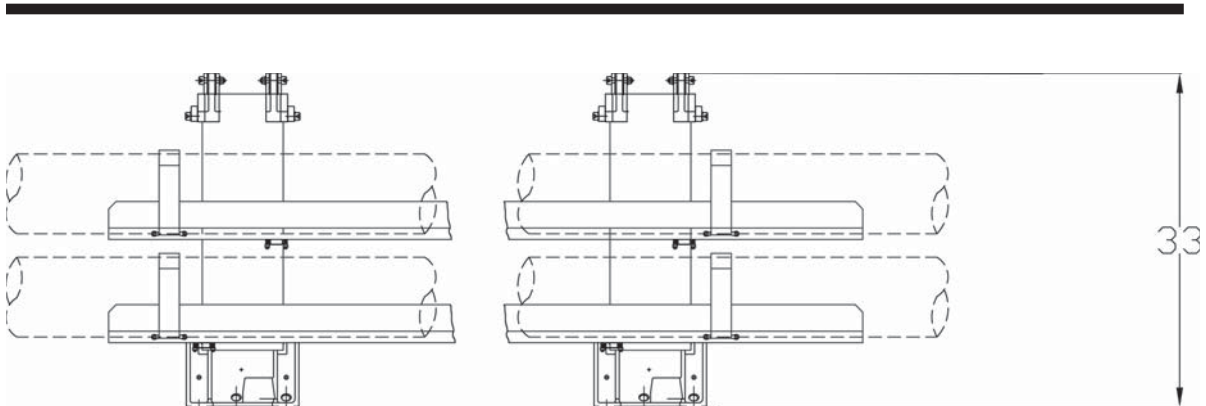
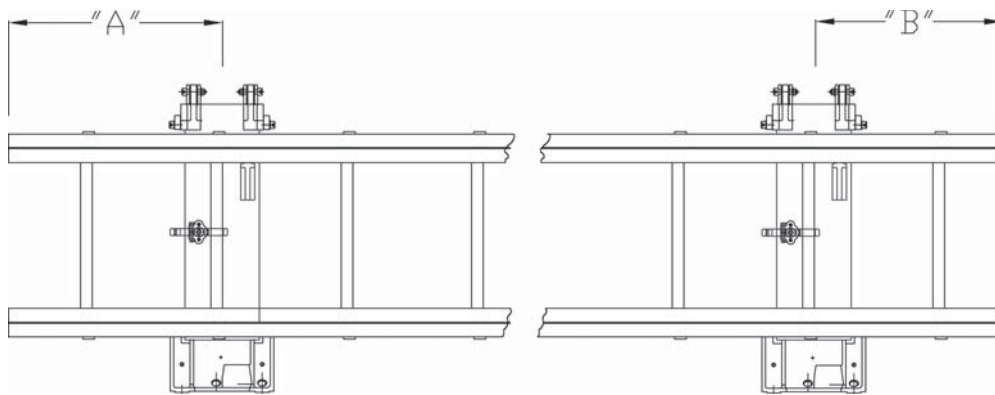


**FIGURE 6B.**  
**SHOWN WITH OPTIONAL**  
**AUDIO/VISUAL ALARM**  
**WITH RELAY AND DOOR**  
**INTERLOCK CIRCUIT**

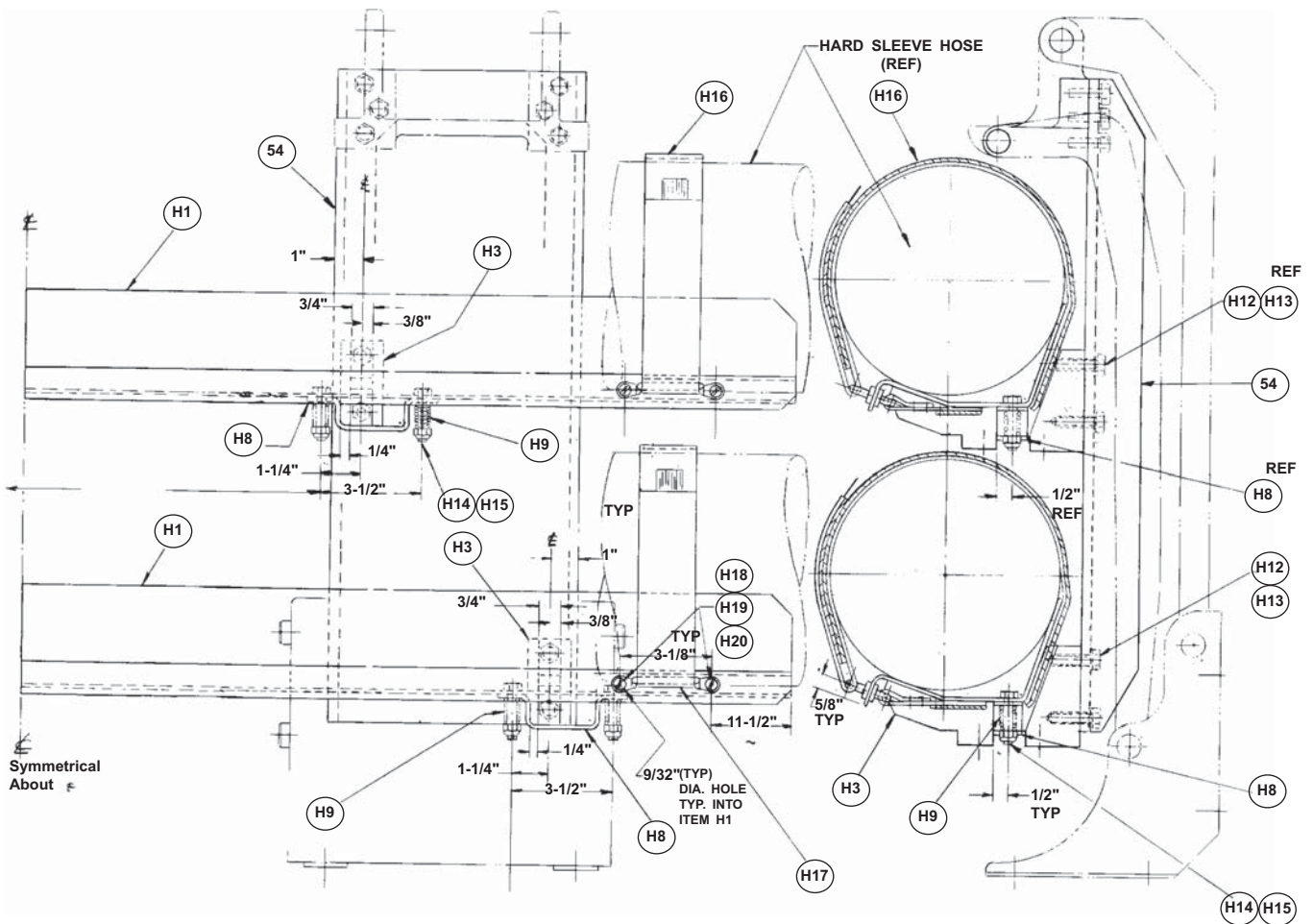


**FIGURE 7.  
FRONT VIEW OF  
LAS SYSTEM**

**NOTE EQUAL NUMBER OF  
RUNGS TO LEFT (A) AND  
RIGHT (B) OF DEVICE**



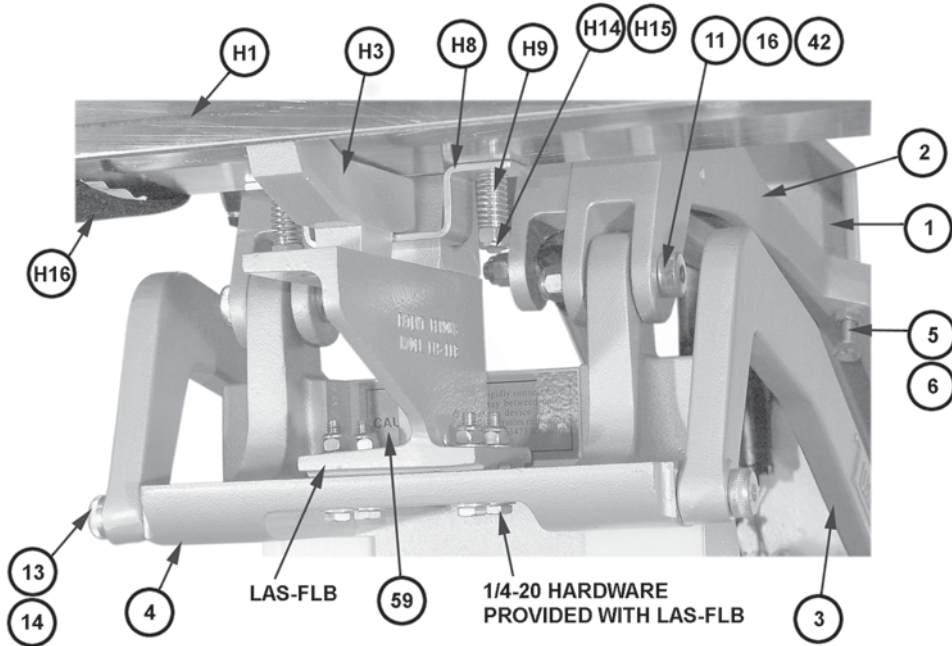
**FIGURE 8. FRONTAL VIEW OF HSS SYSTEM**



**FIGURE 9. MODEL HSS-\_\_\_ HARD SLEEVE SYSTEM**

**CHART 3. MODEL HSS-\_\_\_ PARTS LIST**

ITEM	PART NUMBER	DESCRIPTION	HSS-200	HSS-CWT-210
H1	3097-155-101	Hose Tray, 112" Long	-	2
H3	3097-150-103	Hose Tray Support Casting	2	2
54	3097-105-154	Channel Support 8" W x 25-1/4" L	1	1
H8	3097-150-108	Hose Tray Retainer	2	2
H9	3090-000-120	Compression Spring	4	4
H12	9010-103722	Hex Head Bolt, 3/8-16 x 1-3/8"	4	4
H13	9014-203700	Lock Washer, 3/8 I.D.	4	4
H14	9110-103124	Hex Head Bolt, 5/16-18 x 1-1/2"	4	4
H15	9113-103100	Hex Head Lock Nut, 5/16-18	4	4
H16	3099-738-000	Utility Mounting Strap # UMVS-1625-10	-	2
H17	3099-000-113	Footman's Loop, 2" # CPFL000003	-	4
H18	9010-232512	Round Head Screw, 1/4-20 x 3/4"	-	4
H19	9014-205500	Lock Washer, 1/4" I.D.	-	4
H20	9012-102500	Hex Head Nut, 1/4-20	-	4

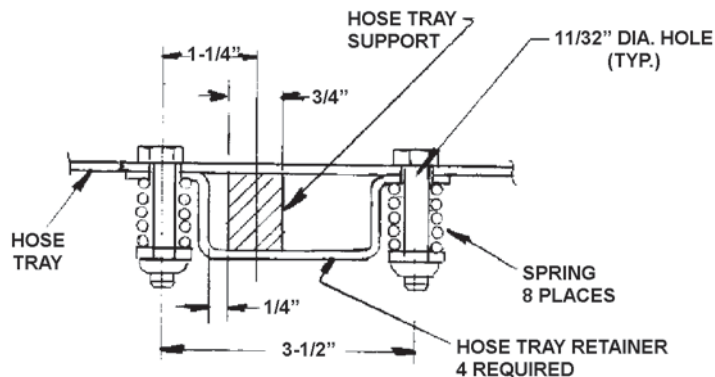
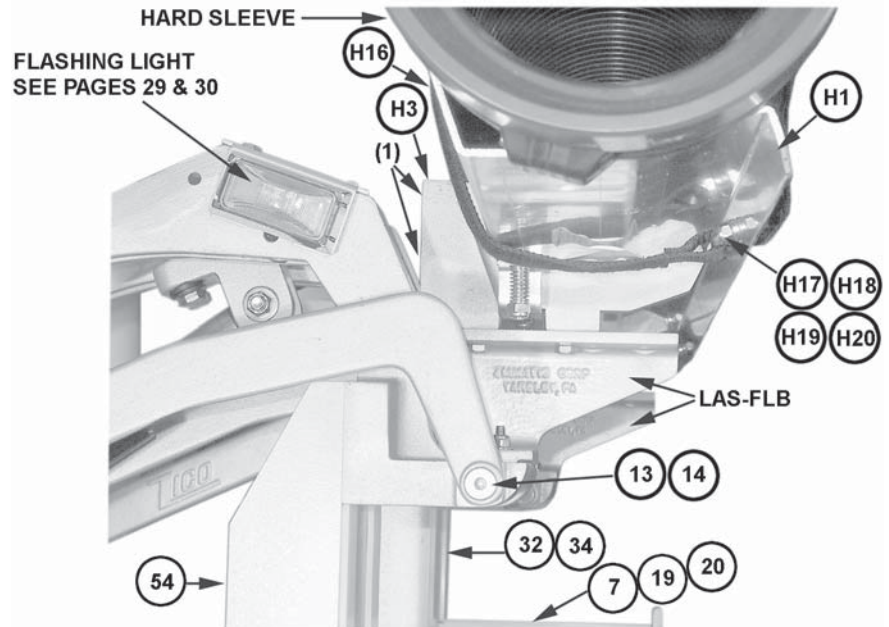


**FIGURE 10.  
HARD SLEEVE  
TRAY  
MOUNTED  
ON LAS-\_\_\_  
SYSTEM.  
REQUIRES  
LAS-FLB SET**

(1) H12 AND H13 WOULD BOLT THROUGH CHANNEL (54) AND INTO HOSE RAY SUPPORT CASTING (H3) ON THE HSS-\_\_\_ SYSTEM.

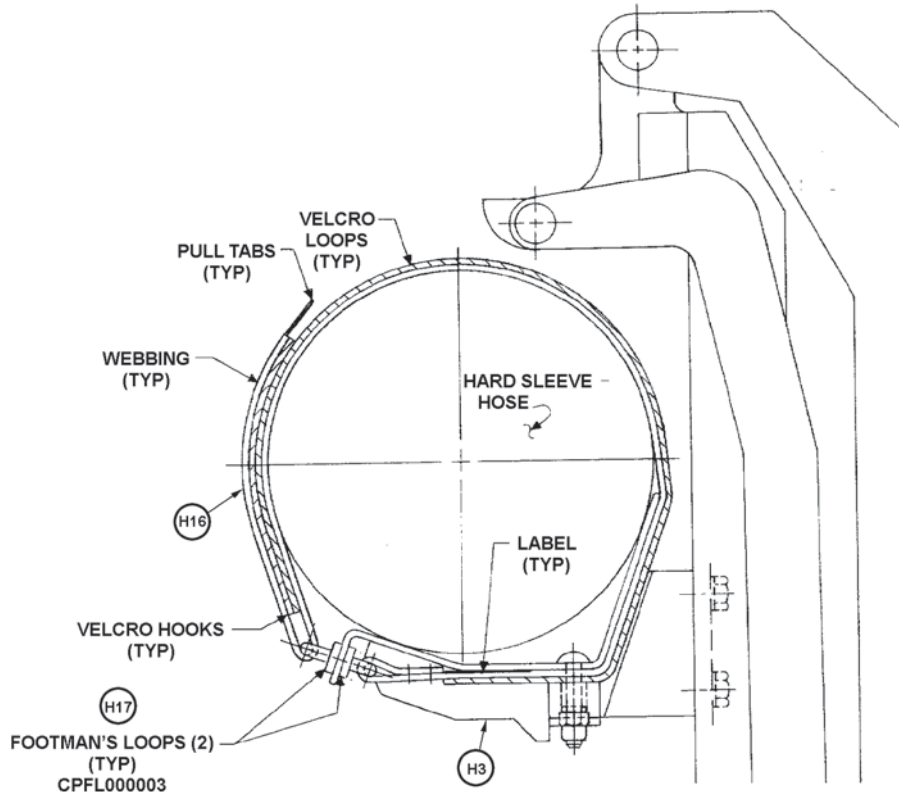
HSS-TMC INCLUDES: H3, H12, H13, H14 AND H15

HSS-TMH INCLUDES: H8, H9, H14, H15, H16, H17, H18, H19 AND H20

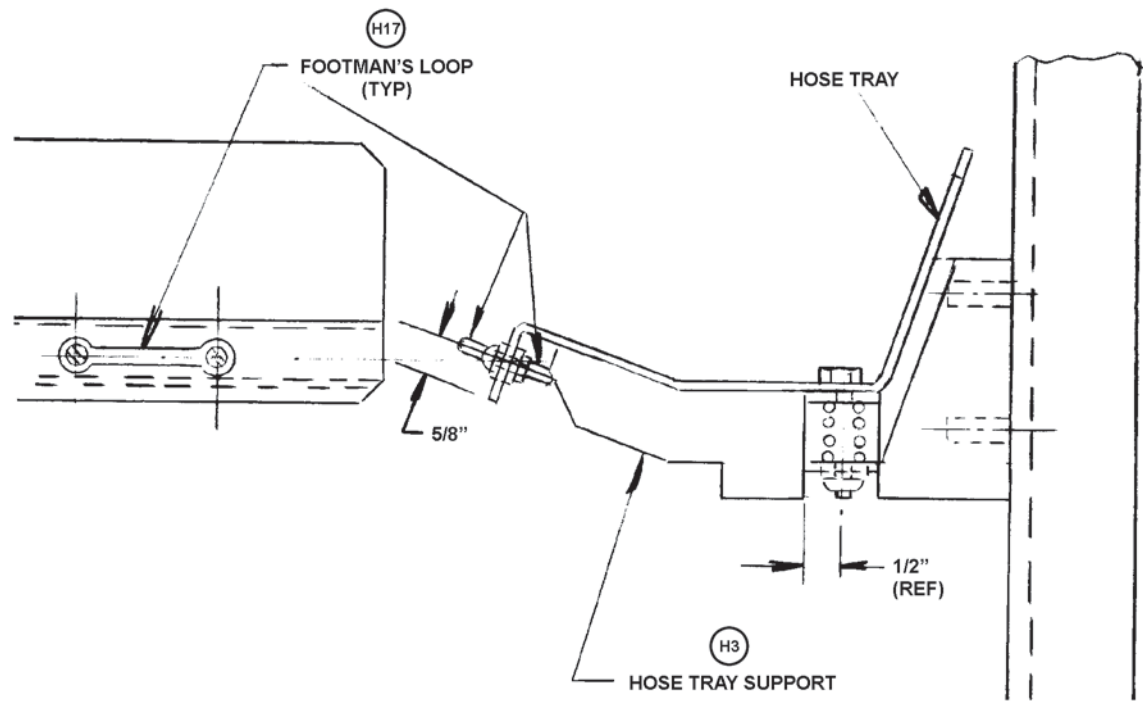


**DETAIL "A" SCALE 1/2**

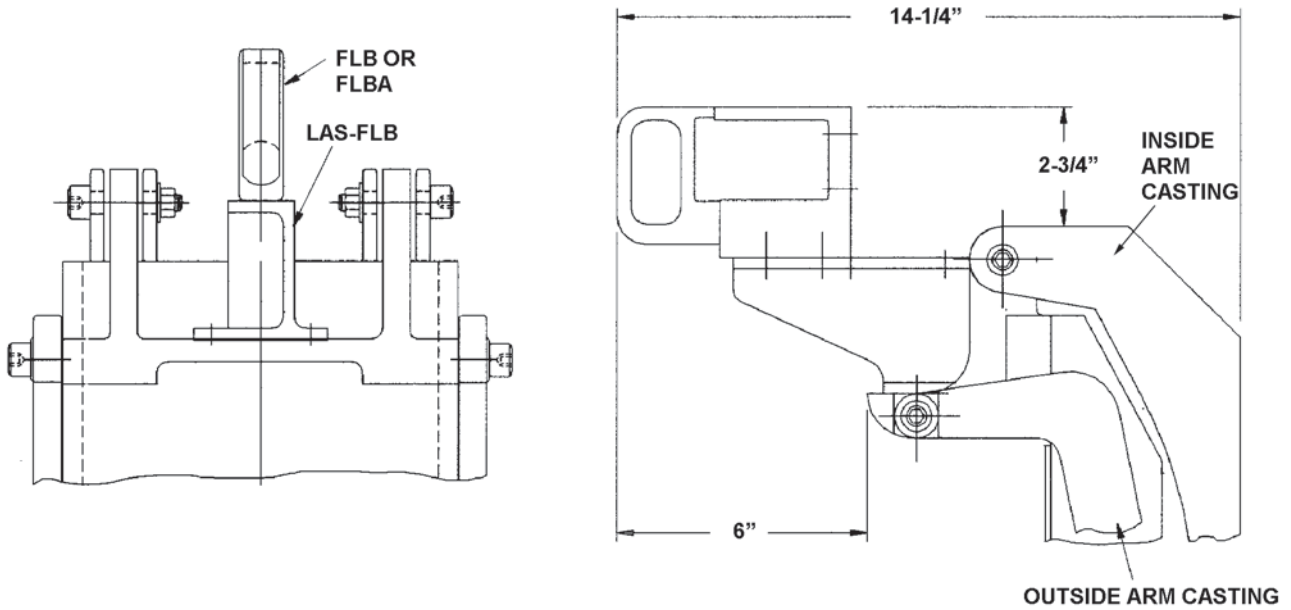
**FIGURE 11.  
HARD SLEEVE  
SYSTEM LOCATION AND  
DRILLING INSTRUCTIONS**



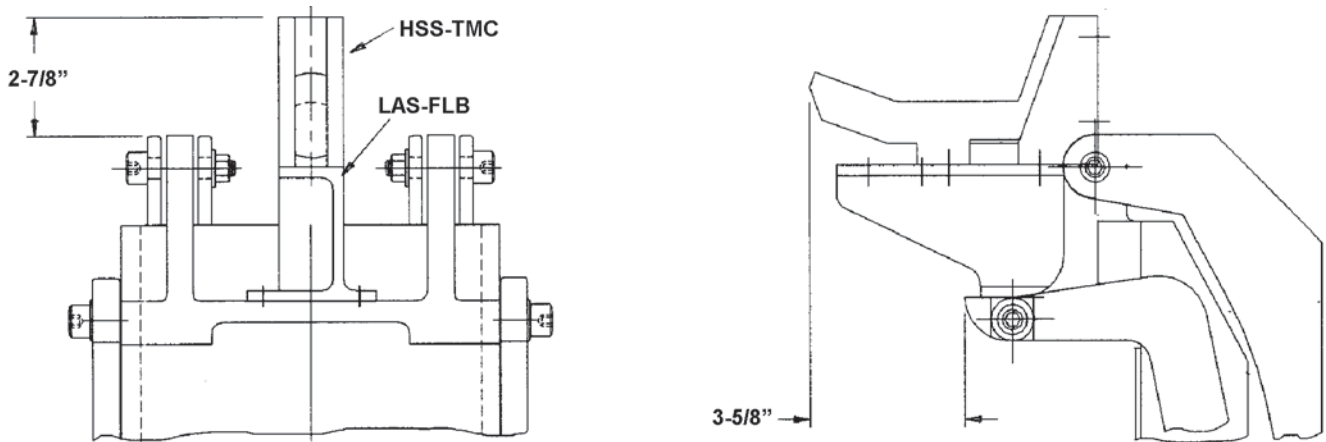
**FIGURE 12. QUIC-STRAP SYSTEM TO RETAIN HARD SLEEVE**



**FIGURE 13. HOSE TRAY SUPPORT WITH HOSE TRAY**

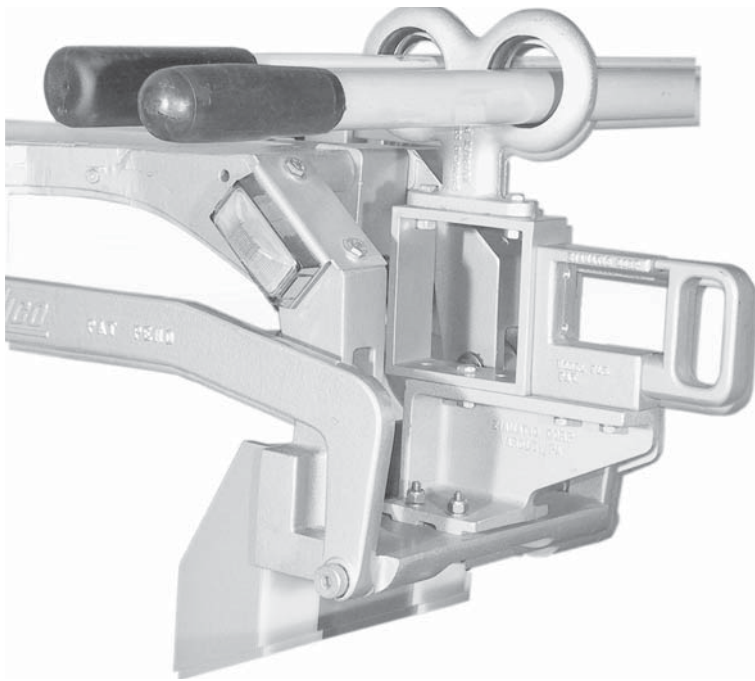


**FIGURE 14. MODEL LAS-FLB CASTINGS ATTACHED TO PIVOT SUPPORT CASTING (3097-105-104) WITH MODEL FLB OR FLBA FOLDING LADDER BRACKET CASTING FOR FOLDING ATTIC LADDER**

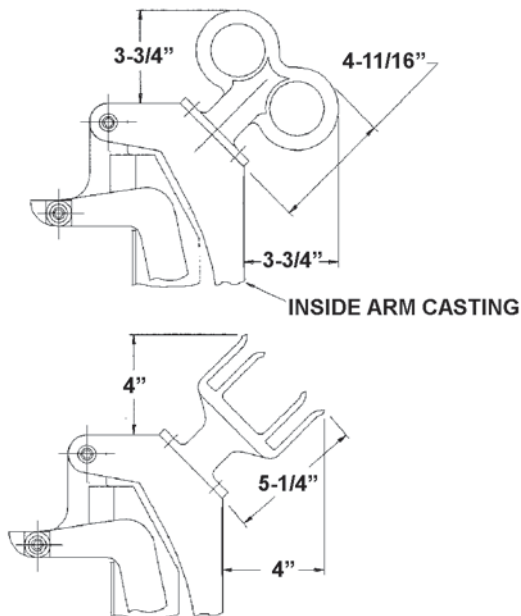
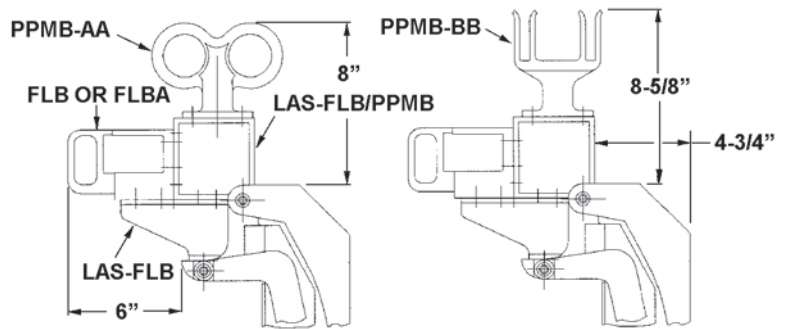


**FIGURE 15. MODEL LAS-FLB ATTACHED TO PIVOT SUPPORT CASTING (3097-105-104) WITH MODEL HSS-TMC TRAY MOUNT CASTING FOR MOUNTING OF HARD SLEEVE**

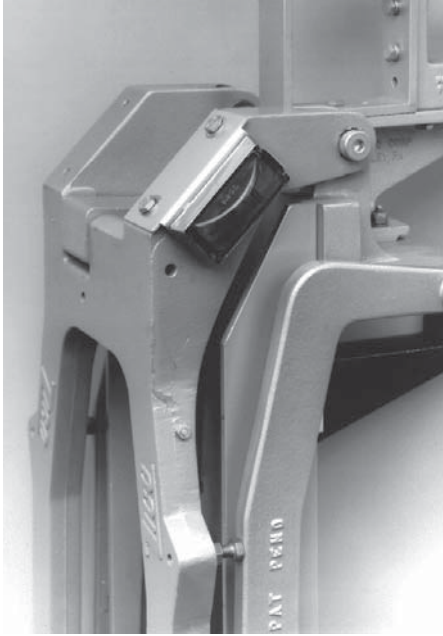




**FIGURE 16.  
MODEL LAS-FLB/PPMB  
EXTRUSION ADDED TO  
SUPPORT PPMB-AA  
(DOUBLE RING) OR  
PPMB-BB (DOUBLE FORK)  
PIKE POLE MOUNTING  
BRACKET**



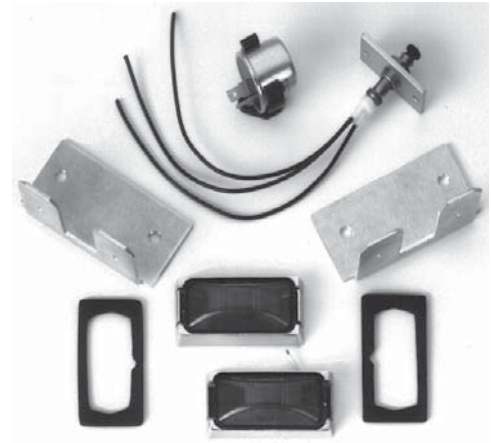
**FIGURE 17.  
MODEL PPMB-AA (DOUBLE RING)  
OR PPMB-BB (DOUBLE FORK)  
PIKE POLE MOUNTING BRACKETS  
MAY BE ATTACHED DIRECTLY TO THE  
INSIDE ARM CASTING (3097-700-103)**



NFPA 1901-96 Standard requires flashing lights be provided, facing front and rear of apparatus. Lights must continue to flash while the device is out of the stored position.

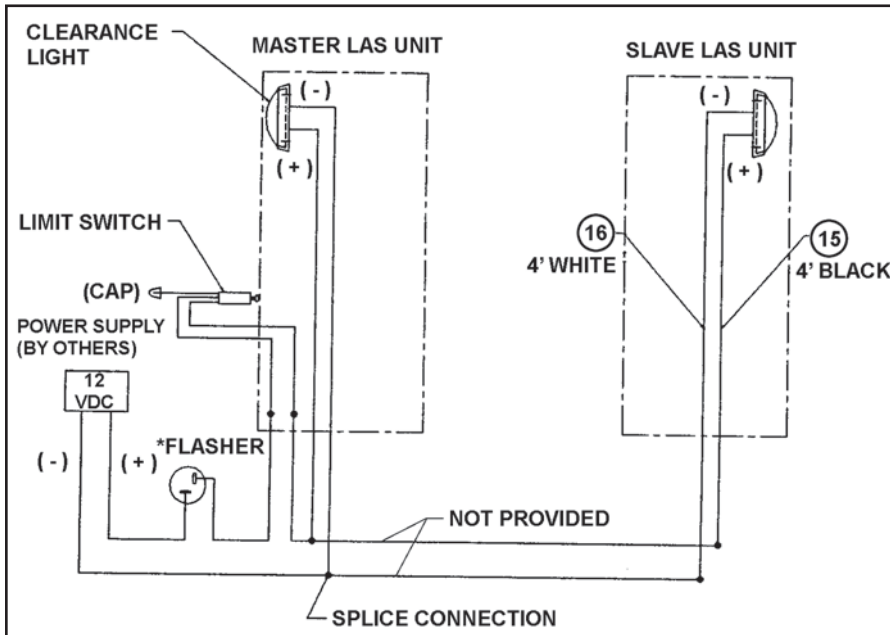
All systems are provided with flashing lights. The audio/visual alarm will continue to be offered as an option (see Section 8000 for the audio/visual alarm).

Drilled and tapped holes will be provided on QUIC-LIFT Systems shipped to mount the light kits.



**LIGHT KIT COMPONENTS**

MODEL NUMBER	PART NUMBER	DESCRIPTION	WT./KIT IN LBS.
LAS-HA-FLK	3097-720-000	Flashing Light Kit	1.0



**FIGURE 18. FLASHING LIGHT KIT MODEL LAS-HA-FLK**

**Wiring System:**

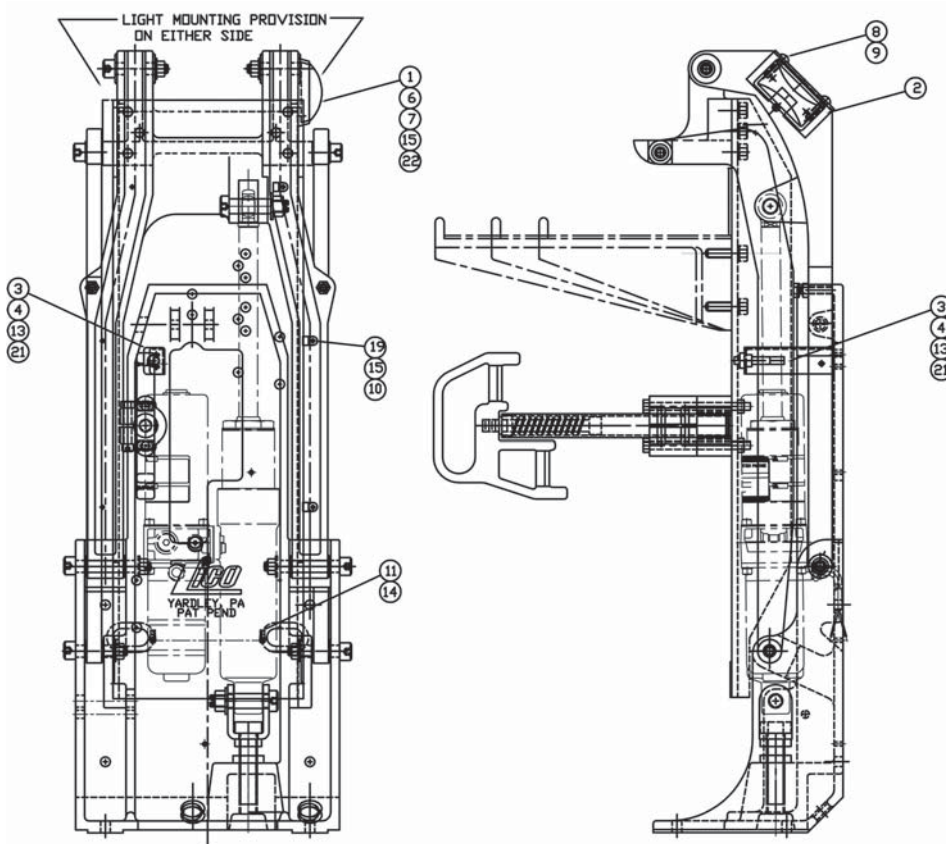
1. One 2-conductor gray cable (item 15) is provided for each light (item 1).
2. In-line splices (item 12) are provided. Seventh splice to be connected to third wire in the limit switch (item 3). This wire may be used for indicator light in the cab.
3. Flasher (item 5) should be mounted in a weather-proof location and mounted in the clip (item 17) provided.
4. Figure 20, page 28 gives a recommendation for routing wires for accessories through base casting.

ITEM NO.	PART NUMBER	DESCRIPTION	QTY.
1	3097-270-101	Clearance Light	2
2	3097-270-103	Bracket, Light Mount	2
3	3097-270-105	Switch, Limit	1
4	3097-720-101	Bracket, Limit Sw.	1
5	3097-270-109	Flasher	1
6	9110-151108	Screw, Sheet Metal, #4 x 1/2 Oval Hd Phil., SS	4
8	9010-102510	Screw, HH 1/4-20 x 5/8 M/S SZP	4
9	9014-202500	Lockwasher, 1/4 Nom.	4
10	3030-140-165	Nylon Tree Rivet, $\phi$ 3/16, 0.680" Lg.	6
11	3097-720-103	Cable Tie, 8.5" Lg. #10 Mtg Hole, Nylon	2
12	3097-270-113	In Line Splice	7
13	9010-222006	Screw, #10-32 x 3/8, Pan Hd Phillips, SZP	2
14	9025-132008	Screw, #10-32 x 1/2, Self Tap, Pan Hd Phil, SZP	2
15	3097-510-110	Gray 2 Cond Cable, 16 Ga Lead Wire, 4 Ft.	2
17	3075-175-105	Delrin Tool Clip	1
18	3097-270-121	Female Push-On Term., (Use with Item 5)	2
19	3097-720-105	Nylon Cable Clamp, $\phi$ 3/16 I.D., #10 Mtg Hole	6
21	3097-720-107	Cable Tie, 5.5" Lg. 0.13" Wide, Nylon	1
22	3097-270-115	Bullet Connector, .156", 16-14 Ga. Wire	4

#### CHART 4. PARTS LISTING FOR MODEL LAS-HA-FLK

Please make sure all parts are accounted for prior to beginning installation.

The limit switch plate (item 4) has been pre-mounted onto one of the base castings using two #10-32 x 3/8, pan hd screw (item 13).

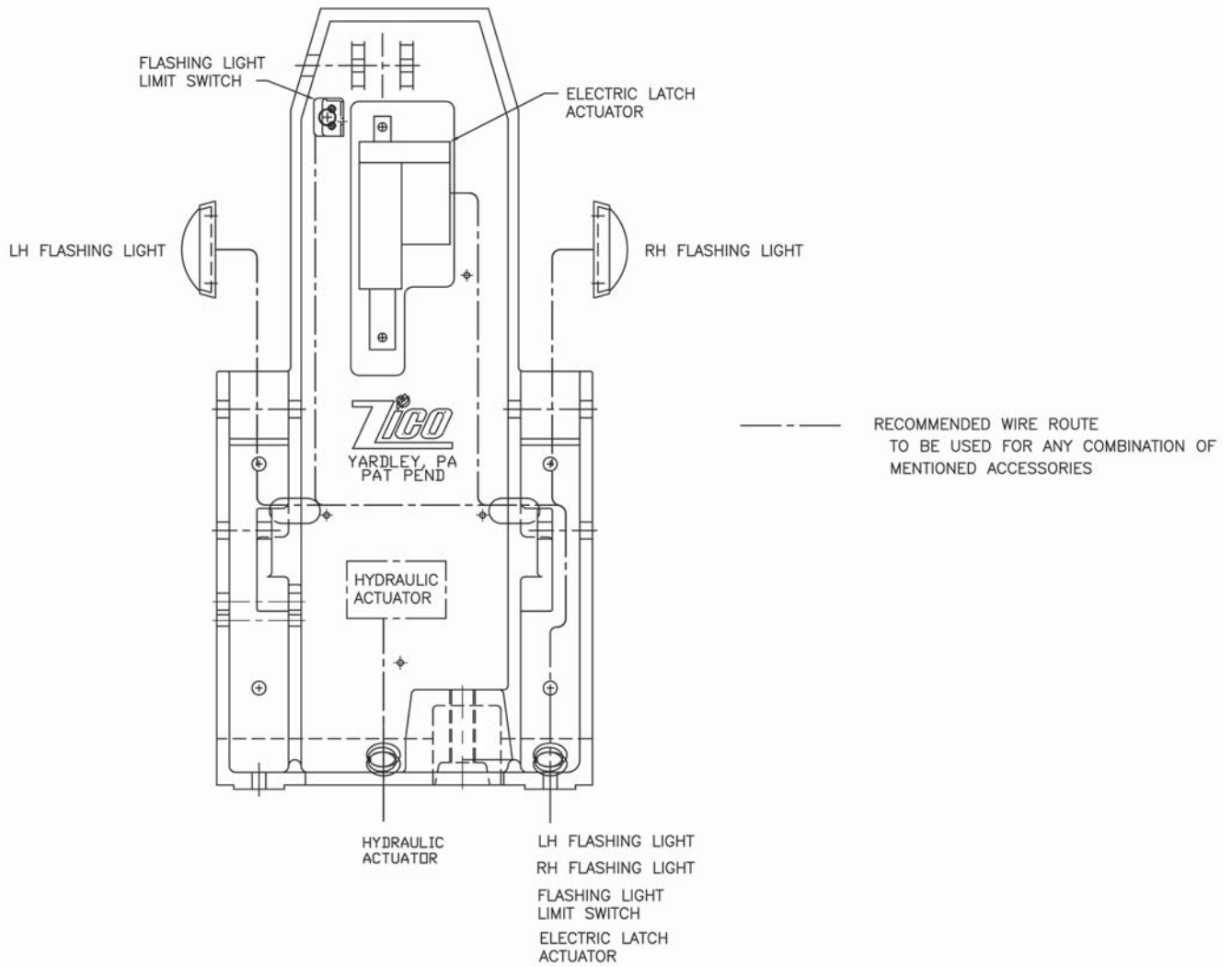


Lights are to be mounted on the outboard side on each set of LAS units.

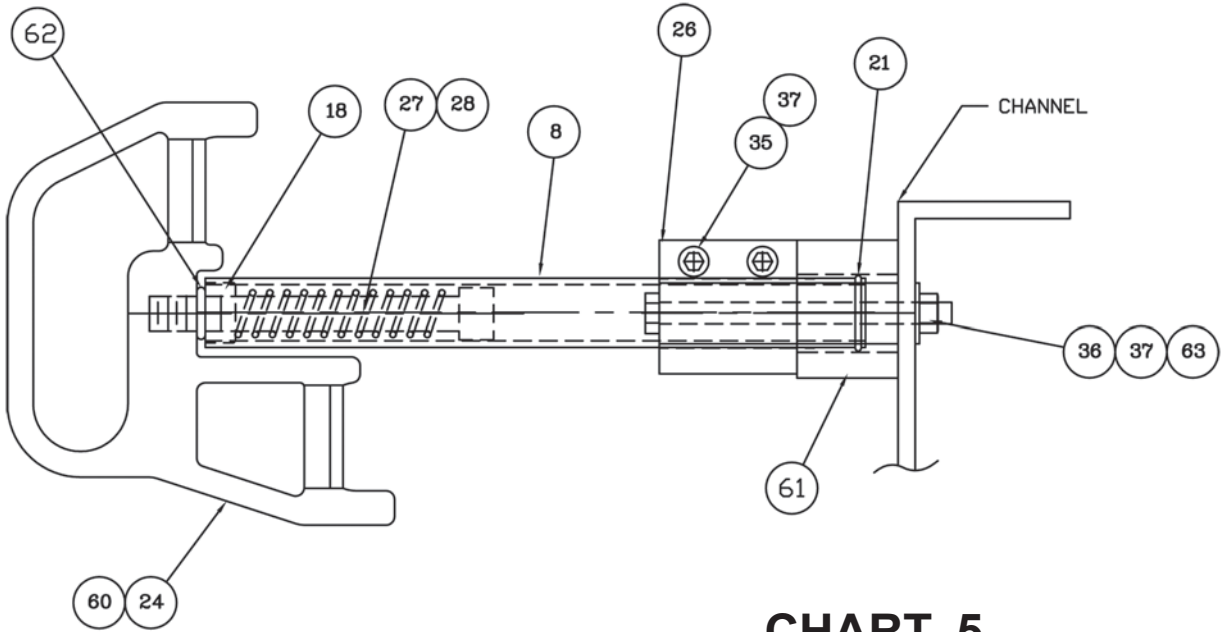
Limit switch (item 3) makes contact with the inside of channel to shut off the lights.

\*Reflective tape is attached to each ladder mount casting in compliance with NFPA 1901-96.

**FIGURE 19. FLASHING LIGHT KIT  
MODEL LAS-HA-FLK**



**FIGURE 20.  
ACCESSORY WIRING**

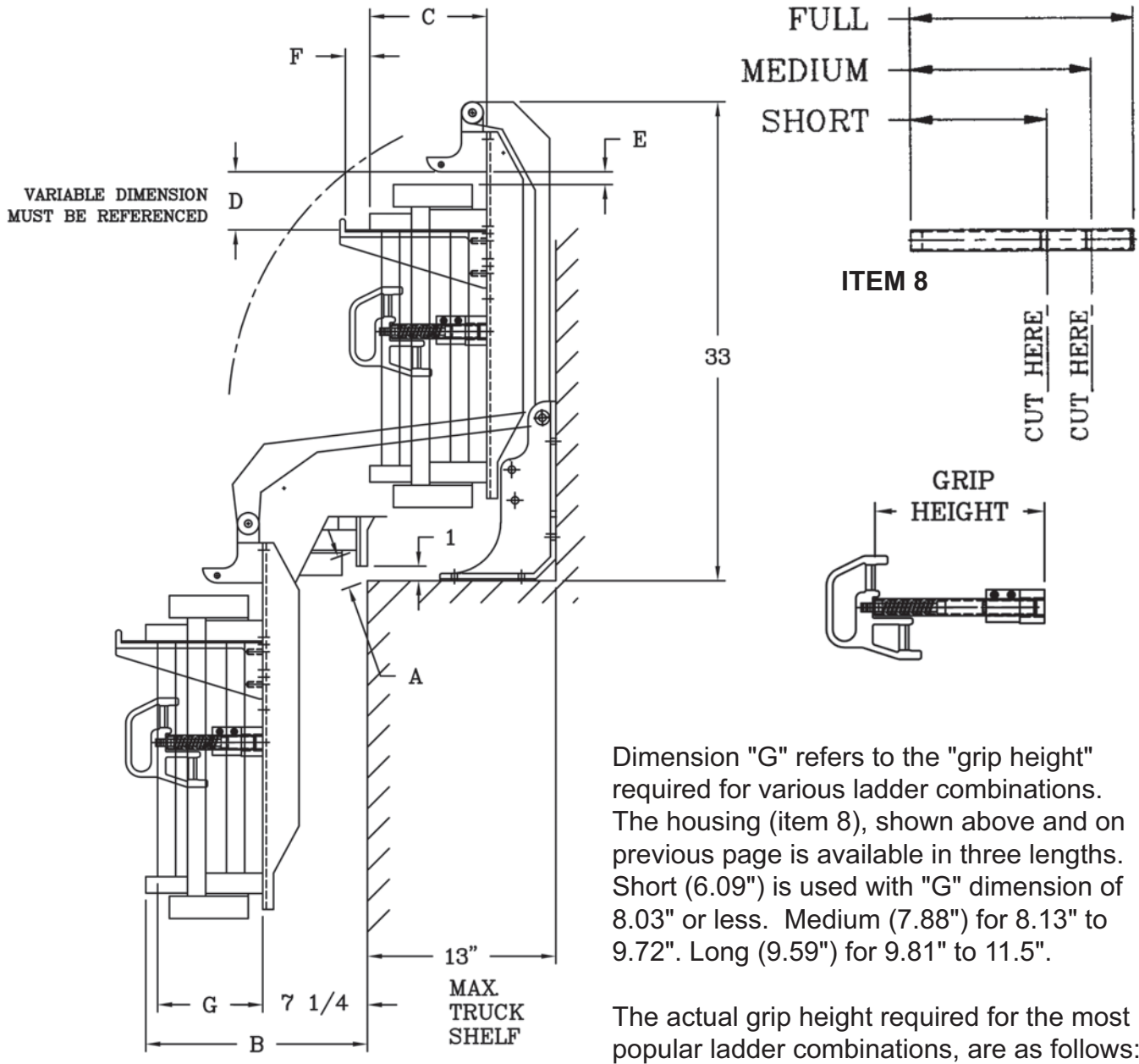


**CHART 5  
PARTS LISTING FOR  
LAS-HA HANDLE ASSEMBLY**

Order 3097-705-910 to receive one complete handle assembly for LAS-HA-775. For LAS-HA-975 order 3097-710-910 and for LAS-HA-1200 order 3097-715-910. Two handles are required per system.

ITEM	PART NAME	PART NO.	QTY.
8	Housing, Short	3097-700-115	1
	Housing, Medium	3097-700-117	1
	Housing, Long	3097-700-119	1
18	Secscrew - 7/8-14 Hollow Lock	3097-105-118	1
21	Retaining Ring	3097-700-121	1
24	Handle	3097-700-123	1
26	Support, Retainer Handle	3097-105-126	1
27	Screw 1/2-13 x 4 1/2 Socket Hd	9010-335072	1
28	Spring	3097-700-125	1
35	Screw, 5/16-18 x 2 Socket Hd, SZP	9010-333132	2
36	Screw, 5/16-18 x 4 1/4 Hex Hd., SS	9110-103168	2
37	Hex Nut, 5/16-18 Self Lock	9013-133100	4
60	Wear Strip, 1-1/2" Lg.	3097-700-127	2
61	Spacer	3097-700-129	1
62	O-Ring, EPDM, $\phi$ 1/8 C/S, 1/2" ID	3097-700-131	1
63	Washer, $\phi$ 5/16 Regular SZP	9014-113100	2

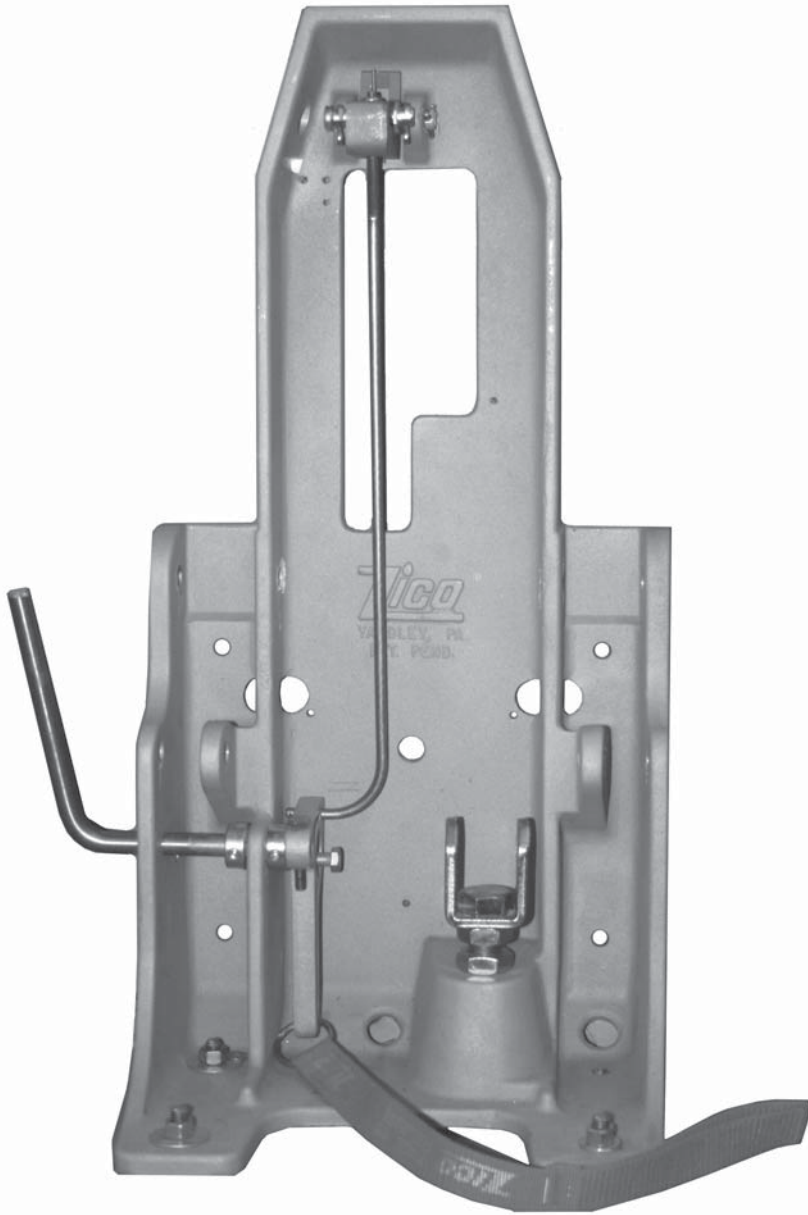
**FIGURE 21.  
HANDLE ASSEMBLY FOR LAS-HA SYSTEMS**



Short (6.09") 8.03" or less  
 Medium (7.88") 8.13" - 9.72"  
 Long (9.59") 9.81" - 11.5"

<u>COMB. NO.</u>	<u>GRIP HEIGHT</u>	<u>LENGTH TUBE</u>
10	6.00"	Short
55	8.00"	Medium
64	8.75"	Medium
95	6.25"	Short
149	9.50"	Long

**FIGURE 22.**  
**HANDLE ASSEMBLY FOR LAS-HA SYSTEMS**



QUIC-LIFT™ Ladder Access System is available with either a manual or electric locking system. This page covers the manual system.

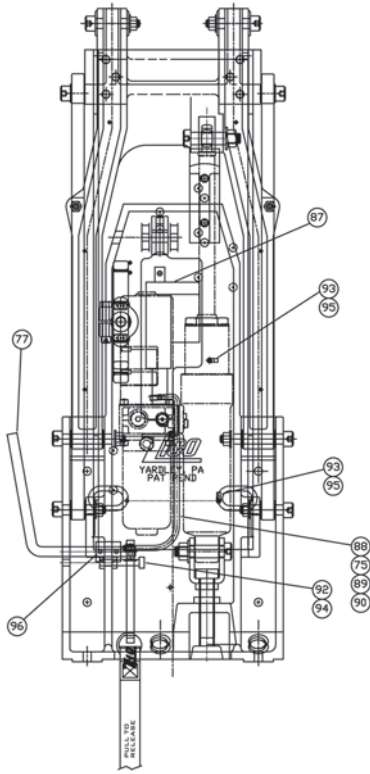
The manual locking system provides a positive means of retaining the ladders. The lock must be de-activated prior to operating the electrical control. This is done by pulling outward on the strap (99) or pushing back on the handle (77).

Parts list provided on pages 32 and 33.

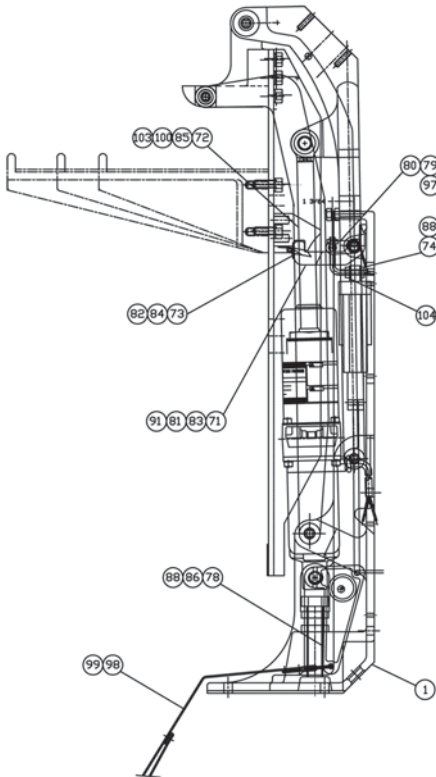
**Model LLAS-HA-MLS shown for use with  
Model LAS-HA Systems**

**FIGURE 23.  
MANUAL LOCKING SYSTEM**

## CHART 6 PARTS LISTING MANUAL & ELECTRIC LOCKING SYSTEMS

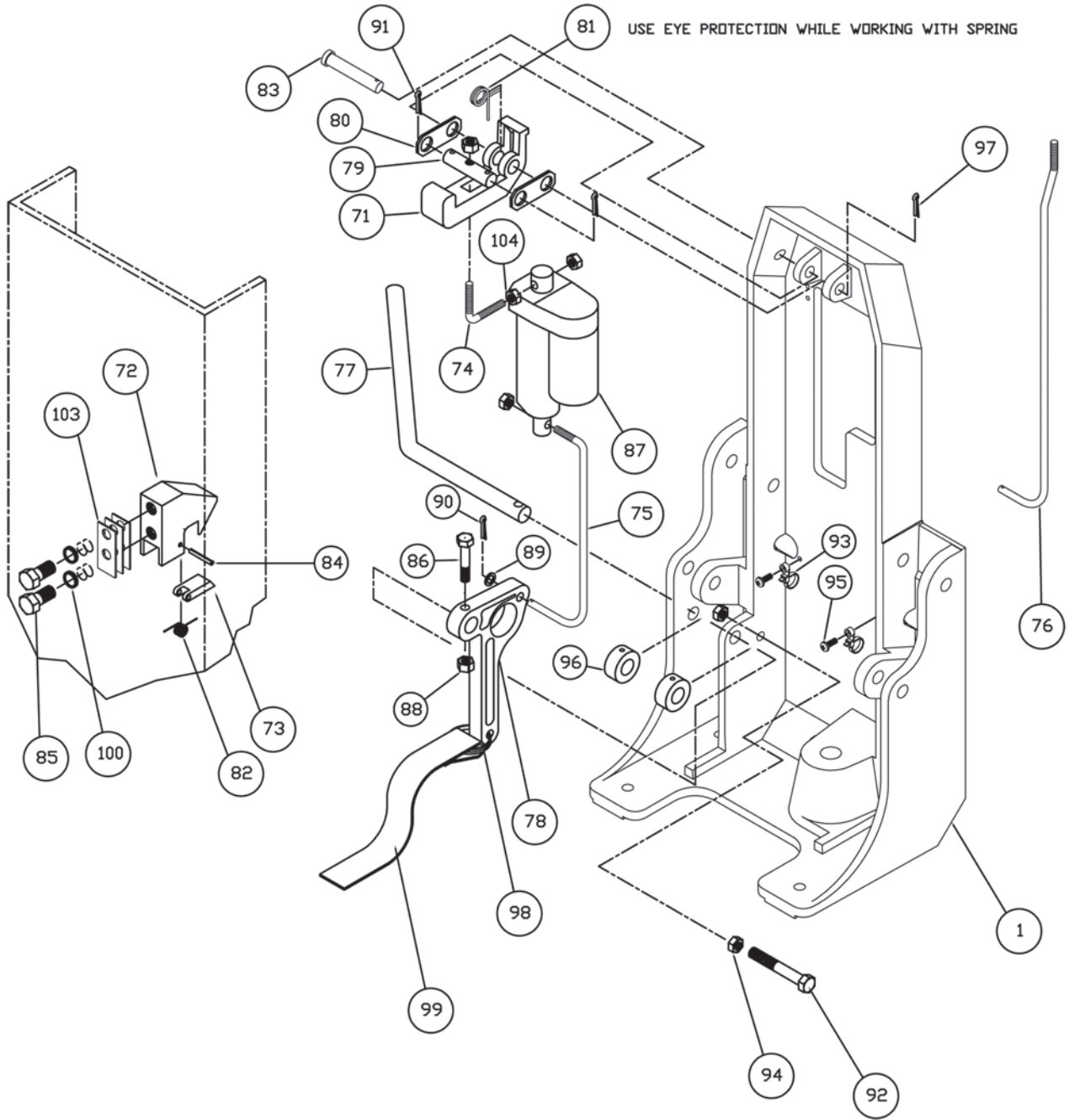


**FIGURE 23.  
LOCKING SYSTEM  
COMPONENTS**



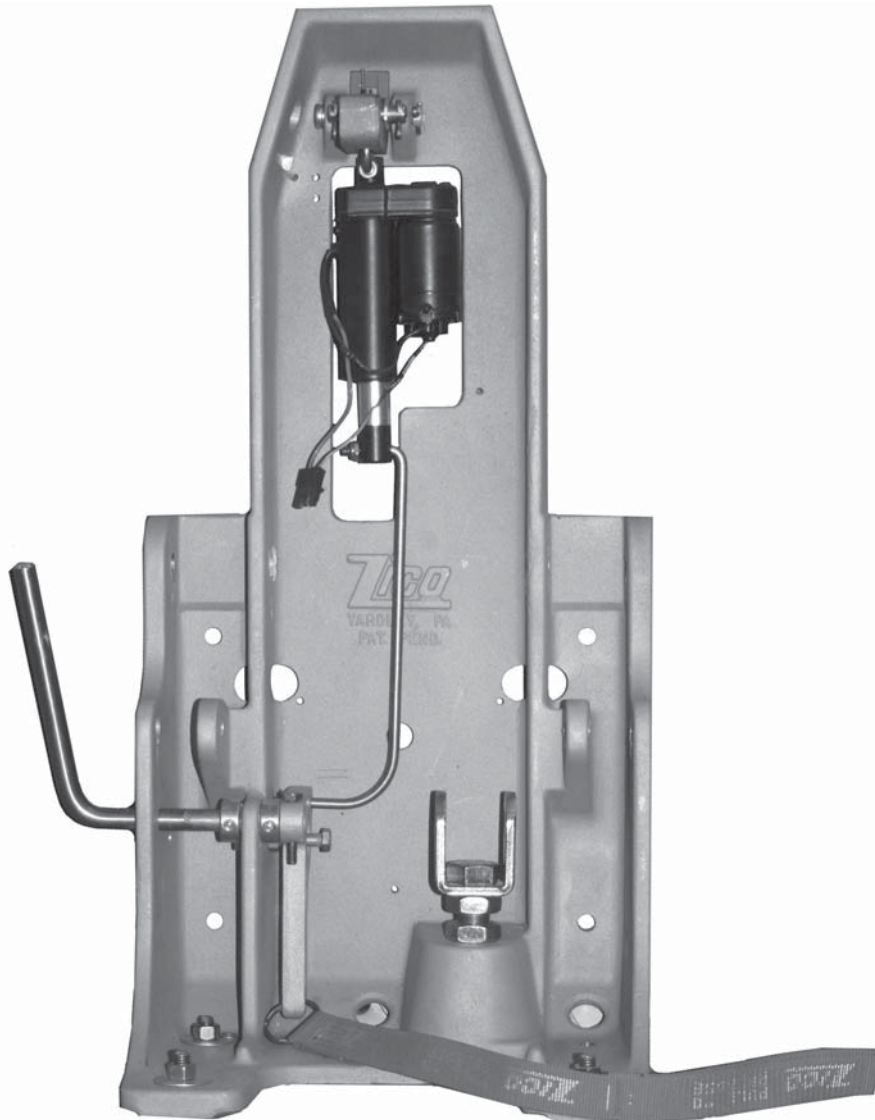
ITEM	PART NO.	DESCRIPTION	MECHANICAL	
			ELEC/MECH	QTY.
1	3097-700-101	Base Casting for LAS-HA	1	1
61	3097-280-103	Latch	1	1
62	3097-280-105	Hook	1	1
73	3097-280-107	Keeper, Latch	1	1
74	3097-725-103	Rod, Upper	1	-
75	3097-725-105	Rod, Lower	1	-
76	3097-725-107	Rod, Manual (Not Shown)	-	1
77	3097-280-115	Handle	1	1
78	3097-280-117	Crank Arm	1	1
79	3097-280-119	Pin, Link	1	1
80	3097-280-121	Link Plate	2	2
81	3097-725-111	Spring, Latch	1	1
82	3097-280-125	Spring, Keeper	1	1
83	9080-004336	Pin, Clevis $\phi 7/16$ x 2-1/4 SZP	1	1
84	9040-101214	Pin, Spring Lock $\phi 1/8$ x 7/8	1	1
85	9110-103712	Screw, HH 3/8-16 x 3/4, SS	2	2
86	9110-102524	Screw, HH 1/4-20 x 1-1/2", SS	1	1
87	3097-285-135	Actuator	1	-
88	9113-172501	Nut, Self Lock 1/4-20 Hex SS, Low Profile	4	2
89	9114-112500	$\phi 1/4$ Plain Washer, SS	1	1
90	9070-000608	Pin, Cotter, $\phi 1/16$ x 1/2	1	1
91	9070-000912	Pin, Cotter, $\phi 3/32$ x 3/4	2	2
92	9110-103132	Screw, HH $\phi 5/16$ -18 x 2, SS	1	1
93	3097-720-103	Cable Tie, 8.5" Lg. #10 Mtg Hole, Nylon	2	-
94	9113-103100	Hex Nut, 5/16-18, SS	2	2
95	9025-132008	Screw, 10-32 x 1/2, Selftap, Pan, Phil, SZP	2	-
96	3097-280-127	$\phi 1/2$ Shaft Collar, SZP	2	2
97	9070-001216	Pin, Cotter, $\phi 1/8$ x 1	1	1
98	0000-000-120	1" Ring, Key	1	1
99	3097-280-129	Pull Strap	1	1
100	9114-203700	$\phi 3/8$ Split Lockwasher, SS	2	2
101	3097-285-200	Control Panel Assy.	1	-
103	3097-725-113	Hook Spacer	3	3
104	9012-102500	Nut, 1/4-20, SZP	1	-





Use eye protection while working with spring (81)

**FIGURE 25.**  
**COMPONENT PARTS FOR MANUAL AND ELECTRIC**  
**LOCKING SYSTEMS - EXPLODED VIEW**



QUIC-LIFT™ Ladder Access System is available with either a manual or electric locking system. This page covers the electric system.

The electric locking system provides a positive means of retaining the ladders.

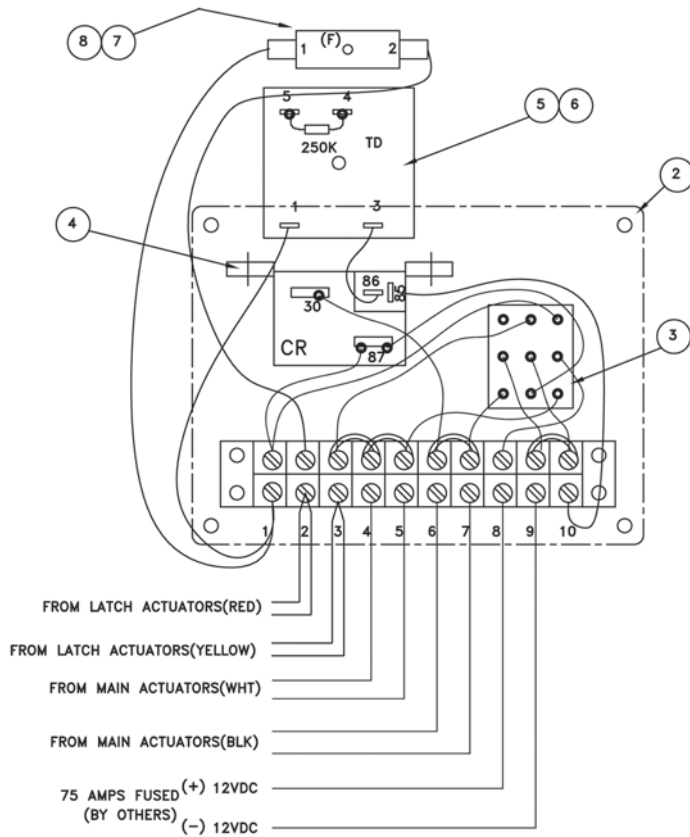
Parts list provided on pages 32 and 33. For wiring information see pages 36 and 37.

Figure 20, page 28 gives a recommendation for routing wires for accessories through base casting.

**Model LLAS-HA-ELS shown for use with Model LAS-HA Systems**

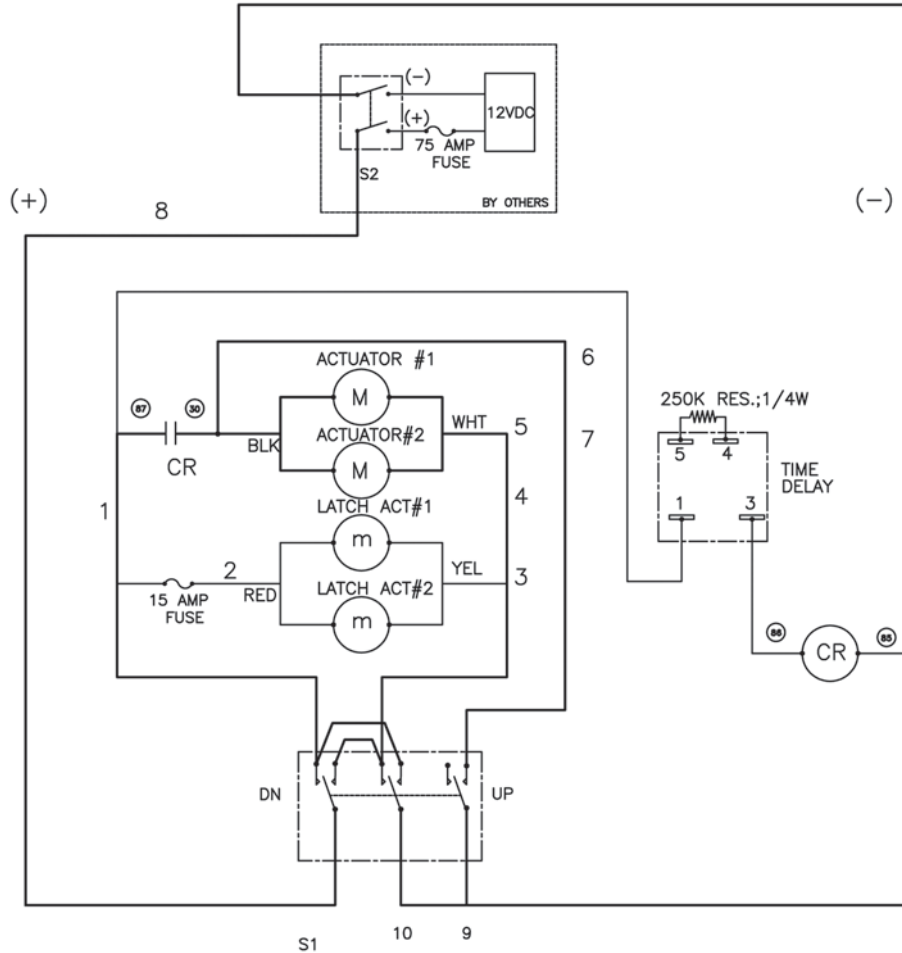
Press down on the operating switch and the small electric actuator opens the locking mechanism. After a momentary delay, the main electric actuator lowers the system.

**FIGURE 26.  
ELECTRIC LOCKING SYSTEM**



ITEM	DESCRIPTION	PART NO.	QTY.
1	Nameplate (Not Shown)	3097-285-113	1
2	Mounting Plate	3097-285-115	1
3	Switch, 3P2T Mom	3097-285-117	1
4	Relay	3097-285-119	1
5	Timer	3097-285-121	1
6	Resistor, 250K-Ohm; 1/4W	3097-285-123	1
7	Fuseholder	3097-285-125	1
8	Fuse, $\phi 1/4 \times 1-1/4$ , 15 Amp	3097-285-127	1
9	Sub-Plate	3097-285-129	1
10	Terminal Block, 10 Pos	3097-285-131	1
11	Jumper, Term	3097-285-133	4
12	Boot, Toggle Switch	3097-105-145	1

**FIGURE 27.**  
**WIRING PICTURAL FOR LLAS-HA-ELS ELECTRIC LOCKING SYSTEM**  
**SHOWING DOOR INTERLOCKS**



**FIGURE 28.  
WIRING SCHEMATIC FOR LLAS-HA-ELS ELECTRIC LOCKING SYSTEM  
SHOWING DOOR INTERLOCKS**

**Mode of Operation**

- Turn on power to LAS unit - S2 (by others)

**Down Mode**

- Actuate switch and hold in the down position - (S1).  
The latch actuator will start to unlock the latch.  
There will be a one (1) second delay after the latch actuator stops to ensure complete latch dis-engagement.  
Ladder will start to move down.  
At full down position release switch.

**Up Mode**

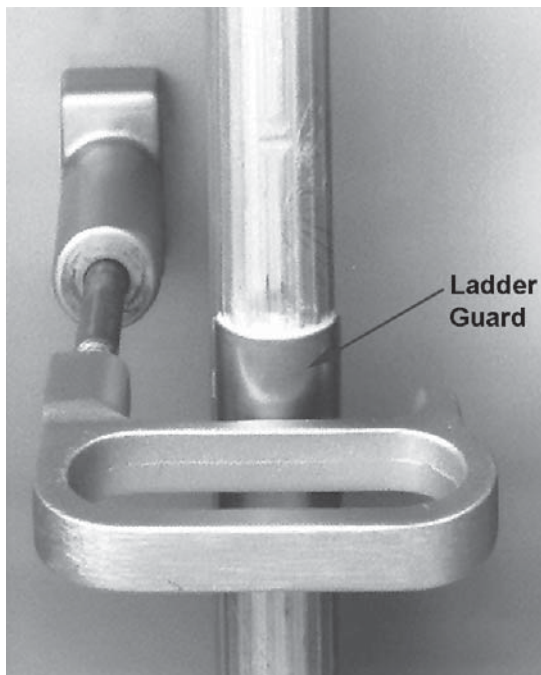
- Actuate switch and hold in the up position (S1).  
Both lock actuator and main actuators will extend simultaneously.  
Hold switch until both units have reached full up position.

In the event the small electric actuator fails to operate, the lock may be de-activated by pulling outward on the strap (99) or pushing back on the handle (77).

NOTE: Relay CR2 for door interlock must be rated 75A or higher.



Kit contains one tube of epoxy and two stainless steel rung protectors.



Rung protector installed showing proper placement. Old style handle assembly showing handle retainer casting.

#### Instructions for Use:

1. Clean rungs with mild soap and water. Let dry.
2. Mark mounting location on rung.
3. Follow instructions for mixing the epoxy.
4. Spread epoxy evenly on the inside of the two rung protectors.
5. Clamp the rung protectors onto the rungs, using light pressure.
6. Let dry for 24 hours.
7. Place back into service.

**NOTE:** Ladder manufacturer's have kits available to prevent wear of the rungs from contact with the ladder beams. We strongly suggest they be used to extend the life of your ladder.

**FIGURE 29.  
LADDER GUARD KIT  
MODEL LAS-LGK**

## CHART 7. LAS-HA PROBLEM SOLVING

### **PROBLEM:**

Units are running out of synchronization.

- \* During normal operation, the system should be run until both units have reached the fully lowered position or the fully stored position.
- \* Check to make sure the ladders are evenly placed on the system. There should be the same number of rungs hanging off each end of the system.
- \* With an electronic tester, measure the voltage just before the actuators. If the voltage differs by 0.5 volts or more, adjustments will have to be made to your wiring.
- \* Check the wire to the actuators for proper gauge. Gauge size depends on length of wire. Consult a qualified electrician for gauge size.
- \* Wires leading from the power source to each actuator should be the same length within a few feet.
- \* Follow the wire path from the power source to the electric actuators. Look for door interlock switches (switches that prevent the unit from operating if a door is open) that are wired directly through the power wire. These switches are rarely rated for the amperage needed to operate the system. This will have a major adverse effect on the system. For most applications 10 gauge wire is sufficient. Power must be run directly to the switch, then directly to the actuator. Switches must be wired using relays rated for at least 75 amps.

### **SOLUTION:**

Implement this into the normal usage of system.

Space ladders evenly or counterweight the lighter side.

See Below

Wire must be replaced if undersized.

Have a qualified technician add wire to the shorter length until they are even.

Have a qualified electrician rewire the system so that the door interlock switches are wired through relays.

# WARRANTY REGISTRATION

PLEASE MAIL OR FAX A COPY TO ZICO TO REGISTER YOUR UNIT

FIRE DEPARTMENT NAME: \_\_\_\_\_ CONTACT PERSON: \_\_\_\_\_

PHONE NO. \_\_\_\_\_ FAX NO. \_\_\_\_\_

STREET ADDRESS: \_\_\_\_\_ P.O. BOX: \_\_\_\_\_

CITY: \_\_\_\_\_ STATE: \_\_\_\_\_ ZIP: \_\_\_\_\_

MODEL NO. (CHECK ONE):  
\_\_\_\_\_ LAS-HA-775 \_\_\_\_\_ HSS-SAT-10  
\_\_\_\_\_ LAS-HA-975  
\_\_\_\_\_ LAS-HA-1200

SERIAL NO. ON UNIT: (SEE PAGE 15 OR 17 FOR LOCATION) \_\_\_\_\_

INSTALLED ON: (VEHICLE MFG.) \_\_\_\_\_ DELIVERED: (DATE) \_\_\_\_\_

WAS UNIT INSTALLED ON: \_\_\_\_\_ NEW VEHICLE

\_\_\_\_\_ RETROFITTED ONTO EXISTING VEHICLE

OPTIONS INSTALLED ON YOUR UNIT (CHECK ALL THAT APPLY):

_____ LAS-FLB	_____ FLB	_____ LAS-LGK
_____ LAS-FLB/PPMB	_____ FLBA	_____ HARD SLEEVE TRAY
_____ PPMB-AA	_____ LAS-HA-FLK	_____ OTHER _____
_____ PPMB-BB	_____ LAS-MSL	_____ OTHER _____

LADDERS MOUNTED ON THE UNIT:

DUO SAFETY _____ FT. EXTENSION, MODEL _____	ALCO LITE _____ FT. EXTENSION, MODEL _____
DUO SAFETY _____ FT. ROOF, MODEL _____	ALCO LITE _____ FT. ROOF, MODEL _____
DUO SAFETY _____ FT. _____, MODEL _____	ALCO LITE _____ FT. _____ MODEL _____

HARD SLEEVE MOUNTED ON THE UNIT:

\_\_\_\_\_ FT LIGHT WEIGHT \_\_\_\_\_ STRAINER ATTACHED TO SLEEVE \_\_\_\_\_ YES \_\_\_\_\_ NO  
\_\_\_\_\_ FT STANDARD WEIGHT

WHERE DID YOU HEAR ABOUT OUR PRODUCT?

\_\_\_\_\_ MAGAZINE AD (SPECIFY) \_\_\_\_\_  
\_\_\_\_\_ DEALER (SPECIFY) \_\_\_\_\_  
\_\_\_\_\_ VEHICLE MFG. (SPECIFY) \_\_\_\_\_  
\_\_\_\_\_ ANOTHER DEPARTMENT (SPECIFY) \_\_\_\_\_  
\_\_\_\_\_ OTHER (SPECIFY) \_\_\_\_\_