

COLLISION RESTRAINT STRAP MODELS CRS AND CRS/S

ATTACHING THE COLLISION RESTRAINT STRAP TO YOUR WALKAWAY® BRACKET

If your WALKAWAY® Bracket was manufactured after January 1, 1992, the CRS should bolt directly to the bracket as shown at left. This bracket will be readily identified as having 6 hole sets in the NF footplate and UN backplate.

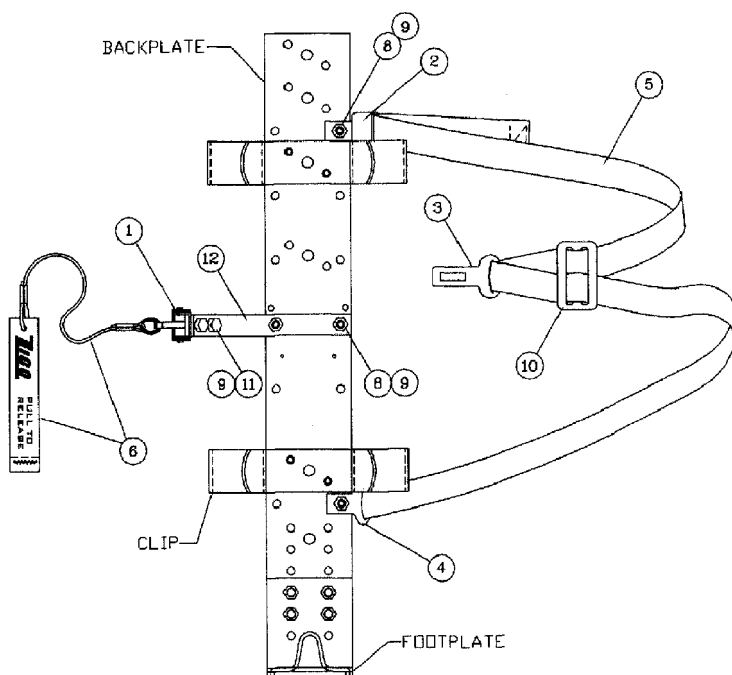

ITEM NO.	PART NO.	DESCRIPTION
1	1010-120-903	Latch assembly
2	1010-120-035	Cam buckle assembly
3	1010-120-050	Tab latch
4	1010-120-055	Retainer strap
5	1010-120-060	Nylon strap assembly
6	1010-120-005	Lanyard & pull tab
8	9010-462509	1/4-20 x 9/16 bolt (4 Pcs.) Torx
9	9013-172500	1/4-20 lock nut (6 Pcs.)
10	3099-000-015	Tri glide (CPTG000001)
11	9010-102508	1/4-20 x 1/2 bolt (2 Pcs.)
12	1010-120-175	Latch extension
	1010-000-180	Latch ext.-Bostrom Seat
	1010-000-185	Latch ext.-Seats Inc. Seat

NOTE: Straps may be attached on either the left or right side of the bracket as matching holes are provided on both sides. Cam and buckle assembly (item no. 2) may be mounted above or below top clip if the CRS strap interferes with hoses on the air pack assembly.

MODEL NO.	PART NO.	DESCRIPTION
CRS	1010-120-000	Standard CRS
CRS/S	1010-125-000	CRS with Switch
CRS-180	1010-122-000	For Bostrom Seats
CRS-185	1010-124-000	For Seats, Inc. Seats

If your WALKAWAY® bracket was manufactured prior to January 1, 1992, the bracket will have 7 hole sets in the NF footplate and UN backplate and additional holes will have to be drilled as shown at right. The footplate may be cut off between the 6 and 7th hole sets or moved down one set of holes.

All bolts are inserted from the back side of the bracket with the nut attached on the front (clip side) of bracket. All tabs (on items 1, 2 & 4) are to be placed on the front side of the bracket.

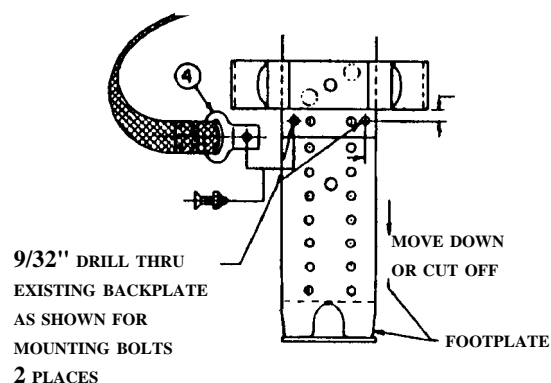

DONNING YOUR SCBA

Our new CRS (Collision Restraint Strap) will permit fire personnel to be strapped into the SCBA in a ready state and also wear the standard 3 point safety belt.

The suggested procedure for doing this is as follows:

Prior to departure from fire station:

- Fire Fighter sits in seat and puts his/her arms through SCBA shoulder straps. Slack should be taken up on these straps but not tightened firmly. The SCBA waist strap should not be put on.
- The fire fighter should now put on his/her 3-point safety belt.

Upon arrival at emergency scene:

- When the apparatus comes to a full and complete stop, personnel should remove their 3-point occupant safety belt.
- Release the Collision Restraint Strap by giving a firm tug on the release pull tab (Item 6).
- The fire fighter is now free to leave his/her seat, with the SCBA on his/her back.
- Outside of the crew cab, the shoulder straps can be properly tightened and waist belt buckled.

NOTE: 3-point safety belts should be used. SCBA are not designed to provide occupant restraint. Our CRS strap is designed to restrain the SCBA in an accident, not the occupant.

Used correctly, the CRS strap will provide a safe means of storing SCBA while keeping it readily accessible.



Ziamatic Corp.

10 West College Avenue, P.O. Box 337, Yardley, PA 19067-8337 • (215) 493-3618 • FAX: (215) 493-1401

*ZICO is a registered trademark for fire, safety and marine products made by Ziamatic Corp.

WWW.ZIAMATIC.COM
CALL TOLL FREE (800) 711-FIRE

Copyright Ziamatic Corp. 7-06