



TECHNICAL DATA

ESFR DRY PENDENT SPRINKLER VK502 (K14.0)

The Viking Corporation, 210 N Industrial Park Drive, Hastings MI 49058

Telephone: 269-945-9501 Technical Services: 877-384-5464 Fax: 269-818-1680 Email: techsvcs@vikingcorp.com

1. DESCRIPTION

Viking Early Suppression Fast Response (ESFR) Dry Pendent Sprinkler VK502 is a fast response fusible element type sprinkler designed for use in storage areas subject to freezing and supplied from a wet system in an adjacent heated area. With a 14.0 (202 metric*) nominal K-Factor and special deflector, this sprinkler produces large, high-momentum water droplets in a hemispheric pattern below the deflector. This permits penetration of the fire plume and direct wetting of the burning fuel surface while cooling the atmosphere early in the development of a high-challenge fire.

The dry ESFR sprinkler consists of a fusible element style ESFR sprinkler permanently secured to a special supply nipple. The sprinkler assembly features a sealed brass inlet that's grooved or threaded. Also included with the ESFR dry sprinkler are two insulating boot assemblies (optional) to help seal the clearance space around the dry sprinkler barrel. When properly installed, the seal decreases the potential for leakage of air through the opening in the ceiling and consequent formation of condensate around the sprinkler connection on the system piping. In freezer installations, condensation can lead to ice build-up, which could inhibit sprinkler operation or cause premature sprinkler operation. The dry sprinkler boot assembly is intended to slow the exchange of air between the inside and outside of the freezer (or any dry sprinkler installation) to help prevent humidity and temperature differential in the area around the sprinkler. The rubber seal is designed with a material that will not drip when exposed to open flame. This protects the deflector from acquiring material that would impede its water distribution characteristics.

NOTICE: Viking recommends use of the included insulating boot assemblies in accordance with the installation instructions in this technical data page. Insulating boot assemblies (optional) are recommended to be installed on smooth, flat, and clean surfaces. There are specific situations, such as corrugated ceiling panels, where alternative penetration sealing methods are utilized. For additional information contact Viking Technical Services.

Viking ESFR Dry Pendent VK502 Sprinklers provide protection of most common storage materials, open-framed rack storage arrangements of Class I, II, III, and IV commodities, and cartoned unexpanded plastic up to 35ft. (10.7m) storage with a 40ft. (12.0m) ceiling height*.

- For specific application and installation requirements, reference the latest applicable FM Loss Prevention Data Sheets (including Data Sheet 2-0 and 8-9).

*Refer the Approval Chart and Design Criteria on page 122m for FM Approval requirements that must be followed.

2. LISTINGS AND APPROVALS

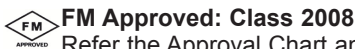

Refer the Approval Chart and Design Criteria on page 122m for FM Approval requirements

that must be followed.



**ESFR DRY SPRINKLERS CAN ONLY BE INSTALLED IN WET SYSTEMS!
NOT FOR INSTALLATION IN DRY OR PREACTION SYSTEMS.**

3. TECHNICAL DATA

Specifications:

Available since 2012.

Tube diameter: 1-11/16" (43.86 mm)

Minimum Operating Pressure: Refer to NFPA 13.

Maximum Working Pressure: 175 psi (12 bar). Factory tested hydrostatically to 500 psi (34.5 bar).

**Connections: 2" grooved (refer to Figures 1 and 2) or
1-1/2" NPT or BSP Threaded (refer to Figures 3 and 4)**

Nominal K-Factor: 14.0 U.S. (202 metric*)

*Metric K-factor measurement shown is when pressure is measured in bar. When pressure is measured in kPa, divide the metric K-factor shown by 10.0.

Deflector Diameter: 1-13/32" (35.7 mm)

Overall Length: 36-5/8" (930 mm)

Patent Pending

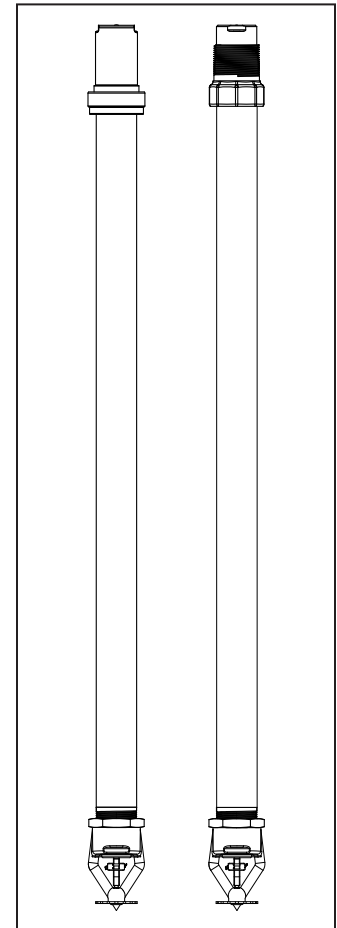

**ESFR Sprinkler VK502
(Grooved and Threaded)**

Viking Technical Data may be found on
The Viking Corporation's Web site at
<http://www.vikinggroupinc.com>.
The Web site may include a more recent
edition of this Technical Data Page.



TECHNICAL DATA

ESFR DRY PENDENT SPRINKLER VK502 (K14.0)

The Viking Corporation, 210 N Industrial Park Drive, Hastings MI 49058

Telephone: 269-945-9501 Technical Services: 877-384-5464 Fax: 269-818-1680 Email: techsvcs@vikingcorp.com

Insulating Boot Assemblies (2 ea): The boot consists of a rubber foam seal covered with a two-piece ring fastened to the ceiling or deck with two screws.

Outside Diameter: 6" (152 mm)

Depth: 1" (25 mm)

Material Standards:

Sprinkler Frame Casting: Brass UNS-C84400

Deflector: Phosphor Bronze UNS-C51000

Seat: Brass UNS-C36000

Belleville Spring Sealing Assembly: Nickel Alloy, coated on both sides with Polytetrafluoroethylene (PTFE) Tape

Spring Base: Brass UNS-C31400 or UNS-C31600

Back-Up Nut: Brass UNS-C36000

Compression Screw: Stainless Steel UNS-S31603

Trigger and Support: Stainless Steel UNS-S31600

Fusible Element Assembly: Beryllium Nickel, coated with polyurethane

Tube: Steel Tube ASTM A-513, Brass UNS-C36000

Orifice: Brass UNS-C36000

Inlet Casting : Brass UNS-C84400

Support (Internal): Brass UNS-C36000

Barrel: Steel Tube ASTM A-513, Electrodeposited Epoxy Base finish, Brass UNS-C36000

Boot Assemblies:

Seal: Neoprene/EPDM/SBR

Over Seal Ring and Under Seal Ring: Cold Rolled Steel

Finish: White Paint

#10 Screws: Stainless Steel

Ordering Information: (Also refer to the current Viking price list.)

Order ESFR Dry Pendent Sprinkler VK502 by first adding the appropriate suffix for the sprinkler finish, the appropriate suffix for the temperature rating. Note: Sprinkler VK502 is available in one length only.

Sprinkler Base Part Number for 2" Grooved: 18176

Sprinkler Base Part Number for 1-1/2" NPT Threaded: 18177

Sprinkler Base Part Number for 1-1/2" BSP Threaded: 18178

Finish Suffix: Brass = A

Temperature Suffix (°F/°C): 165°/74° = C

For example, sprinkler VK502 with 2" grooved connections, Brass finish and a 165 °F/74 °C temperature rating = Part No. 18176AC (includes 2 insulating boot assemblies).

Available Finishes And Temperature Ratings:

Refer to Table 1.

Accessories: (Also refer to the "Sprinkler Accessories" section of the Viking data book.)

Sprinkler Wrenches:

A. For Sprinklers 18176 (Grooved): Use a crescent wrench or socket applied on the grooved coupling

B. For Sprinkler 18177 and 18178 (Threaded): Use a pipe wrench applied on the inlet housing

Replacement Insulating Boot Assemblies:

A. Base Part No. 13863

4. INSTALLATION

WARNING

Viking sprinklers are manufactured and tested to meet rigid requirements of the approving agency. The sprinklers are designed to be installed in accordance with recognized installation standards. System design must be based on ESFR design guidelines described in the latest edition of Viking technical data, applicable FM Global Loss Prevention Data Sheets, the latest NFPA Standards, the Authorities Having Jurisdiction, and also with the provisions of governmental codes, ordinances, and standards whenever applicable. Deviation from the standards or any alteration to the sprinkler after it leaves the factory including, but not limited to: painting, plating, coating, or modification, may render the sprinkler inoperative and will automatically nullify the approval and any guarantee made by The Viking Corporation.



TECHNICAL DATA

ESFR DRY PENDENT SPRINKLER VK502 (K14.0)

The Viking Corporation, 210 N Industrial Park Drive, Hastings MI 49058

Telephone: 269-945-9501 Technical Services: 877-384-5464 Fax: 269-818-1680 Email: techsvcs@vikingcorp.com

TABLE 1: AVAILABLE SPRINKLER TEMPERATURE RATINGS AND FINISHES

Sprinkler Temperature Classification	Sprinkler Nominal Temperature Rating ¹	Maximum Ambient Ceiling Temperature ²	Frame Paint Color
Ordinary	165 °F (74 °C)	100 °F (38 °C)	None

Sprinkler Finish: Brass

Footnotes

¹ The sprinkler temperature rating is stamped on the deflector.

² Based on NFPA-13. Other limits may apply, depending on fire loading, sprinkler location, and other requirements of the Authority Having Jurisdiction. Refer to specific installation standards.

Sprinklers must be handled with care. They must be stored in a cool, dry place in their original shipping container. Never install sprinklers that have been dropped or damaged in any way. Such sprinklers should be destroyed immediately. **NOTICE:** Wet pipe systems must be provided with adequate heat.

Viking ESFR Dry Sprinklers are to be installed into the 2" grooved or 1-1/2" threaded run of malleable, ductile iron tee fittings that meet the dimensional requirements of ANSI B16.3 (Class 150), or cast iron threaded tee fittings that meet the dimensional requirements of ANSI B16.4 (Class 125), even at branch line ends.

- **DO NOT** install the dry sprinkler into a threaded elbow, coupling, or any other fitting that could interfere with thread penetration. Such installation would damage the brass seal.
 - **NEVER** try to modify dry sprinklers. They are manufactured for specific dimensions and must NOT be modified.
- A. The sprinklers must be installed after the piping is in place to prevent mechanical damage. Before installing, be sure to have the appropriate sprinkler model and style, with the correct orifice size, temperature rating, and response characteristics.
- B. For grooved sprinkler 18176, with the sprinkler contained in the plastic protective shield, apply a lube such as Gruvlok Xtreme™. For threaded sprinklers 18177 and 18178, apply a small amount of pipe-joint compound or tape to the external threads of the barrel only, while taking care not to allow a build-up of compound or tape over the brass inlet and seal.
- C. **For grooved sprinkler 18176, use a crescent wrench or socket applied to a coupling over the sprinkler inlet connection. To install threaded sprinklers 18177 and 18178, use a pipe wrench applied to the sprinkler inlet housing. With the sprinkler contained in the protective shield, install the sprinkler onto the piping, while taking care not to damage the sprinkler.**
- DO NOT use any other type of wrench, as this could damage the unit.
 - DO NOT use the sprinkler deflector or fusible element to start or thread the sprinkler into a fitting.
 - Higher levels of torque may distort the sprinkler inlet with consequent leakage or impairment of the sprinkler.
- D. Clean the contact surfaces of the dry sprinkler insulating boot assemblies and the surfaces are recommended to be smooth and flat.
- E. Refer to Figures 1 and 3 on pages 122n and 122o. Install the dry sprinkler boot assemblies around the dry sprinkler barrel and to the freezer until the seals rest flush against the top of the freezer.
- F. Assemble the rings onto the seals, hold in place, and tighten the screws through the holes provided in the assemblies to secure the insulating ring to the top of the freezer. NOTE: A #29 drill is required for a pilot hole in metallic ceilings.
- G. After installation, the entire sprinkler system must be tested. The test must be conducted to comply with the Installation Standards. Make sure the sprinkler has been properly tightened. If a thread leak occurs, normally the unit must be removed, new pipe-joint compound or tape applied, and then reinstalled. This is due to the fact that when the joint seal is damaged, the sealing compound or tape is washed out of the joint. Air testing the sprinkler piping prior to testing with water may be considered in areas where leakage during testing must be prevented. Refer to the appropriate technical data and the AHJ prior to air testing the sprinkler piping. Immediately replace any damaged units, using the designated wrench only.
- H. **After installation and testing and repairing of all leaks, remove the protective shields from the sprinklers by hand. Do NOT use any type of tool to remove the shield. When removing shields, use care to prevent damaging sprinkler fusible element. THE SHIELDS MUST BE REMOVED FROM SPRINKLERS BEFORE PLACING THE SYSTEM IN SERVICE!**
- I. System design must be based on ESFR design guidelines described in the latest National Fire Protection Association standards, FM loss prevention data sheets, and the Authorities Having Jurisdiction. All requirements of recognized ESFR storage sprinkler system design standards apply to systems utilizing Viking ESFR Dry Pendent Sprinklers.

	<h2 style="margin: 0;">TECHNICAL DATA</h2>	<h3 style="margin: 0;">ESFR DRY PENDENT SPRINKLER VK502 (K14.0)</h3>
-----------------------------------------------------------------------------------	--------------------------------------------	--------------------------------------------------------------------------

The Viking Corporation, 210 N Industrial Park Drive, Hastings MI 49058
 Telephone: 269-945-9501 Technical Services: 877-384-5464 Fax: 269-818-1680 Email: techsvcs@vikingcorp.com

Approval Chart ESFR Dry Pendent Sprinkler VK502 Maximum 175 PSI (12 bar) WWP																	
<table border="1" style="border-collapse: collapse;"> <tr> <td style="padding: 2px;">Temperature</td> <td style="text-align: right; padding: 2px;">KEY</td> </tr> <tr> <td style="padding: 2px;">Finish</td> <td></td> </tr> <tr> <td style="padding: 2px;">A1X ← Escutcheon (if applicable)</td> <td></td> </tr> </table>												Temperature	KEY	Finish		A1X ← Escutcheon (if applicable)	
Temperature	KEY																
Finish																	
A1X ← Escutcheon (if applicable)																	
Base Part Number ¹	SIN	Connections	Nominal K-Factor		Listings and Approvals ^{3,4} (Refer also to Design Criteria on page 122d.)												
			U.S.	metric ²	UL	FM	NYC	VdS	LPCB	CE							
18176	VK502	2" Grooved	14.0	202	--	A1	--	--	--	--	--						
18177	VK502	1-1/2" NPT Threaded	14.0	202	--	A1	--	--	--	--	--						
18178	VK502	1-1/2" BSP Threaded	14.0	202	--	A1	--	--	--	--	--						
Approved Temperature Rating A - 165 °F (74 °C)						Approved Finish 1 - Brass											
Footnotes																	
¹ Base part number shown. For complete part number, refer to the price list. ² Metric K-Factor measurement shown is when pressure is measured in bar. When pressure is measured in kPa, divide the metric K-Factor shown by 10.0. ³ This chart shows listings and approvals available at the time of printing. Other approvals may be in process. ⁴ FM Approved as a quick response pendent Non-Storage sprinkler and also FM Approved as a quick response pendent Storage sprinkler. Refer to Design Criteria below.																	

DESIGN CRITERIA
(Also refer to the Approval Chart above.)

FM Approval Requirements:

1. Sprinkler VK502 is FM Approved as a quick response pendent **Storage** sprinkler as indicated in the FM Approval Guide.
 - For specific application and installation requirements, reference the latest applicable FM Loss Prevention Data Sheets (including Data Sheets 2-0 and 8-9).
 2. Sprinkler VK502 is also FM Approved as a quick response pendent **Non-Storage** sprinkler as indicated in the FM Approval Guide.
 - For specific application and installation requirements, reference the latest applicable FM Loss Prevention Data Sheets (including Data Sheet 2-0).
- FM Global Loss Prevention Data Sheets contain guidelines relating to, but not limited to: minimum water supply requirements, hydraulic design, ceiling slope and obstructions, minimum and maximum allowable spacing, and deflector distance below the ceiling.

NOTICE: The FM installation guidelines may differ from NFPA criteria.

IMPORTANT: Always refer to Bulletin Form No. F_091699 - Care and Handling of Sprinklers. Viking ESFR Dry Pendent Sprinklers are to be installed in accordance with the latest edition of Viking technical data, the latest standards of NFPA, and any other Authorities Having Jurisdiction, and also with provisions of governmental codes, ordinances, and standards whenever applicable.



TECHNICAL DATA

ESFR DRY PENDENT
SPRINKLER VK502 (K14.0)

The Viking Corporation, 210 N Industrial Park Drive, Hastings MI 49058

Telephone: 269-945-9501 Technical Services: 877-384-5464 Fax: 269-818-1680 Email: techsvcs@vikingcorp.com

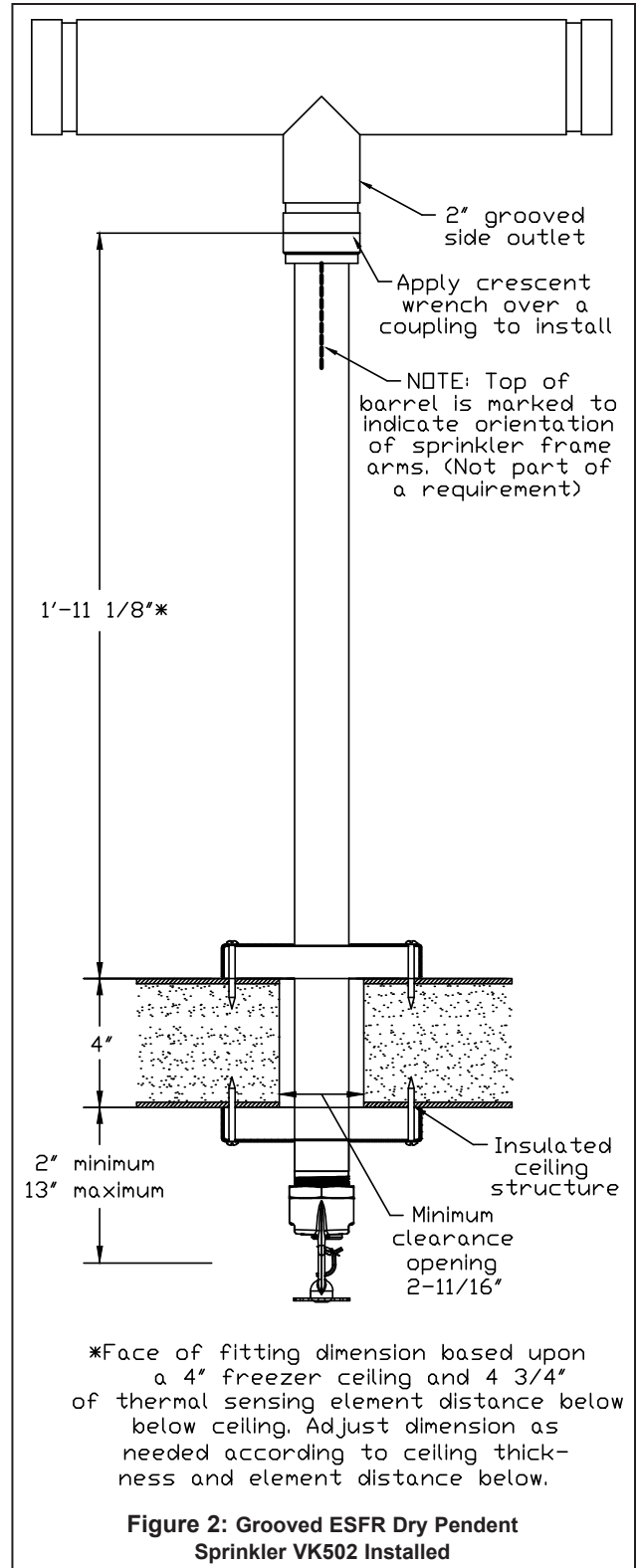
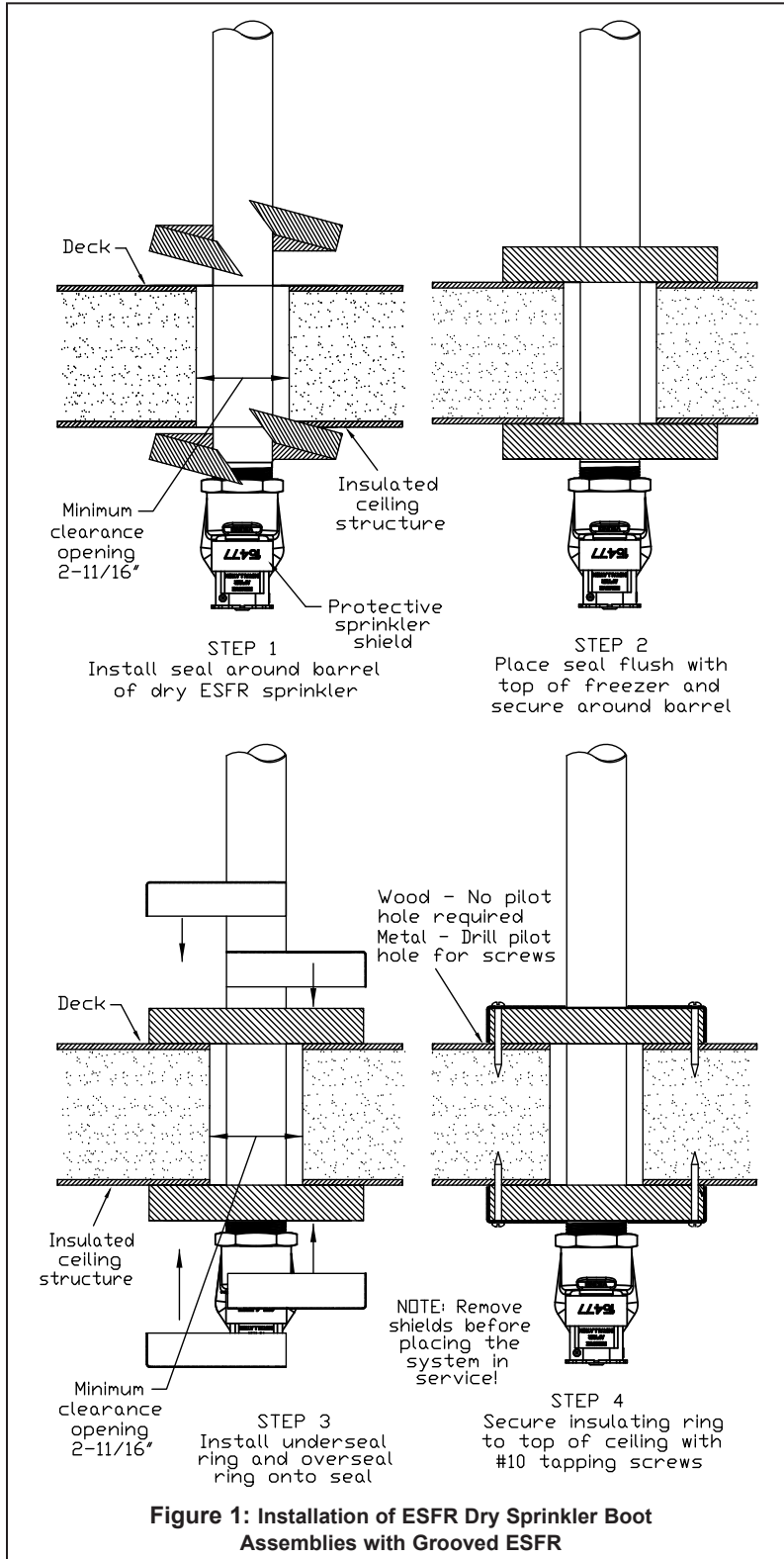



TECHNICAL DATA

**ESFR DRY PENDENT
SPRINKLER VK502 (K14.0)**

The Viking Corporation, 210 N Industrial Park Drive, Hastings MI 49058

Telephone: 269-945-9501 Technical Services: 877-384-5464 Fax: 269-818-1680 Email: techsvcs@vikingcorp.com

5. OPERATION

During fire conditions, the heat-sensitive fusible element assembly disengages, releasing the internal parts to open the waterway. Water flowing through the sprinkler orifice strikes the sprinkler deflector, forming a uniform spray pattern to suppress the fire.

6. INSPECTIONS, TESTS AND MAINTENANCE

NOTICE: The owner is responsible for maintaining the fire protection system and devices in proper operating condition. For minimum maintenance and inspection requirements, refer to the NFPA standard that describes care and maintenance of sprinkler systems. In addition, the Authorities Having Jurisdiction may have additional maintenance, testing, and inspection requirements that must be followed.

- A. The sprinklers must be inspected on a regular basis for corrosion, mechanical damage, obstructions, paint, etc. The frequency of inspections may vary due to corrosive atmosphere, water supplies, and activity around the device.
- B. Sprinklers that have been painted or mechanically damaged must be replaced immediately. Sprinklers showing signs of corrosion shall be tested and/or replaced immediately as required. Installation standards require sprinklers to be tested and, if necessary, replaced after a specified term of service. For Viking ESFR Dry Pendent Sprinklers, refer to the Installation Standards (e.g., NFPA 25) and the Authorities Having Jurisdiction for the specified period of time after which testing and/or replacement is required. Sprinklers that have operated cannot be reassembled or reused, but must be replaced. When replacing sprinklers, use only new sprinklers.
- C. The sprinkler discharge pattern is critical for proper fire protection. Therefore, nothing should be hung from, attached to, or otherwise obstruct the discharge pattern. All obstructions must be immediately removed or, if necessary, additional sprinklers installed.
- D. When replacing existing sprinklers, the system must be removed from service. Refer to the appropriate system description and/or valve instructions. Prior to removing the system from service, notify all Authorities Having Jurisdiction. Consideration should be given to employment of a fire patrol in the affected area.
 - 1. Remove the system from service, drain all water, and relieve all pressure on the piping.
 - 2. Remove the ESFR dry sprinkler insulating boot assemblies.
 - 3. Using the designated wrench, remove the old sprinkler and install the new unit. Care must be taken to ensure that the replacement sprinkler is the proper model and style, with the correct orifice size, temperature rating, and response characteristics.
 - 4. Install new ESFR dry sprinkler boot assemblies.
 - 5. Place the system back in service and secure all valves. Check the replaced sprinklers and repair all leaks.
- E. Sprinkler systems that have been subject to a fire must be returned to service as soon as possible. The entire system must be inspected for damage and repaired or replaced as necessary. Sprinklers that have been exposed to corrosive products of combustion, but have not operated, should be replaced. Refer to the Authorities Having Jurisdiction for minimum replacement requirements.

7. AVAILABILITY

The Viking Model VK502 Sprinkler is available through a network of domestic and international distributors. See The Viking Corporation web site for the closest distributor or contact The Viking Corporation.

8. GUARANTEE

For details of warranty, refer to Viking's current list price schedule or contact Viking directly.

Ambient Temperature of Protected Area* at the Discharge End of the Sprinkler	Exposed Barrel Ambient Temperature		
	40°F/4°C	50°F/10°C	60°F/16°C
	Exposed Minimum Barrel Length** Face of Tee to Top of Ceiling		
	In. (mm)	In. (mm)	In. (mm)
40°F (4°C)	0	0	0
30°F (-1°C)	0	0	0
20°F (-7°C)	4 (100)	0	0
10°F (-12°C)	8 (203)	1 (25.4)	0
0°F (-18°C)	12 (305)	3 (76)	0
-10°F (-23°C)	14 (356)	4 (102)	1 (25.4)
-20°F (-29°C)	14 (356)	6 (152)	3 (76)
-30°F (-34°C)	16 (406)	8 (203)	4 (102)
-40°F (-40°C)	18 (457)	8 (203)	4 (102)
-50°F (-46°C)	20 (508)	10 (254)	6 (152)
-60°F (-51°C)	20 (508)	10 (254)	6 (152)

*The protected area refers to the area below the ceiling. The ambient temperature is the temperature at the discharge end of the sprinkler. For protected area temperatures that occur between the values listed, use the next cooler temperature.

NOTE: Exposed minimum barrel lengths are inclusive up to 30 mph wind velocities.

**3: Required Dry Pendent Sprinkler
Minimum Barrel Length Based on Ambient Temperature
(Grooved ESFR Dry Pendent Sprinkler Shown)**



TECHNICAL DATA

ESFR DRY PENDENT
SPRINKLER VK502 (K14.0)

The Viking Corporation, 210 N Industrial Park Drive, Hastings MI 49058

Telephone: 269-945-9501 Technical Services: 877-384-5464 Fax: 269-818-1680 Email: techsvcs@vikingcorp.com

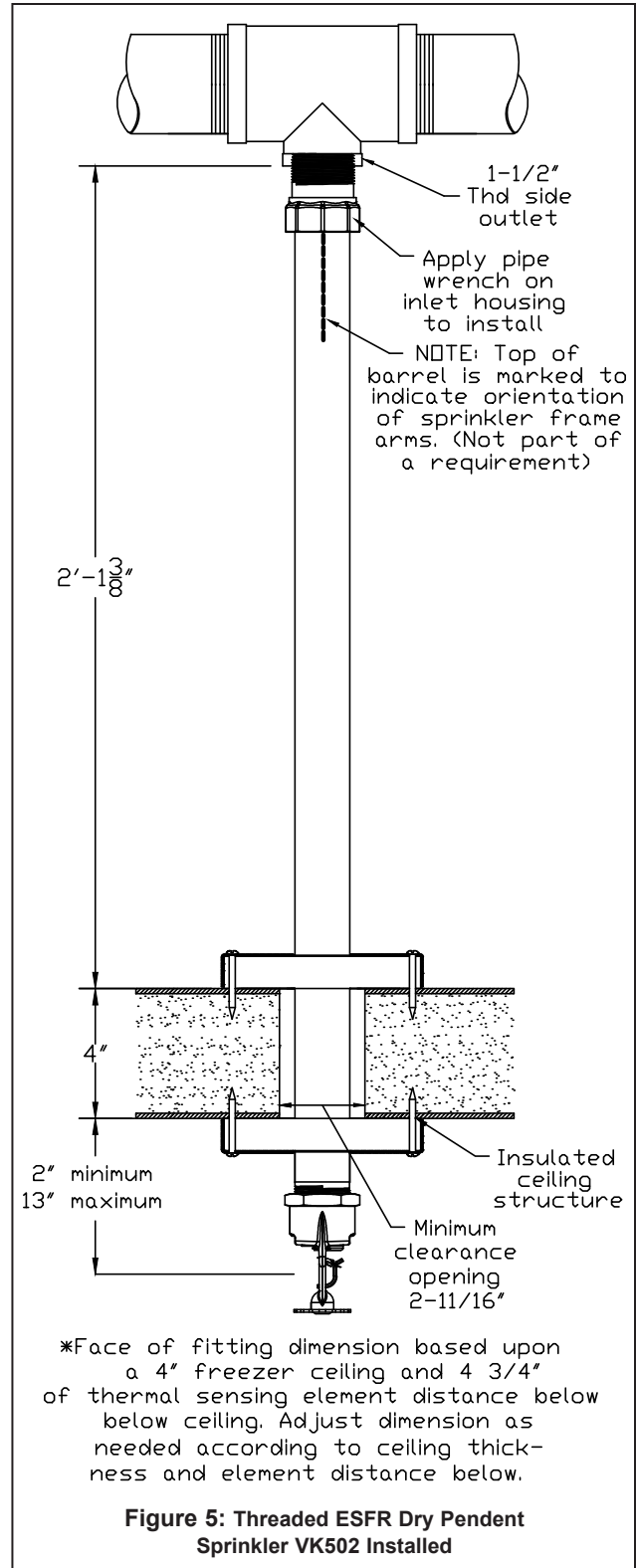
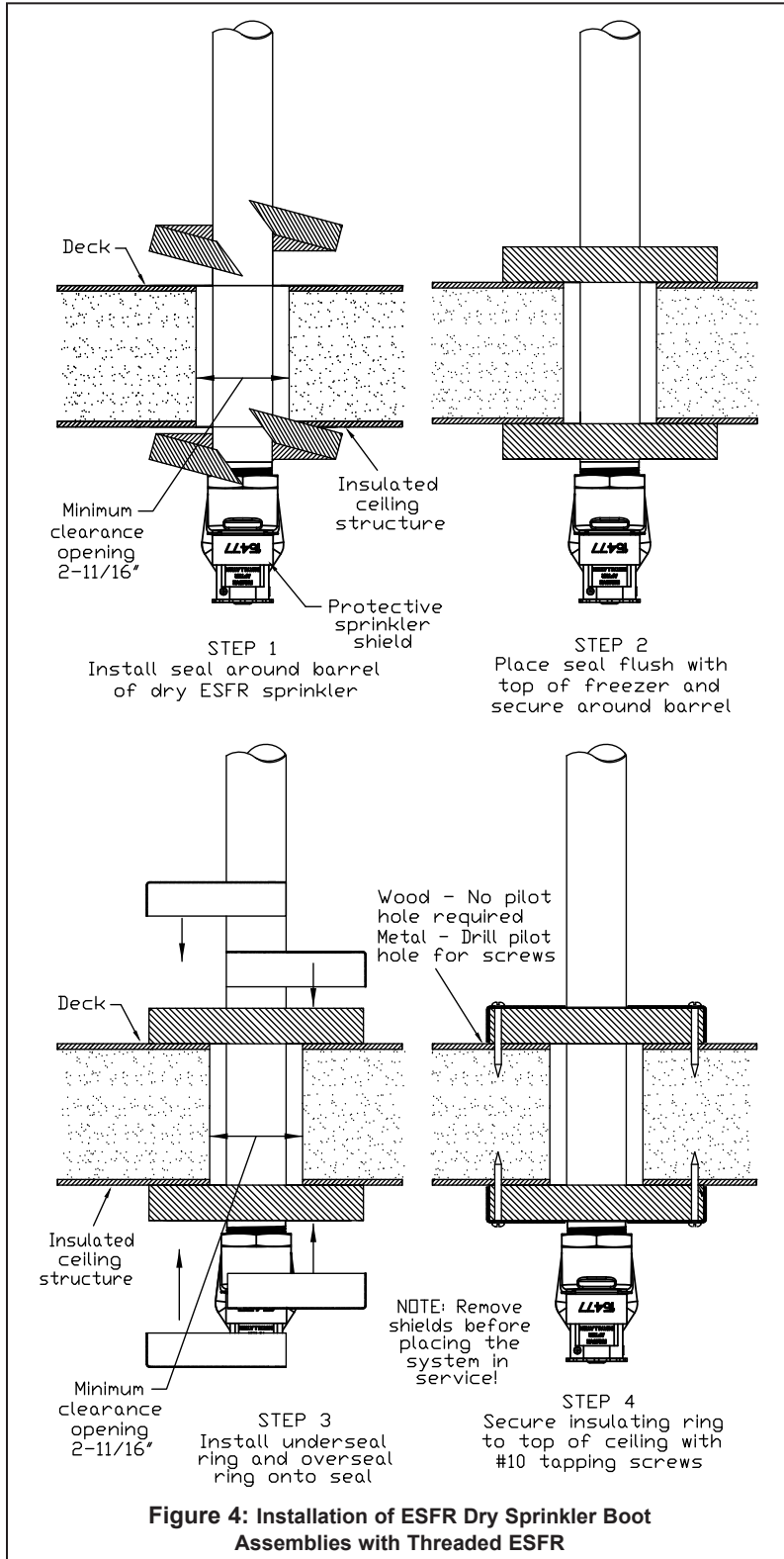



TECHNICAL DATA

**ESFR DRY PENDENT
SPRINKLER VK502 (K14.0)**

The Viking Corporation, 210 N Industrial Park Drive, Hastings MI 49058
 Telephone: 269-945-9501 Technical Services: 877-384-5464 Fax: 269-818-1680 Email: techsvcs@vikingcorp.com

