

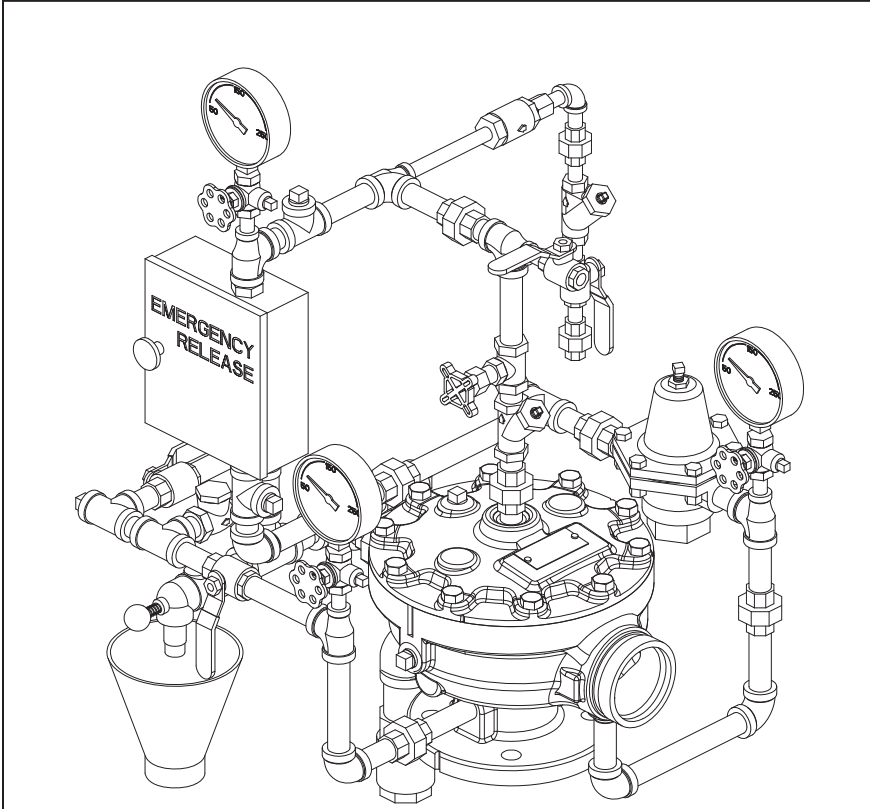

TECHNICAL DATA

PILOT REGULATING FLOW CONTROL TRIM 3" (DN80) MODEL H FLOW CONTROL VALVE

The Viking Corporation, 210 N Industrial Park Drive, Hastings MI 49058
 Telephone: 269-945-9501 Technical Services: 877-384-5464 Fax: 269-818-1680 Email: techsvcs@vikingcorp.com
 Visit the Viking website for the latest edition of this technical data page: www.vikinggroupinc.com



Valve Size	Galvanized Trim Part No.	Brass Trim Part No.
3" (DN80)	14765-1	14765-2
This trim is for use with the following Release Module Trim Kits		
Release Type	Galvanized	Brass
Electric	10830	10832
Note: Nipple lengths for brass trim may vary from those shown on this Trim Chart.		

Note: When viewing this data page online, [blue](#) text represents hyperlinks and will open the appropriate data page when clicked.

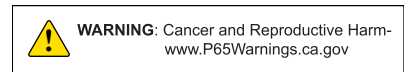

Notes: For use with Trim Charts on Page 2

General Notes:

- Valve must be trimmed as shown. Any deviation from trim size or arrangement may affect the proper operation of the valve.
- Dimensions in parentheses are millimeters.
- Viking uses ANSI tee designations (large outlet on run, small outlet on run, side outlet) in all trim call-outs.

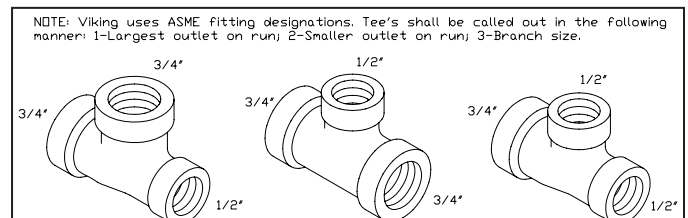

Note 1: Release system connection.

Note 2: Alarm Connections: Connect alarm line piping to 3/4" (20 mm) NPT outlet. When using a water motor alarm, a strainer is required. 1/2" (15 mm) NPT outlet is for electric alarm pressure switch.

Note 3: Optional non-interruptible connection for alarm pressure switch to activate electric alarm panel. Note: After the deluge valve trips, this location cannot be shut off. Alarms may operate until the outlet chamber of the deluge valve is de-pressurized below the set point of the alarm pressure switch.

Note 4: Viking Drain Check Valve is manufactured with a 0.067" (1.7 mm) orifice to allow alarm line to drain. DO NOT substitute. Check the label for proper orientation.



TECHNICAL DATA

PILOT REGULATING FLOW CONTROL TRIM

3" (DN80) MODEL H
FLOW CONTROL VALVE

The Viking Corporation, 210 N Industrial Park Drive, Hastings MI 49058

Telephone: 269-945-9501 Technical Services: 877-384-5464 Fax: 269-818-1680 Email: techsvcs@vikingcorp.com
Visit the Viking website for the latest edition of this technical data page: www.vikinggroupinc.com

Refer to page 1 for
General Notes and
Notes 1 through 4.

Order Flow Control Valve
Separately

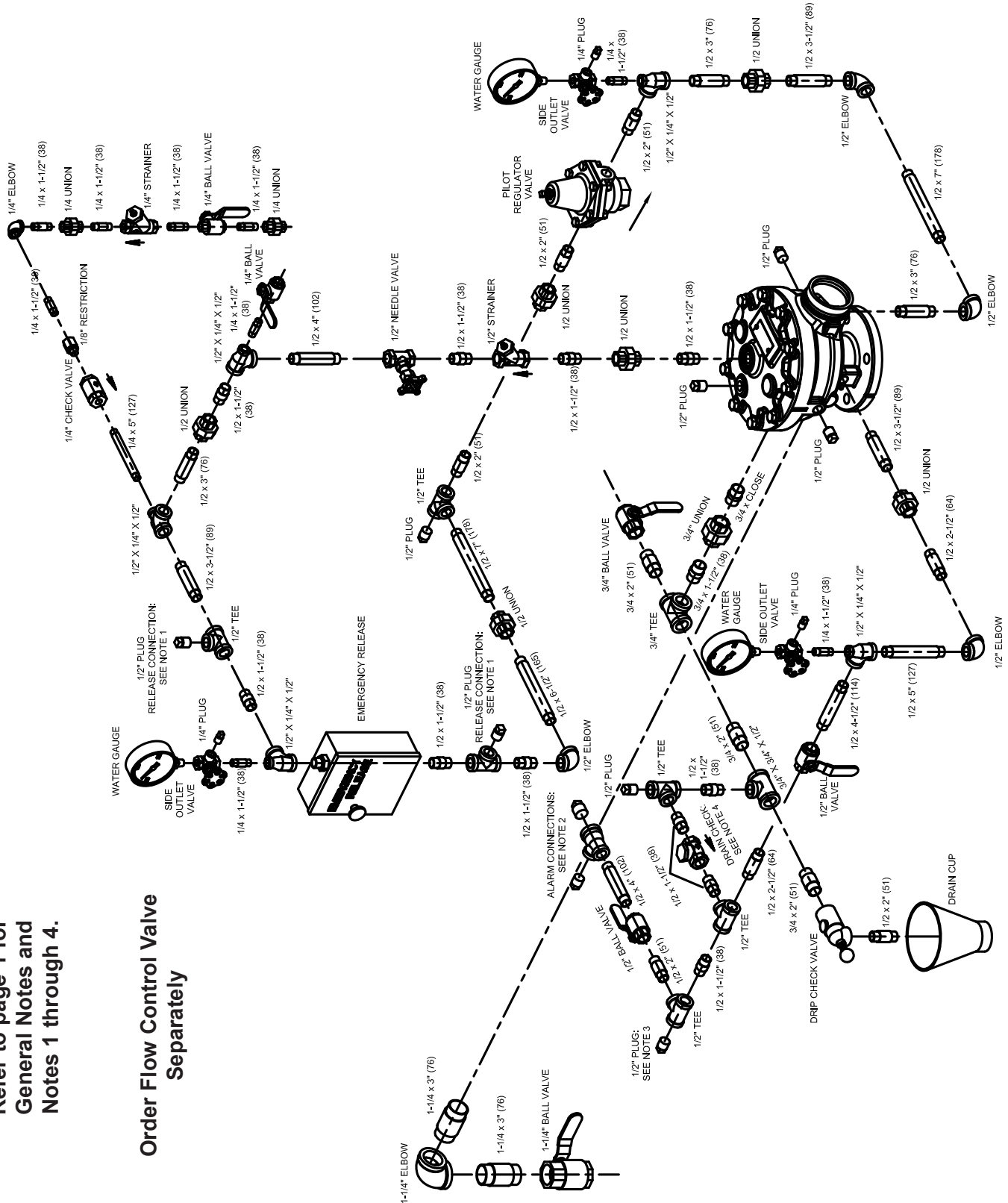

Figure 1
3" Pilot Regulating Flow Control Trim for Model H Flow Control Valve



TECHNICAL DATA

PILOT REGULATING FLOW CONTROL TRIM 3" (DN80) MODEL H FLOW CONTROL VALVE

The Viking Corporation, 210 N Industrial Park Drive, Hastings MI 49058
 Telephone: 269-945-9501 Technical Services: 877-384-5464 Fax: 269-818-1680 Email: techsvcs@vikingcorp.com
 Visit the Viking website for the latest edition of this technical data page: www.vikinggroupinc.com

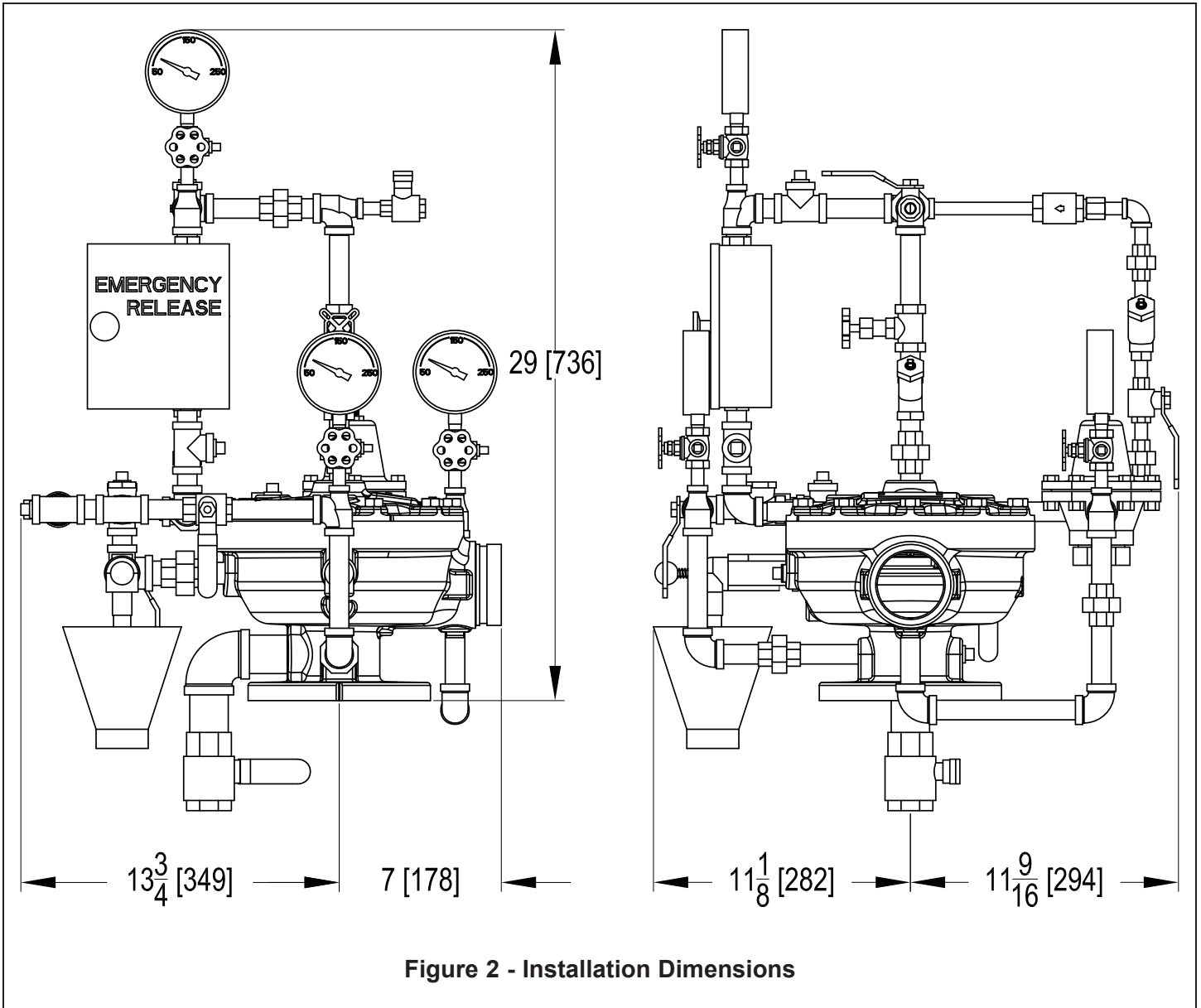

Figure 2 - Installation Dimensions