



TECHNICAL DATA

4" CHECK VALVE MODEL M-2

The Viking Corporation, 210 N Industrial Park Drive, Hastings MI 49058

Telephone: 269-945-9501 Technical Services: 877-384-5464 Fax: 269-818-1680 Email: techsvcs@vikingcorp.com

Visit the Viking website for the latest edition of this technical data page www.vikinggroupinc.com

1. DESCRIPTION

The Viking 4" Model M-2 Check Valve is a general purpose rubber-faced check valve approved for use in fire service systems. The Model M-2 Check Valve is manufactured with a ductile iron body, a stainless steel clapper assembly, brass seat, and an EPDM rubber.

Features

1. Ductile iron body for less weight and extra strength
2. Replaceable rubber seal
3. 1/2" NPT Drain Boss upstream of the seat
4. Lightweight, less than 12 lbs.
5. Spring loaded to prevent water hammer

2. LISTINGS AND APPROVALS

cULus Listed - Guide HMER

FM Approved - Single Check Valves

NYC Department of Buildings - MEA 89-92-E Vol. 40



3. TECHNICAL DATA

Specifications:

Rated to 250 psi (17.2 bar) water working pressure.

Factory tested hydrostatically to 500 psi (34.5 bar).

Standard Grooved Connections - ANSI/AWWA C606

Friction Loss: 15' (Expressed in equivalent length of Schedule 40 pipe based on Hazen & Williams formula: $C = 120.$)

Cv Factor: 414

Patent Pending

Material Standards:

Refer to Figure 1

Ordering Information:

4" Valve only

Part Number 22550



WARNING: Cancer and Reproductive Harm-
www.P65Warnings.ca.gov

4. INSTALLATION

The Model M-2 Check Valve must be installed in an area not subject to freezing temperatures or physical damage. When corrosive atmospheres and/or contaminated water supplies are present, it is the owner's responsibility to verify compatibility with the Model M-2 Check Valve. Prior to installing the valve, thoroughly flush the water supply piping to verify that no foreign matter is present. NOTE: The Model M-2 Check Valve may be installed in the vertical position with direction of flow up, or in the horizontal position with the 1/2" drain boss down.

Hydrostatic Test:

The valve is factory tested at 500 psi (34.5 bar). Model M-2 Check Valves may be hydrostatically tested at 300 psi (20.7 bar) and/or 50 psi (3.4 bar) above the normal water working pressure for limited periods of time (two hours) for the purpose of acceptance by the Authority Having Jurisdiction. If air testing is required, do not exceed 80 psi (5.5 bar) air pressure.

5. OPERATION (Refer to Figure 1)

Water flowing through the Viking Model M-2 Check Valve lifts the rubber-gasketed clapper assembly (2) off the seat (3) and flows into the sprinkler piping. When flow through the valve stops, the clapper assembly (2) closes quickly. Rubber gasket (9) forms a tight seal against water seat (3), trapping pressurized water above the clapper and prevents reverse flow from the sprinkler piping.

6. INSPECTIONS, TESTS AND MAINTENANCE

WARNING

Any system maintenance or testing that involves placing a control valve or detection system out of service may eliminate the fire protection capabilities of that system. Prior to proceeding, notify all Authorities Having Jurisdiction. Consideration should be given to employment of a fire patrol in the affected area.



TECHNICAL DATA

4" CHECK VALVE MODEL M-2

The Viking Corporation, 210 N Industrial Park Drive, Hastings MI 49058
 Telephone: 269-945-9501 Technical Services: 877-384-5464 Fax: 269-818-1680 Email: techsvcs@vikingcorp.com
 Visit the Viking website for the latest edition of this technical data page www.vikinggroupinc.com

NOTICE

The owner is responsible for maintaining the fire-protection system and devices in proper operating condition.

The Model M-2 Check Valve and trim must be kept free of foreign matter, freezing conditions, corrosive atmospheres, contaminated water supplies, and any condition that could impair its operation or damage the device.

It is imperative that the system be inspected and tested on a regular basis. The frequency of the inspections may vary due to contaminated water supplies, corrosive water supplies, and corrosive atmospheres. For minimum maintenance and inspection requirements, refer to NFPA 25. In addition, the Authority Having Jurisdiction may have additional maintenance, testing, and inspection requirements that must be followed.

6-A Five-Year Internal Inspection (Refer to Figure 1)

Internal inspection of check valves is recommended every five years unless inspections and tests indicate more frequent inspections are required.

1. Notify the Authority Having Jurisdiction, the system is being taken out of service.
2. Ensure the fire alarm system has been placed in a safe condition and the central station has been notified of the work to prevent a false alarm.
3. Close the water supply main control valve, placing the system out of service.
4. Open the main drain. If necessary, open the system test valve to vent and completely drain the system.
5. Remove check valve from system.
6. Inspect water seat (3). Wipe away all contaminants, dirt, and mineral deposits. Do not use solvents or abrasives.
7. Inspect clapper assembly (2) and rubber (9). Replace damaged or worn rubber parts as required.

NOTE: THE CLAPPER ASSEMBLY IS NOT REPLACEABLE. IF IT IS DETERMINED THAT THE CLAPPER IS DAMAGED, THE VALVE MUST BE REPLACED.

CAUTION

Never apply any lubricant to seats, gaskets, or any internal operating parts of the valve. Petroleum-based grease or oil will damage rubber components and may prevent proper operation.

6-B Maintenance (Refer to Figure 1)

1. Perform steps 1 through 6 of paragraph 6-A FIVE-YEAR INTERNAL INSPECTION.
2. To remove clapper rubber (9):
 - a. Use the appropriate wrenches to loosen and remove button-head socket screw (7), hex nut (11), sealing washer (8), and rubber retainer (10).
 - b. Remove the clapper rubber (9) for inspection. If the clapper rubber shows signs of wear, such as cracking, cuts, or excessively deep grooves where the rubber contacts the water seat, replace the rubber.
3. To re-install clapper rubber (9):
 - a. Place the clapper rubber (9) over the center hub of the rubber retainer (10).
 - b. Position the retainer (10) (with rubber in place) against the clapper (2) as shown in Figure 1.
 - c. Replace and tighten the button-head socket screw (7), sealing washer (8), and hex nut (11). The sealing washer (8) must be located on the top side of the clapper assembly (2) as shown in Figure 1. DO NOT over-tighten.

7. AVAILABILITY

The Viking Check Valve is available through a network of domestic and international distributors. See The Viking Corporation website for closest distributor or contact The Viking Corporation.

8. GUARANTEES

For details of warranty, refer to Viking's current list price schedule or contact Viking directly.



TECHNICAL DATA

**4" CHECK VALVE
MODEL M-2**

The Viking Corporation, 210 N Industrial Park Drive, Hastings MI 49058
 Telephone: 269-945-9501 Technical Services: 877-384-5464 Fax: 269-818-1680 Email: techsvcs@vikingcorp.com
 Visit the Viking website for the latest edition of this technical data page www.vikinggroupinc.com

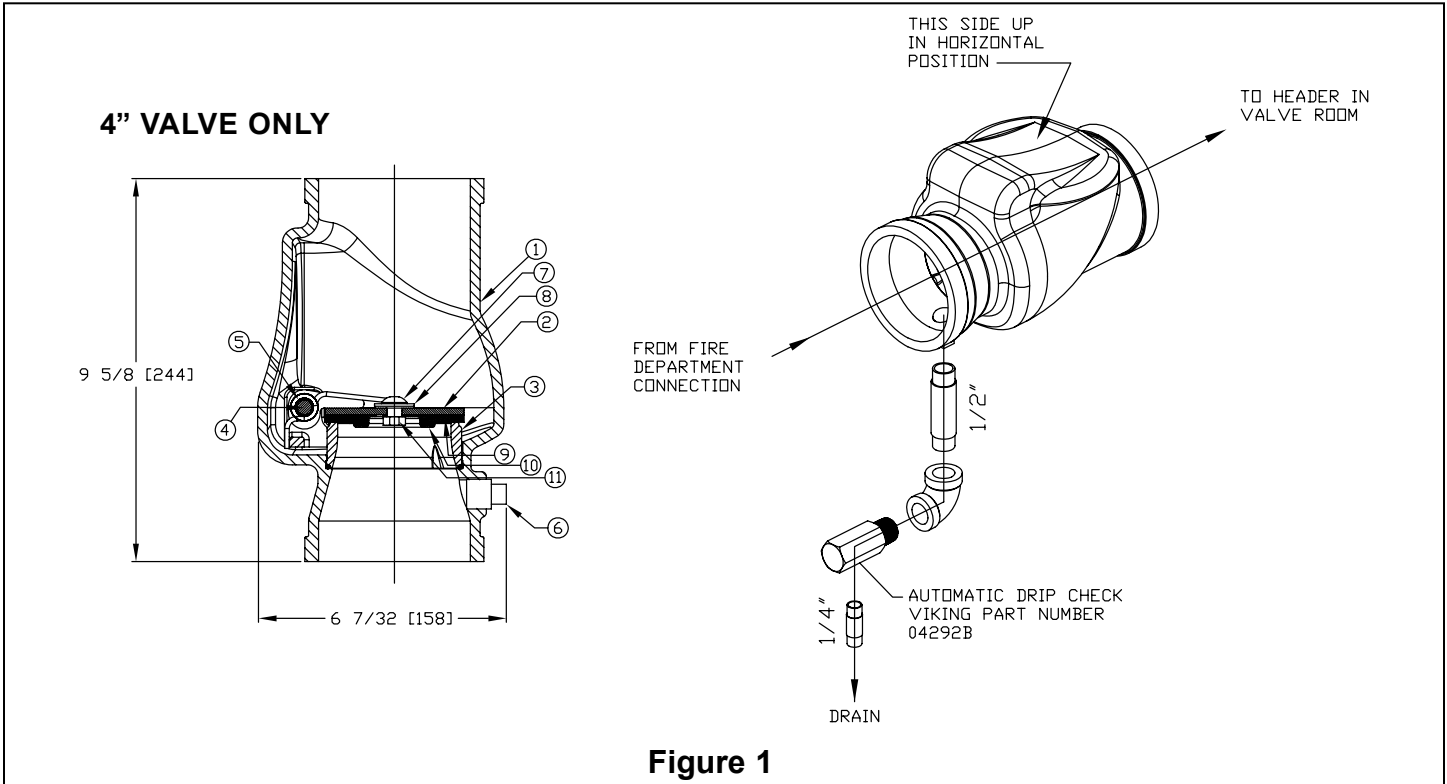

Figure 1

Item No.	Part No.	Description	Material	No. Req'd.
1	--	Body	Ductile Iron, 64-45-12	1
2	--	Clapper Assembly	Stainless Steel, UNS-S30400	1
3	--	Seat	Brass, UNS-C83600	1
4	--	Pin Hinge, Clapper	Stainless Steel, UNS-S30300	1
5	--	Spring	Stainless Steel, UNS-S30200	1
6	--	Plug, 1/2" Galvanized	Galvanized Steel	1
7	*	Screw, Socket Head, 3/8-24 x 1/2"	Stainless Steel, UNS-S30400	1
8	*	Sealing Washer, 3/8"	EPDM & Stainless Steel	1
9	*	Rubber	EPDM	1
10	*	Retainer	Stainless Steel, UNS-S30400	1
11	*	Jam Nut, 3/8"-24	Stainless Steel, UNS-S30400	1
Note: -- Indicates replacement part not available. * Indicates part is available in Sub-Assembly only--see Sub-Assembly list.				
SUB-ASSEMBLY LIST				
7 - 11	13508	Rubber Repair Kit		