



TECHNICAL DATA

4" MODEL G-4000 DRY VALVE RISER ASSEMBLY

The Viking Corporation, 210 N Industrial Park Drive, Hastings MI 49058

Telephone: 269-945-9501 Technical Services: 877-384-5464 Fax: 269-818-1680 Email: techsvcs@vikingcorp.com

1. DESCRIPTION

The Viking 4 inch Model G-4000 Dry Valve Riser Assembly consists of a small profile, light weight, pilot operated valve that is used to separate the water supply from the dry sprinkler piping, which is pressurized with air. The pilot operated valve combines an internal diaphragm assembly that is pressurized closed with priming water, an internal check valve to isolate the sprinkler system piping, and the Model A-1 Differential Valve located on the valve trim that allows the valve to operate upon loss of air pressure. The differential design of the Differential Valve allows an air supply of moderate pressure to control a higher water supply pressure. When the air pressure in the dry pipe system is reduced sufficiently upon the differential valve due to a sprinkler head operation to destroy the pressure differential, the differential valve will open and relieve the priming pressure from the internal diaphragm assembly. The internal diaphragm assembly will compress, which will allow water to pass through the body of the valve and center of the internal check valve, entering the sprinkler system piping. The Viking Model G-4000 Valve is designed to be used with a water flow pressure switch and/or water motor gong. For systems that require an accelerator to increase the speed of water delivery, the Viking Model E-1 Accelerator shall be used.

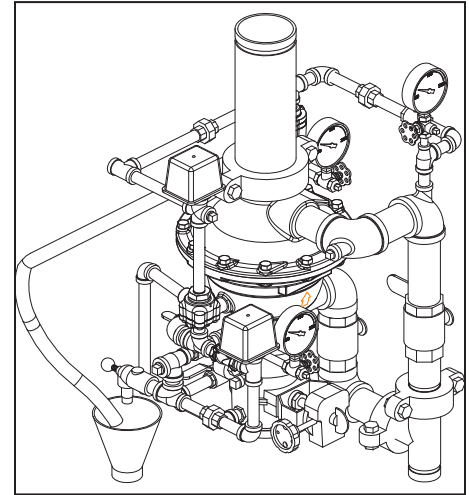

2. LISTING AND APPROVALS

 **UL** US cULus Listed: VPZV



FM Approved: Dry Pipe Valves



WARNING: Cancer and Reproductive Harm-
www.P65Warnings.ca.gov

3. TECHNICAL DATA

Specifications:

Pressure Rating: 250 PSI (17.2 Bar) Water Working Pressure

Factory Hydrostatically Tested to: 500 PSI

Air to water differential: Approximately 5.75 to 1

Friction Loss (Given in feet of Schedule 40 pipe based on Hazen & Williams formula C = 120):

Model G-4000 Dry Valve: 31.2'

12" Section of Pipe: 1'

Water Supply Control Valve: 15'

Model G-4000 Dry Valve C_v Factor: 341

Valve Color: Black

Material Specifications:

Refer to Figure 11.

Ordering Information:

Available since 2008.

Part Number: G-4000 Dry Valve Riser Assembly (See Figure 8) - 15647-1

Accessories:

Model E-1 Accelerator: 08055

Drain Manifold: 15588 (See Figure 9.)

Model LD-1 Anti-Column Device: 14800

G-4000 Dry Valve Riser Assembly with FDC Connection - 15768-1

$$Q = C_v \sqrt{\frac{\Delta P}{S}}$$

Q = Flow

C_v = Flow Factor (GPM/1 PSI ΔP)

ΔP = Pressure Loss through Valve

S = Specific Gravity of Fluid

Viking Technical Data may be found on
The Viking Corporation's Web site at
<http://www.vikinggroupinc.com>.
The Web site may include a more recent
edition of this Technical Data Page.

4. INSTALLATION:

A. General Installation Instructions

- For proper operation and approval, the valve must be installed in the vertical position as trimmed from the factory. DO NOT modify the factory assembled trim except as described in this technical data page.
- Viking recommends installing a 12" section of pipe directly above the G-4000 Dry Valve. Prior to valve maintenance, this section of pipe may be removed to provide clearance for lifting the cover from the body.
- The dry valve must be installed in an area not subject to freezing temperatures or physical damage. If required, provide a valve house (enclosure) with adequate heat around the dry valve and trim. Freezing temperatures and/or excessive pressure will damage the dry valve. When corrosive atmospheres and/or contaminated water supplies are present, it is the owner's responsibility to verify compatibility with the Model G-4000 Dry Valve and associated equipment.
- The Viking E-1 Accelerator should be installed at the location indicated in Figure 1 when required by the installation standard



TECHNICAL DATA

4" MODEL G-4000 DRY VALVE RISER ASSEMBLY

The Viking Corporation, 210 N Industrial Park Drive, Hastings MI 49058
 Telephone: 269-945-9501 Technical Services: 877-384-5464 Fax: 269-818-1680 Email: techsvcs@vikingcorp.com

Table 1 - Pipe Capacity for Sizing Air Compressors

Pipe Diameter		Capacity			
US	International	Schedule 40 (1" to 6") Schedule 30 (8")		Schedule 10	
		Gal / Ft	L / m	Gal / Ft	L / m
		1"	DN25	0.045	0.559
1-1/4"	DN32	0.078	0.969	0.085	1.043
1-1/2"	DN40	0.106	1.316	0.115	1.428
2"	DN50	0.174	2.161	0.190	2.360
2-1/2"	DN65	0.248	3.080	0.283	3.515
3"	DN80	0.383	4.756	0.434	5.390
3-1/2"	DN90	0.513	6.370	0.577	7.165
4"	DN100	0.660	8.196	0.740	9.190
5"	DN125	1.040	12.915	1.144	14.206
6"	DN150	1.501	18.640	1.649	20.477
8"	DN200	2.660	33.032	2.776	30.472

For Metric Units 1 Ft. = 0.3048 M, 1 Gal. = 3.785L

Table 2 - Air Pressure Settings

Maximum Water Pressure		Air Pressure Setting			
		Minimum		Maximum	
PSI	bar	PSI	bar	PSI	bar
50	3.4	22	1.5	27	1.8
75	5.1	26	1.8	31	2.1
100	6.8	30	2.0	35	2.4
125	8.6	34	2.3	39	2.6
150	10.3	38	2.6	43	2.9
175	12.0	42	2.8	47	3.2
200	13.7	45	3.1	50	3.4
225	15.5	49	3.4	54	3.7
250	17.2	53	3.6	58	3.9

Supervisory Pressure Switch should be set 5 PSI (0.34 bar) below air compressor cut out.

or local Authority Having Jurisdiction.

- The optional Model LD-1 Anti-Column Device may be installed to prevent water accumulation above the dry pipe valve.
- The prime line connection shall be made upstream of the water supply control valve using 1/2" or larger pipe.

B. Air Supply Design

Calculating Trip Pressure and Air Compressor Size

To calculate the point where the water pressure will overcome the air pressure and trip the valve, divide the static system water pressure by the differential (Approximately 5.75:1).

Example:

Static Water Pressure = 64 PSI → Trip Point = 64 / 5.75 = 11 PSI.
 The dry valve will trip when the air pressure is reduced to 11 PSI.

NFPA 13 requires the air supply to be capable of filling the entire sprinkler system to its required air pressure within 30 minutes. A common method of sizing an air compressor is to use the following formula:

$$\text{Compressor Size (cfm)} = .012 \times V \text{ (gal)}$$

Where V = System Volume and .012 is a common multiplier that will provide 40 PSI (2.8 bar) in 30 minutes.

The following formula may be used for air pressures different than 40 PSI:

Where:

- V = Volume
- P = Required Air Pressure (Trip Pressure + 15 PSI)
- T = Fill time (typically 30 min.)
- 7.48 = gal. / ft.³
- 14.7 = atmospheric pressure

$$\text{Compressor Size (cfm)} = \frac{V \times P}{7.48 \times 14.7 \times T}$$

Example:

System volume as determined by table 1 = 750 gallons
 System water pressure = 73 PSI
 Required air pressure = (73/5.75) + 15 = 28 PSI

$$\text{Compressor Size (cfm)} = \frac{(750 \times 28)}{7.48 \times 14.7 \times 30} = 6.4 \text{ cfm}$$

Therefore, the compressor shall be capable of providing 7 cfm.

Table 3 - Quick Reference Compressor Size

Compressor Size (HP)	Free Air @ 40 PSI (cfm)	Maximum Gallons in System to Pump to 40 PSI in 30 Minutes
1/6	1.0	90
1/3	2.0	180
1/2	3.1	300
1	5.9	600



TECHNICAL DATA

4" MODEL G-4000 DRY VALVE RISER ASSEMBLY

The Viking Corporation, 210 N Industrial Park Drive, Hastings MI 49058

Telephone: 269-945-9501 Technical Services: 877-384-5464 Fax: 269-818-1680 Email: techsvcs@vikingcorp.com

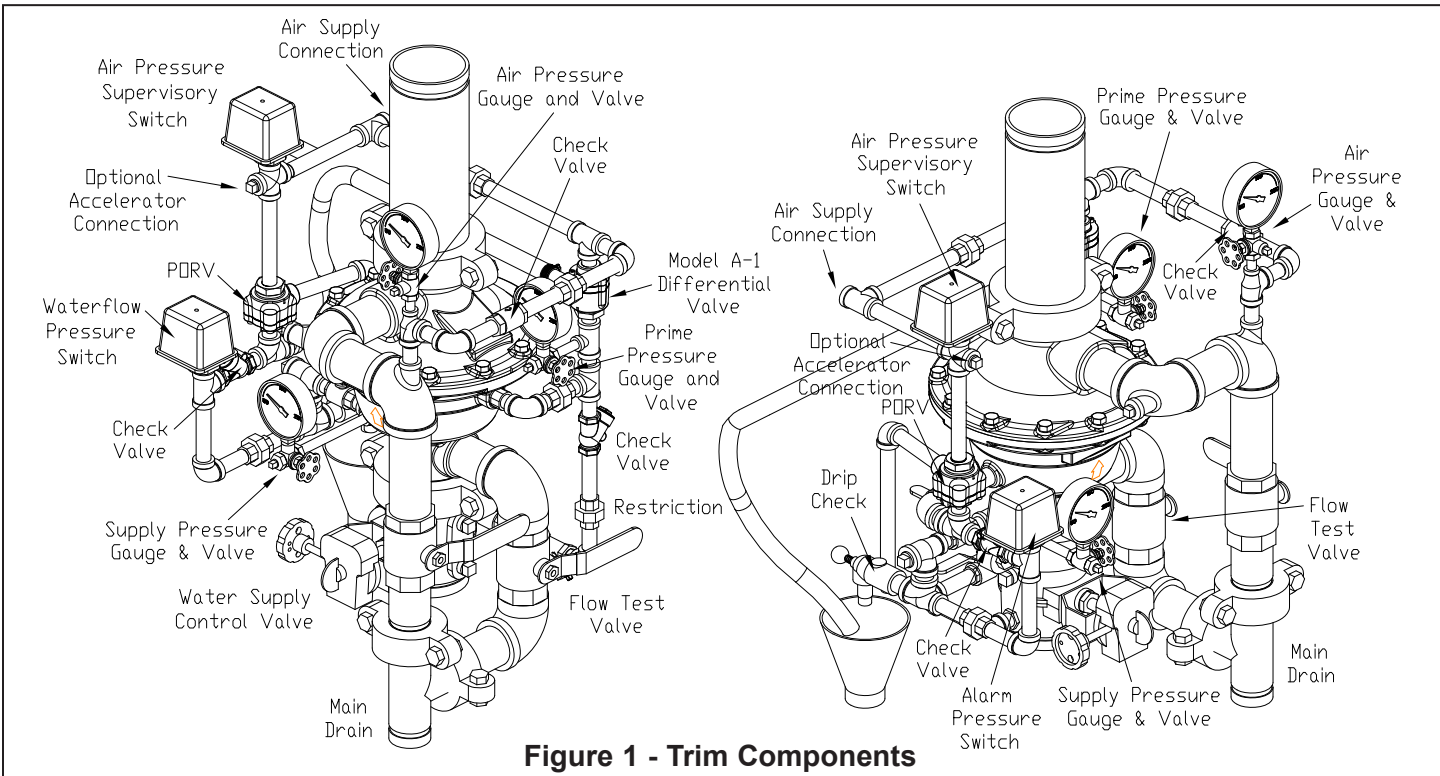

Figure 1 - Trim Components

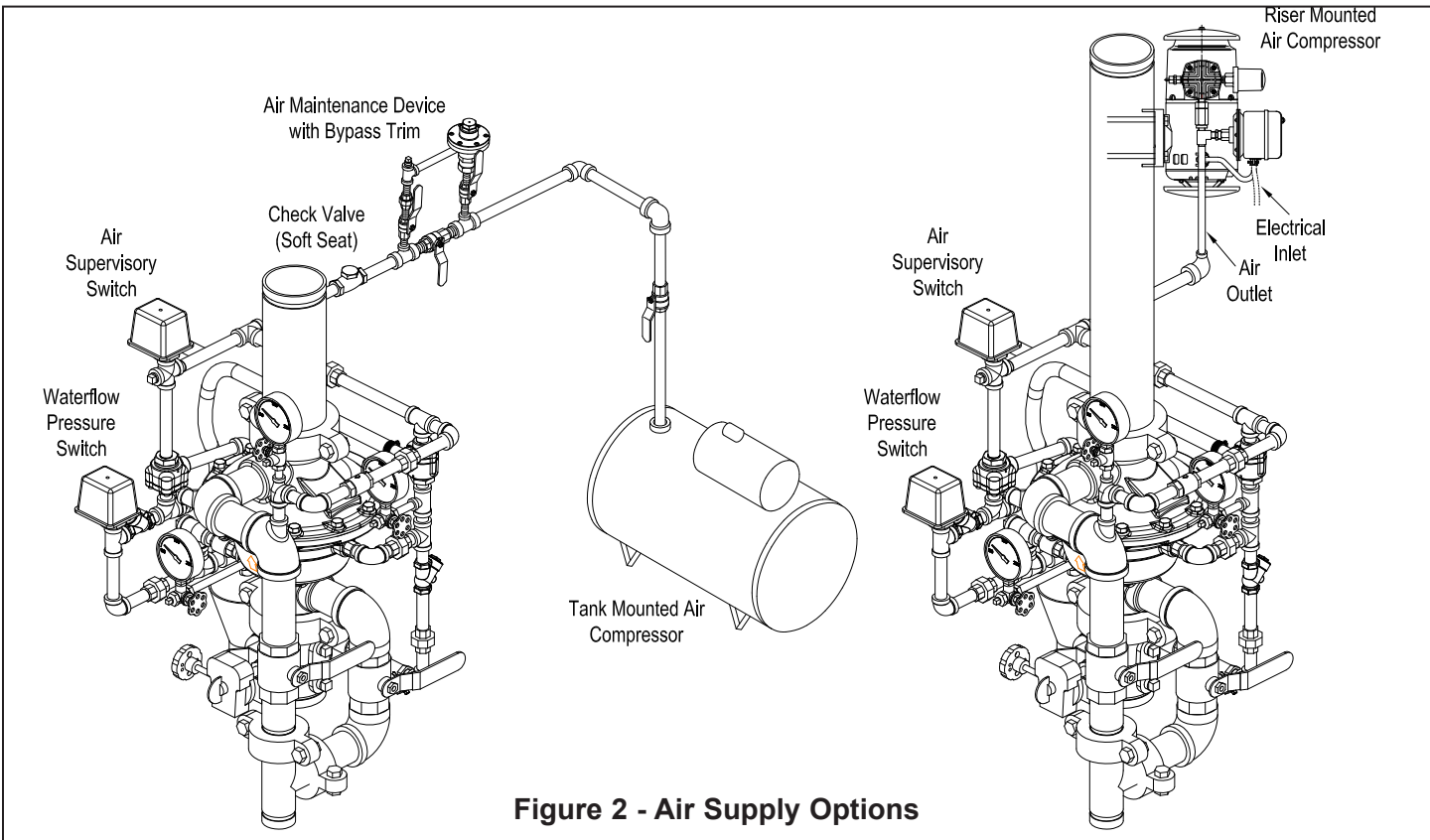

Figure 2 - Air Supply Options



TECHNICAL DATA

4" MODEL G-4000 DRY VALVE RISER ASSEMBLY

The Viking Corporation, 210 N Industrial Park Drive, Hastings MI 49058

Telephone: 269-945-9501 Technical Services: 877-384-5464 Fax: 269-818-1680 Email: techsvcs@vikingcorp.com

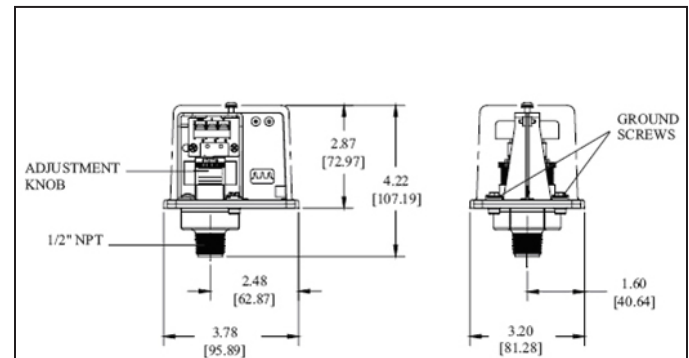
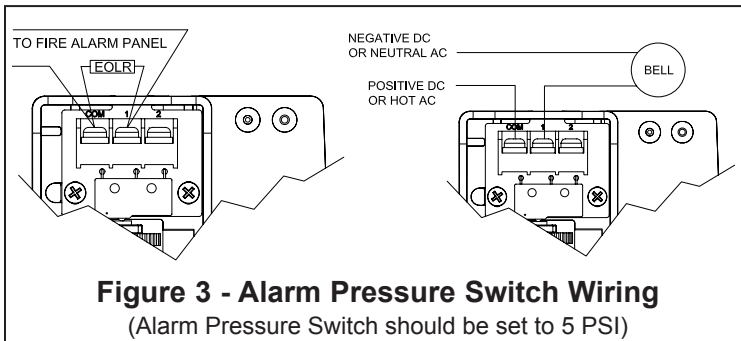

FIELD ADJUSTMENTS:

Alarm Pressure Switch: The operating point of the switch can be adjusted to any point between 4 PSI (0.27 bar) and 8 PSI (0.55 bar) by turning the adjustment knob(s) clockwise to raise the actuation point or counter-clockwise to lower the actuation point.

Air Supervisory Switch: The operating point of the switches can be adjusted to any point between 10 PSI (0.7 bar) and 60 PSI (4.1 bar) by turning the adjustment knob(s) clockwise to raise the actuation point or counter-clockwise to lower the actuation point. The high and low switches are adjusted independently.

Figure 5 - Pressure Adjustment

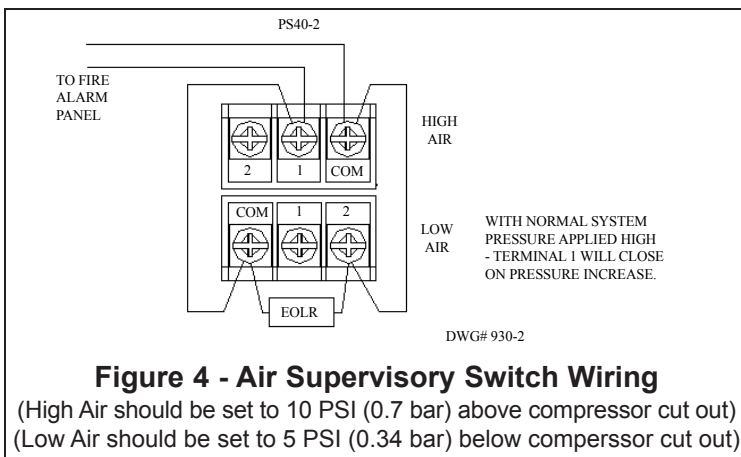

C. Air Supply Installation

1. Install the required air supply as described in Viking technical data page 105a-e. The size of the compressor and amount of air required should be determined in accordance with Table 1. The air or nitrogen supply to the dry pipe system must be clean, dry, and oil free.
2. Automatic air supplies must be regulated, restricted, and from a continuous source. A Viking Air Maintenance Device should be installed on each system equipped with a tank mounted compressor, plant air or nitrogen. For riser mounted compressors with a capacity less than 5.5 ft³/min at 10 PSI, NFPA 13 does not require an air maintenance device. In addition, the use of an air maintenance device with riser mounted compressors can lead to compressor "short cycling". Viking always recommends that a tank mounted compressor with air maintenance device be used. This can become critical when accelerators are installed on the system.

D. Pressure Switch Wiring;

Wire the Alarm Pressure Switch (PS10) and Air Supervisory Switch (PS40), and adjust pressure settings as shown in Figures 3 - 5.

E. Air Leakage Test:

Perform air leakage test at 40 PSI for 24 hours per NFPA 13. If pressure loss of 1.5 PSI or greater occurs, repair leaks.

F. Hydrostatic Test:

The Dry System, including sprinkler piping and sprinklers shall be hydrostatically tested at 200 PSI and maintained for 2 hours, in accordance with NFPA 13. Systems normally subjected to working system pressures in excess of 150 PSI shall be tested at a pressure of 50 PSI in excess of system working pressure.

G. Placing the Valve in Service:

When the dry pipe system is ready to be placed in service, verify that all equipment is adequately heated and protected to prevent freezing and physical damage.

1. Verify that the water supply main control valve supplying the dry valve is closed.
2. Close the prime valve.
3. Open the main drain valve.
4. Drain all water from the dry pipe system. If the system has operated, or if water has entered the system, allow enough time to completely drain the system.
5. Close the main drain valve.



TECHNICAL DATA

4" MODEL G-4000 DRY VALVE RISER ASSEMBLY

The Viking Corporation, 210 N Industrial Park Drive, Hastings MI 49058

Telephone: 269-945-9501 Technical Services: 877-384-5464 Fax: 269-818-1680 Email: techsvcs@vikingcorp.com

6. Open the flow test valve.
7. Establish air pressure on the system.
8. When air pressure has been established, open the priming valve. Prime water pressure will enter and expand the valve's internal diaphragm assembly onto the valve seat, effectively closing the valve. Verify prime pressure has been established on the prime pressure gauge.
9. Verify that no water flows from the drip check when the plunger is pushed.
10. When the priming pressure has been verified as being established, slowly open the water supply control valve (not shown).
11. When flow is developed from the flow test valve, CLOSE the flow test valve.
12. Fully open the water supply main control valve.
13. Secure all valves in their normal operating position.
14. Notify Authorities Having Jurisdiction and those in the affected area that the system is in service.
15. The system is now fully operational.

H. Operational Test:

An operational test shall be performed on the system in accordance with NFPA 13 as follows:

1. Open the instector's test connection.
2. Record the time to trip the valve.
3. Record the time for water delivery to the inspector's test connection.

5. OPERATION

A. In the Set Position:

When air pressure is introduced into the sprinkler piping, the sensing end of the differential valve is pressurized. This closes the differential valve, preventing prime water from escaping the prime chamber of the dry pipe valve. When prime water enters the prime chamber, the rolling diaphragm is pressurized, causing it to expand downward onto the water seat.

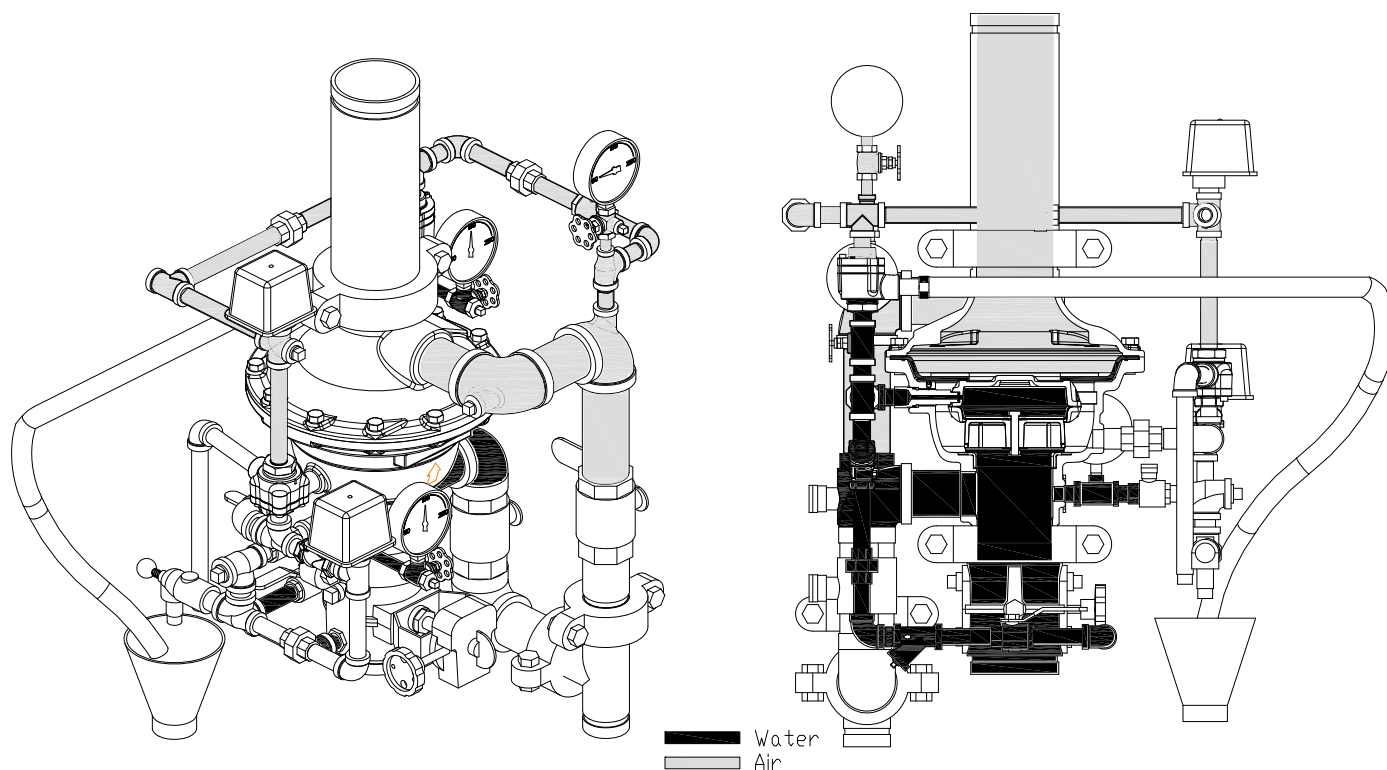

Figure 6 - Set Position



TECHNICAL DATA

4" MODEL G-4000 DRY VALVE RISER ASSEMBLY

The Viking Corporation, 210 N Industrial Park Drive, Hastings MI 49058

Telephone: 269-945-9501 Technical Services: 877-384-5464 Fax: 269-818-1680 Email: techsvcs@vikingcorp.com

B. Loss of System Air Pressure:

When a sprinkler operates or air pressure is lost, the sensing end of the differential valve loses pressure and the differential valve opens. Prime water is drained from the prime chamber, causing the dry pipe valve to open, filling the sprinkler piping with water. Water from the intermediate chamber of the dry pipe valve pressurizes the sensing end of the D-3 PORV, causing the PORV to open. The open PORV vents air pressure from the air supply, preventing the differential valve from closing and re-establishing prime pressure.

6. INSPECTIONS, TESTS & MAINTENANCE

It is imperative that the system be inspected and tested on a regular basis. The frequency of the inspections may vary due to contaminated water supplies, corrosive water supplies, corrosive atmospheres, as well as the condition of the air supply to the system. For minimum testing and inspection requirements, refer to NFPA 25. In addition, the Authority Having Jurisdiction may have additional testing, and inspection requirements that must be followed. Viking does not require internal inspection of the valve as part of routine inspection and testing. Internal maintenance is generally only required for valve repairs and internal component replacement.

Maintenance of the Model G-4000 Dry Valve shall be conducted in accordance with the instructions in section 6.III.

WARNING: DO NOT SEPARATE THE COVER AND BODY SECTIONS UNLESS THE VALVE IS LEAKING.

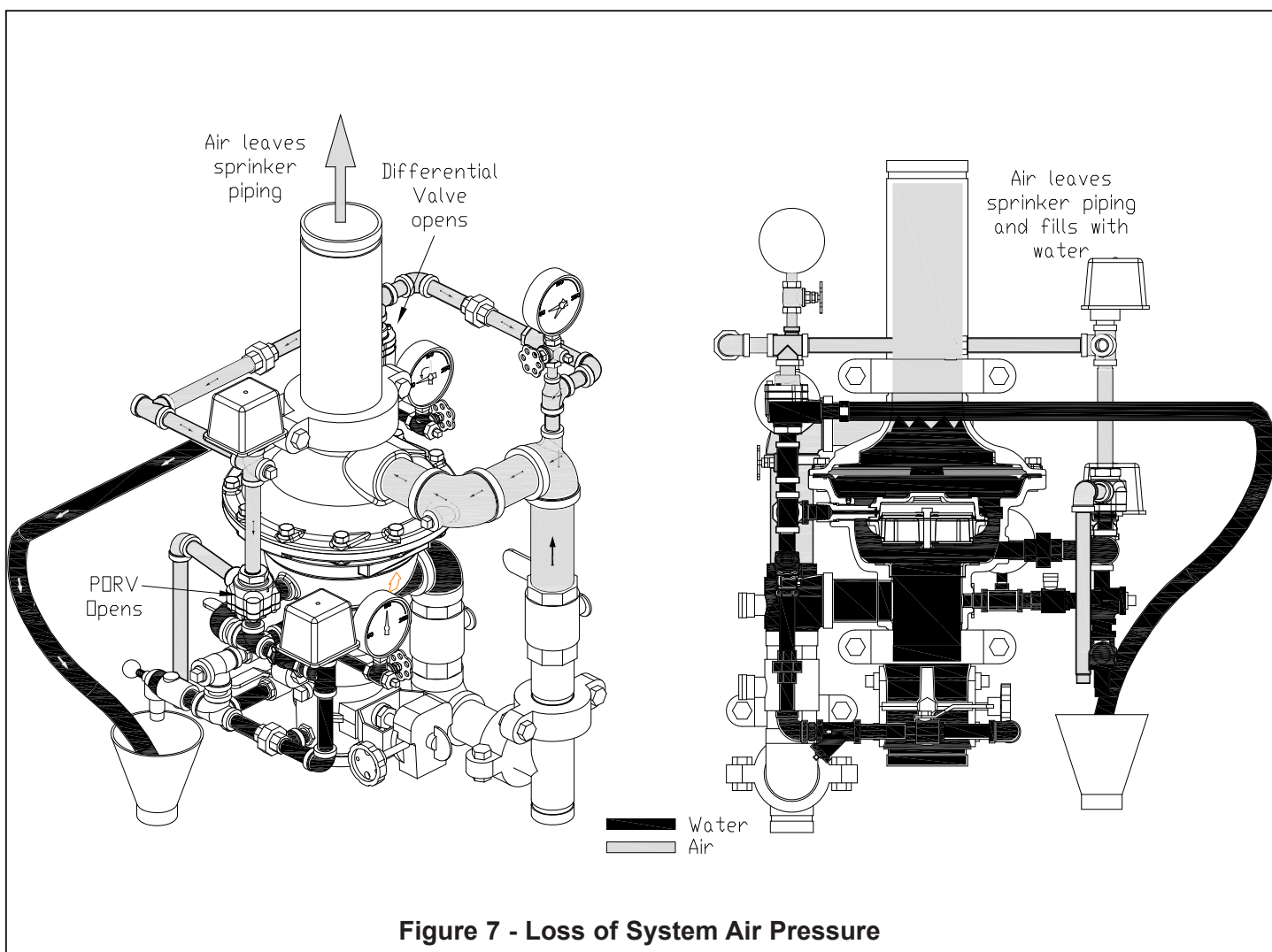

Figure 7 - Loss of System Air Pressure



TECHNICAL DATA

4" MODEL G-4000 DRY VALVE RISER ASSEMBLY

The Viking Corporation, 210 N Industrial Park Drive, Hastings MI 49058

Telephone: 269-945-9501 Technical Services: 877-384-5464 Fax: 269-818-1680 Email: techsvcs@vikingcorp.com

I. INSPECTION

Weekly inspection is recommended. If the system is equipped with a low air (or nitrogen) alarm, monthly inspections may be adequate.

1. Check pressure gauges located on the supply side and system side of the dry valve. Verify that the proper ratio of air (or nitrogen) pressure to water supply pressure is being maintained. Refer to Table 1.
2. Verify that the intermediate chamber of the dry valve is free of water. No water should flow from the drip check when the plunger is pushed.
3. Verify that there is no air coming out of the 1/2" outlet of the PORV.
4. If equipped with a Viking accelerator:
 - a. Check the air pressure gauge located on the top of the accelerator. Air pressure in the upper chamber of the accelerator should equal the pneumatic pressure maintained in the system.
5. Verify that the water supply main control valve is open and all trim valves are in their normal operating position.
6. Check for signs of mechanical damage and/or corrosive activity. If detected, perform maintenance as required or, if necessary, replace the device.
7. Verify that dry valve and trim are adequately heated and protected from freezing and physical damage.

II. TESTS

Quarterly Tests

A. Water Flow Alarm Test

Quarterly testing of water flow alarms is recommended and may be required by the Authority Having Jurisdiction.

1. Notify the Authority Having Jurisdiction and those in the area affected by the test.
2. To test the local electric alarm (if provided) and/or mechanical water motor gong (if provided), OPEN the alarm test valve in the dry valve trim.
 - a. Electric alarm pressure switches should activate.
 - b. Electric local alarms should be audible.
 - c. The local water motor gong should be audible.
 - d. Verify that remote station alarm signals (if provided) were received.
3. When testing is complete, close the alarm test valve.
4. Verify:
 - a. All local alarms stop sounding and alarm panels (if provided) reset.
 - b. All remote station alarms reset.
 - c. All supply piping to water motor properly drains.
5. Verify that the alarm test valve is CLOSED.
6. Verify that the intermediate chamber of the dry valve is free of water. No water should flow from the drip check when the plunger is pushed.
7. Notify the Authority Having Jurisdiction and those in the affected area that testing is complete.

B. Main Drain Test

Quarterly performance of the Main Drain Test is recommended and may be required by Authorities Having Jurisdiction to verify integrity of the water supply.

1. Notify the Authority Having Jurisdiction and those in the area affected by the test.
2. Record pressure reading from the water supply pressure gauge.
3. Verify that the intermediate chamber of the dry valve is free of water. No water should flow from the drip check when the plunger is pushed.
4. Verify that there is no air coming out of the 1/2" outlet of the PORV.
5. Verify that the dry pipe system is pressurized at or above the minimum pressure recommended in Table 2 for the water supply pressure available.
6. Fully OPEN the main drain valve located on the base of the dry valve.
7. When a full flow is developed from the main drain, record the residual pressure from the water supply pressure gauge.
8. When the test is complete, SLOWLY CLOSE the main drain.
9. Compare test results with previous flow information. If deterioration of the water supply is detected, take appropriate steps to restore adequate water supply.
10. Verify that normal water supply pressure and system pneumatic pressure have been restored, and that all alarm devices and valves are secured in normal operating position.
11. Notify the Authority Having Jurisdiction that the test is complete. Record and/or provide notification of test results as required by the Authority Having Jurisdiction.



TECHNICAL DATA

4" MODEL G-4000 DRY VALVE RISER ASSEMBLY

The Viking Corporation, 210 N Industrial Park Drive, Hastings MI 49058

Telephone: 269-945-9501 Technical Services: 877-384-5464 Fax: 269-818-1680 Email: techsvcs@vikingcorp.com

C. Low Air Alarm Test

Quarterly testing of low air alarms is recommended.

1. Notify the Authority Having Jurisdiction and those in the area affected by the test.
2. Close the water supply main control valve supplying the dry valve.
3. Close the priming valve.
4. Open the flow test valve (located on the inlet of the dry valve).
5. If the dry valve being tested is equipped with a Viking Model E-1 Accelerator, performing step 6 of this test will cause the accelerator to operate. A burst of air from the vent in the bottom of the accelerator will indicate operation of the accelerator. However, with the water supply main control valve CLOSED and the flow test valve OPEN, operation of the accelerator should not trip the dry valve.
6. Low Air Alarm Test:
 - a. Verify that the water supply main control valve is closed and the flow test valve is open.
 - b. Gradually open the main drain valve on top of the dry valve to simulate operation of the dry system. Observe and record the pressure at which the low air alarm operates.
7. Close the main drain valve.
8. Perform steps 1 through 15 of section 4.G - Placing the valve in Service.

Trip Tests

Partial Flow Trip Tests are conducted with the water supply main control valve partially closed to minimize the amount of water entering the system during the test. Performance of a Partial Flow Trip Test is recommended during warm weather at least annually except when a Full Flow Trip Test is conducted. Partial Flow Trip Tests may verify operation of equipment and devices but do not simulate operation of the system in fire conditions.

Full Flow Trip Tests are conducted with the water supply main control valve fully open. The dry valve is operated by opening the system test valve to simulate the opening of a sprinkler in fire conditions. When the dry valve operates, the sprinkler piping will be flooded with water.

Performance of a Full Flow Trip Test is recommended during warm weather at least once every three years. More frequent testing may be required by the Authority Having Jurisdiction.

A. Full Flow Trip Test

1. Notify the Authority Having Jurisdiction and those in the area affected by the test.
2. Fully open the flow test valve (located on the base of the dry valve) to flush away any accumulation of foreign material.
3. Close the flow test valve.
4. Record water supply pressure and system air pressure.
5. Open the remote system test valve to simulate operation of the dry system. Record:
 - a. Elapsed time from opening of the test valve to operation of the dry valve. System pressure when the dry valve operated.
 - b. Elapsed time from opening of the test valve to development of full flow of water from the system test connection.
 - c. Any other information required by the Authority Having Jurisdiction.
6. Verify that alarms operate properly.
7. Allow water to flow from the system test connection until it appears clear and clean.
8. When test is complete, close the water supply main control valve.
9. Perform steps 1 through 15 of section 4.G - Placing the Valve in Service.
10. Verify that the water supply main control valve is open, and all other valves are in their normal operating position.

B. Partial Flow Trip Test

1. Notify the Authority Having Jurisdiction and those in the area affected by the test.
2. Record water supply pressure and system air pressure.
3. Fully open the flow test valve (located on the base of the dry valve) to flush away any accumulation of foreign material.
4. CLOSE the water supply main control valve as far as possible while maintaining full flow from the flow test valve. CLOSE the flow test valve.
5. Open the main drain valve to simulate operation of the system.
6. Note (for records) water supply pressure and system air pressure when the dry valve operates.
7. CLOSE the water supply main control valve and OPEN the main drain IMMEDIATELY, when test is complete.
8. Perform steps 1 through 15 of section 4.B - Placing the Valve in Service.
9. Verify that the water supply main control valve is open, all other valves are in their normal operating position.

III. MAINTENANCE

1. Close the water supply main control valve, placing the system out of service.
2. Open the flow test valve located in the base of the dry valve.
3. Close the air (or nitrogen) supply to the dry system piping.



TECHNICAL DATA

4" MODEL G-4000 DRY VALVE RISER ASSEMBLY

The Viking Corporation, 210 N Industrial Park Drive, Hastings MI 49058

Telephone: 269-945-9501 Technical Services: 877-384-5464 Fax: 269-818-1680 Email: techsvcs@vikingcorp.com

4. Close the priming valve.
5. Relieve all pressure from the dry system piping. If the system has operated, open main drain valve to allow the system to drain completely.
6. Confirm that all three pressure gauges read zero.

A. Removing the Cover from the Body

1. Remove the 4" grooved coupling from the top of the dry valve.
2. Remove the section of pipe directly above the dry valve, if provided.
3. Open both of the 1/2" unions on the air supply line.
4. Remove the 2" coupling below the main drain, if provided.
5. Remove the 12 cover screws.
6. The cover and trim that is still connected may now be removed from the valve body. (It may be necessary to pry the valve open as the diaphragm may bond itself to the cover and body over time.)

B. Removing / Replacing the Check Diaphragm

1. The check diaphragm may be lifted from the valve body.
2. If necessary, replace the check diaphragm.

C. Inspecting the Prime Chamber and Coupling for leaks

If desired, it is possible to set the G-4000 Dry Pipe Valve and inspect for leaks with the cover removed.

1. Remove the A-1 Differential Valve from the prime line and temporarily install a pipe plug.
2. Slowly open the prime valve. Confirm that the valve is primed by reading the prime pressure gauge.
3. With prime water established, partially open the main water supply control valve.
4. Visually inspect the inside of the dry pipe valve for leaks.
5. Close the main water supply control valve.

D. Removing / Replacing the Prime Coupling

1. Open the 1/2" union on the prime line.
2. Using a wrench on the flats of the coupling, remove the coupling from the valve body.
3. Inspect the coupling and 2 O-rings. Replace if necessary.

E. Removing / Replacing the Prime Chamber Assembly

1. The prime chamber assembly is now held in place by two flanges on the outside diameter of the assembly. Slide the prime chamber assembly toward the prime line and remove from the body.
2. Inspect and replace if necessary.
3. Inspect the seat. The seat should be clean and free of foreign material. If the Seat is damaged, the G-4000 Dry Pipe Valve must be replaced.

F. Re-Assembling the Valve

1. Verify that the prime piston is fully extended downward.
2. Place the prime chamber assembly in the valve body. Make sure the two flanges are positioned in the groove.
3. Thread the prime coupling into the valve body. Make sure the end of the prime coupling is inserted into the prime chamber assembly.
4. Lay the check diaphragm into the valve body.
5. Position the cover onto the valve body, and install and tighten the cover screws.
6. Re-install any trim that was removed.
7. Place the valve in service by following the steps in Section 4.G.

7. AVAILABILITY

The Viking Model G-4000 Dry Valve Riser Assembly is available through a network of domestic and international distributors. See the Viking Corp. Web site for closest distributor or contact The Viking Corporation.



TECHNICAL DATA

4" MODEL G-4000 DRY VALVE RISER ASSEMBLY

The Viking Corporation, 210 N Industrial Park Drive, Hastings MI 49058

Telephone: 269-945-9501 Technical Services: 877-384-5464 Fax: 269-818-1680 Email: techsvcs@vikingcorp.com

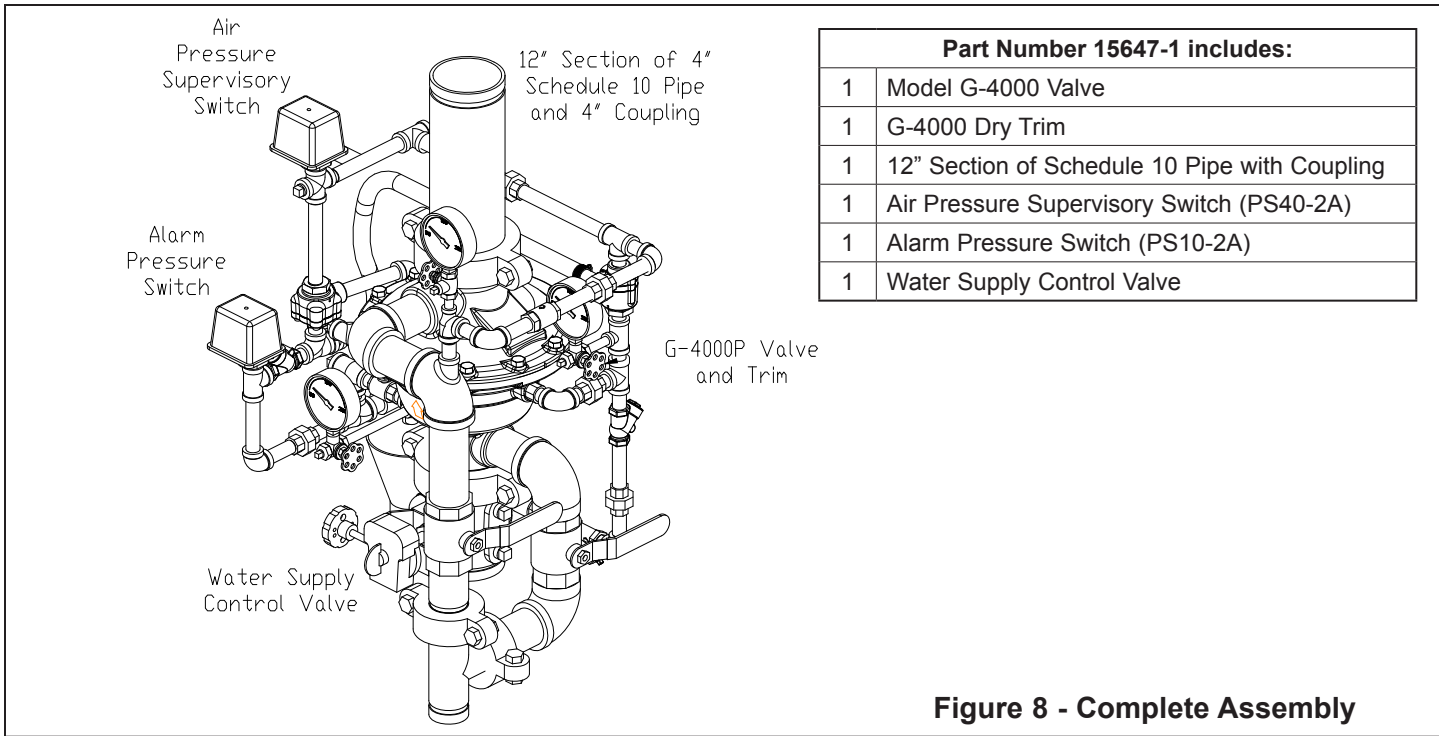

Figure 8 - Complete Assembly

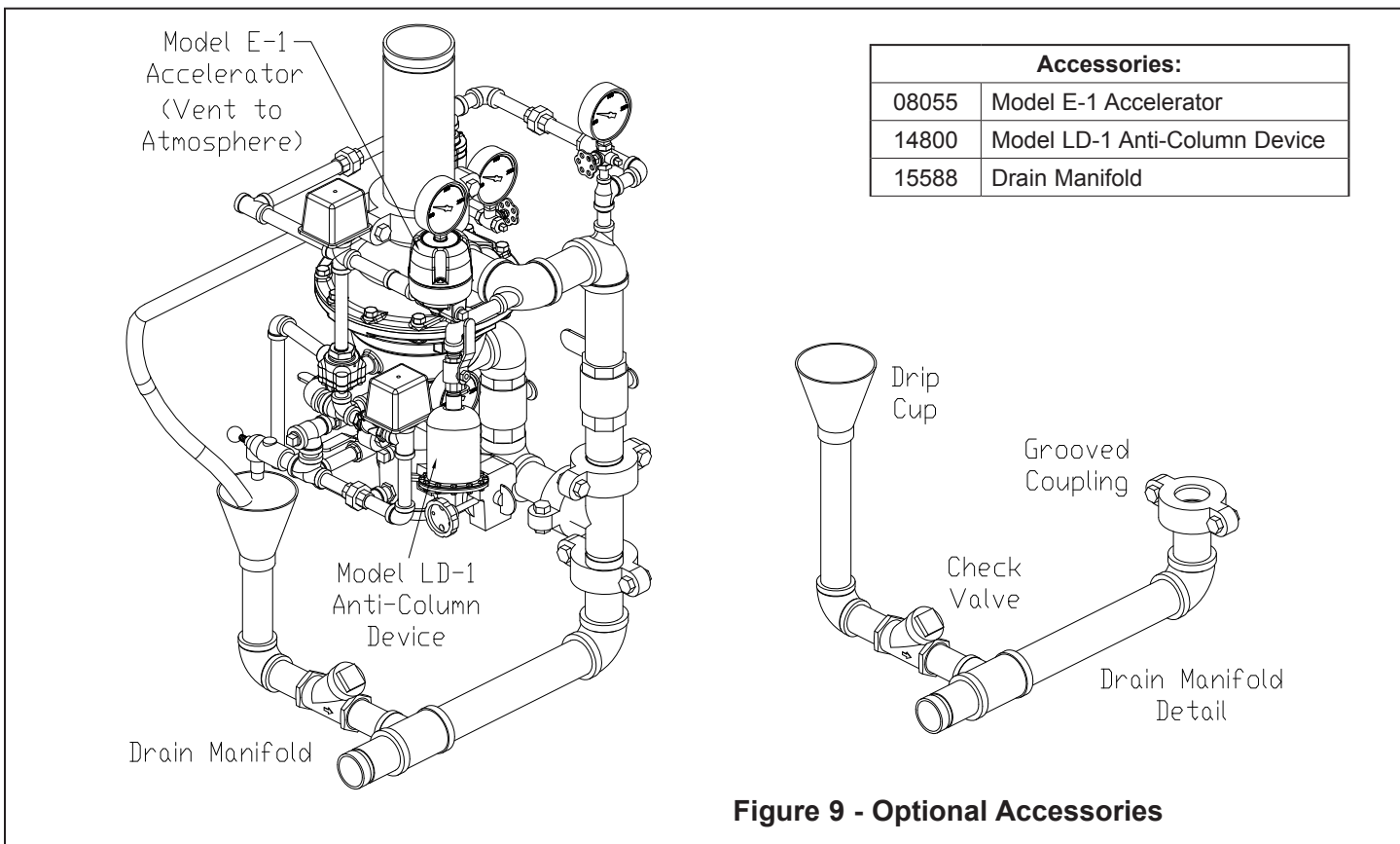

Figure 9 - Optional Accessories



TECHNICAL DATA

4" MODEL G-4000 DRY VALVE RISER ASSEMBLY

The Viking Corporation, 210 N Industrial Park Drive, Hastings MI 49058

Telephone: 269-945-9501 Technical Services: 877-384-5464 Fax: 269-818-1680 Email: techsvcs@vikingcorp.com

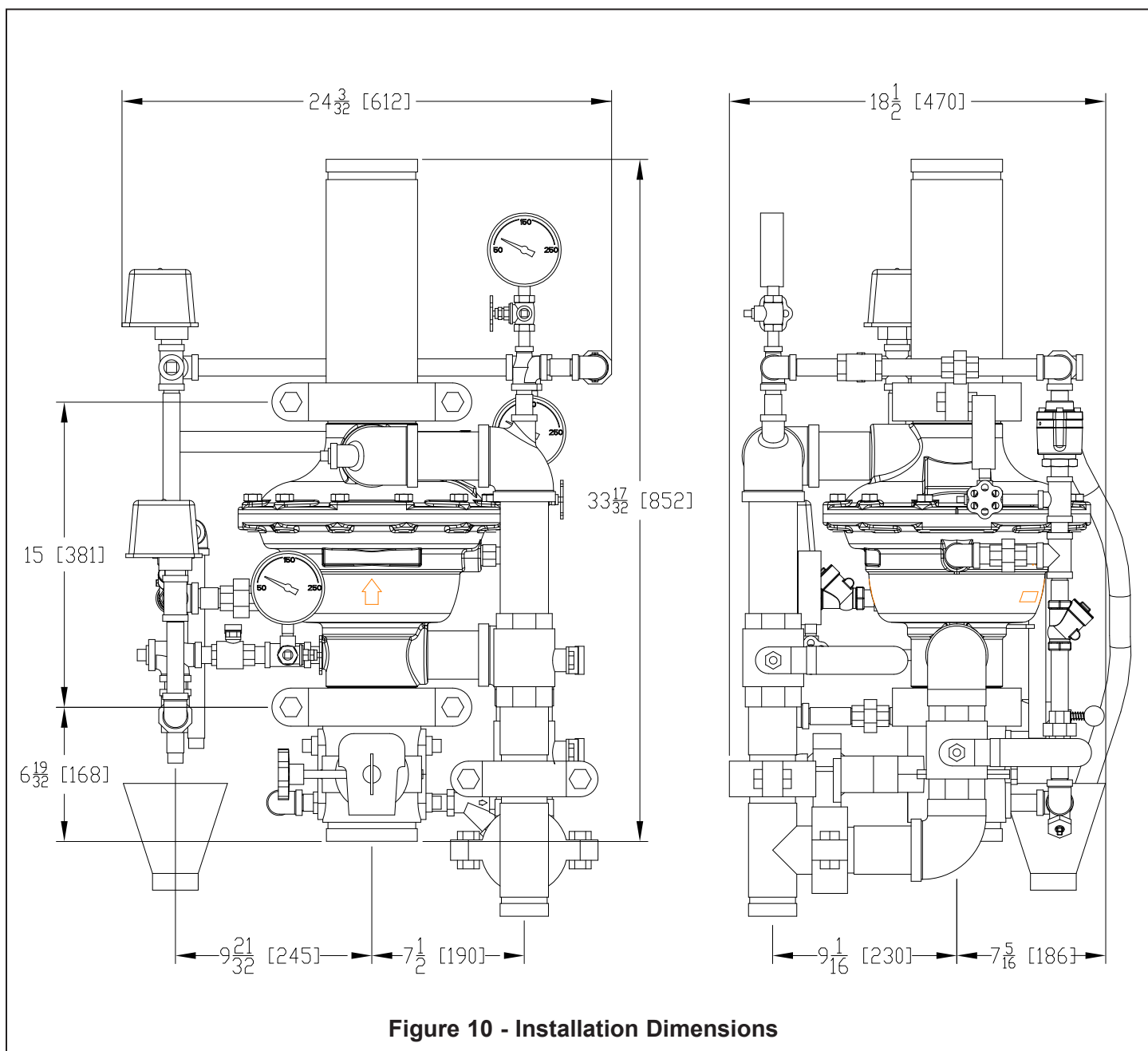



TECHNICAL DATA

4" MODEL G-4000 DRY VALVE RISER ASSEMBLY

The Viking Corporation, 210 N Industrial Park Drive, Hastings MI 49058

Telephone: 269-945-9501 Technical Services: 877-384-5464 Fax: 269-818-1680 Email: techsvcs@vikingcorp.com

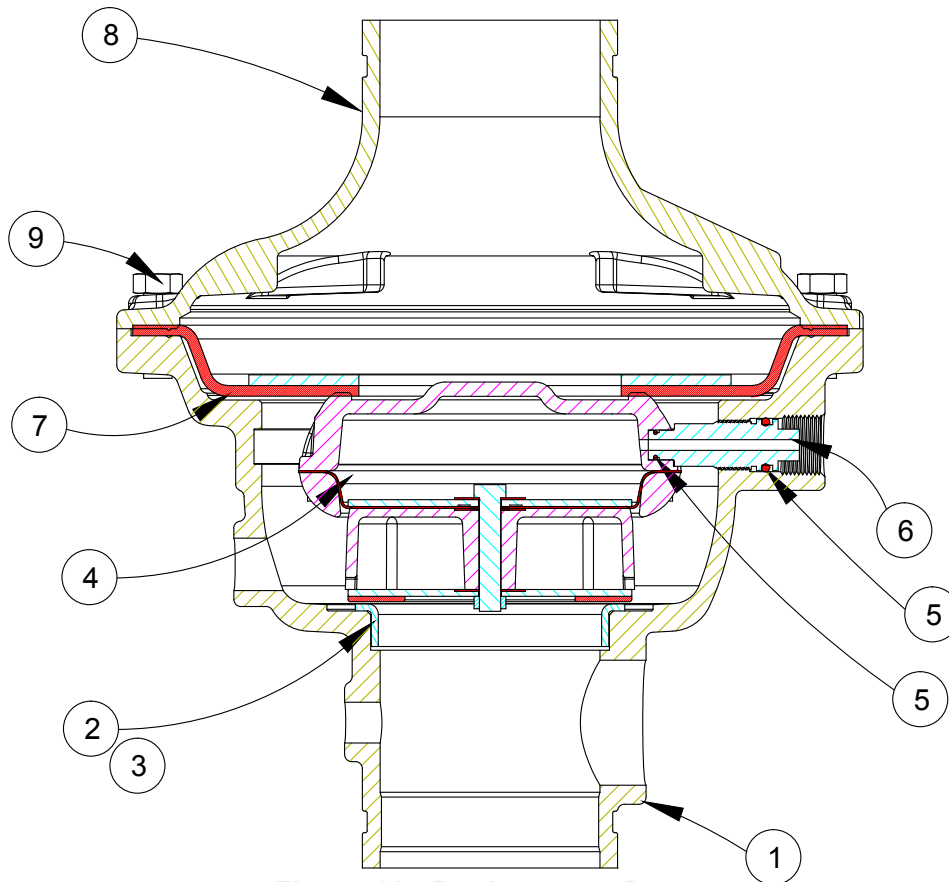

Figure 11 - Replacement Parts

Item Number	Part Number	Description	Material	Number Required
1	--	Body	65-45-12 Ductile Iron	1
2	--	Seat	UNS-C11000 Copper or UNS-S30400 Stainless Steel	1
3	--	Anarobic Adhesive	--	1
4	16280	Prime Chamber Assembly	Brass, EPDM, Nitrile, 304 Stainless Steel, Bronze Alloy	1
5	*	O-Rings	EPDM and Nitrile	2**
6	18306	Coupling	UNS S17400 Stainless Steel	1
7	14941	Check Diaphragm	EPDM	1
8	--	Cover	65-45-12 Ductile Iron	1
9	08083	1/2-13 x 1-1/2" HHS	UNS-S30400 Stainless Steel	12
10	--	Data Plate	Aluminum	2
11	--	Tack	Alloy Carbon Steel	4

-- Replacement part not available.

Sub-Assembly

5	19145	O-Ring Replacement Kit (**Refer to O-Ring Replacement Bulletin Form No. F_120311 for instructions.)		
---	-------	---	--	--



TECHNICAL DATA

4" MODEL G-4000 DRY VALVE RISER ASSEMBLY

The Viking Corporation, 210 N Industrial Park Drive, Hastings MI 49058

Telephone: 269-945-9501 Technical Services: 877-384-5464 Fax: 269-818-1680 Email: techsvcs@vikingcorp.com

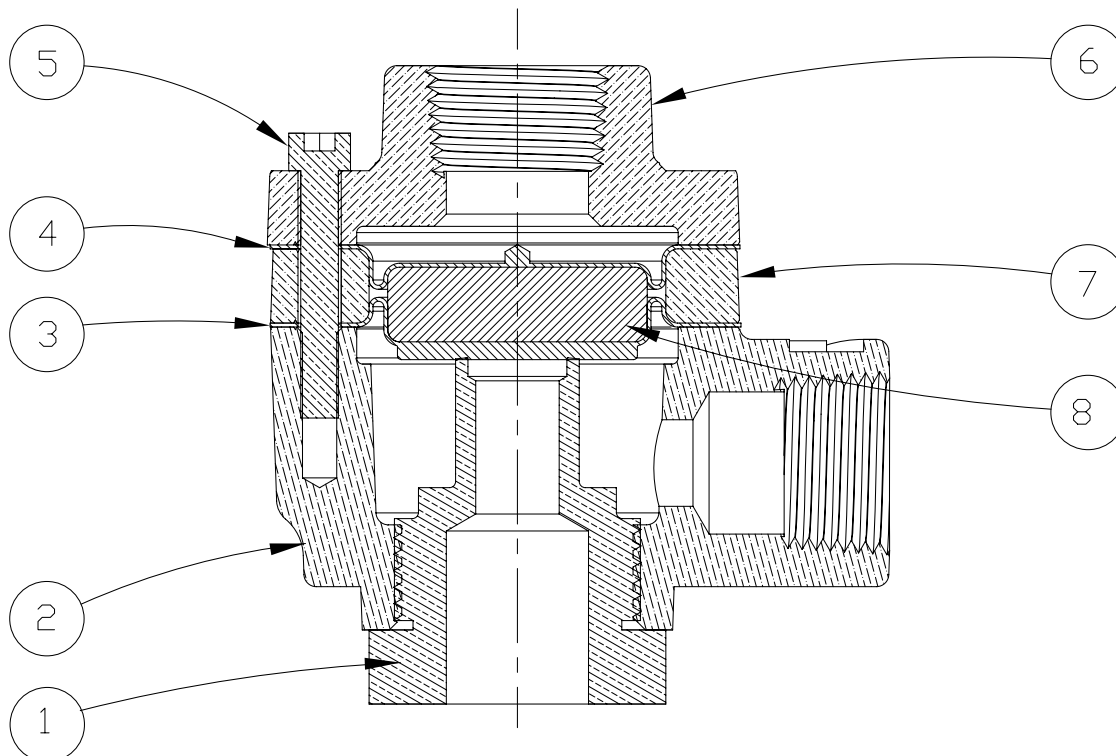

Figure 12 - Model A-1 Differential Valve

Item Number	Part Number	Description	Material	Number Required
1	15459	Seat	Brass UNS-C36000	1
2	--	Body	Brass UNS-C84400	1
3	14948	Diaphragm	Polyester Fabric and EPDM Elastomer	1
4	04735A	Upper Diaphragm	Bellofram	1
5	12470	Screw, #10-24 x 1-1/4" Long	Steel, Zinc Coated	3
6	--	Cover	Brass UNS-C84400	1
7	--	Spacer	Brass UNS-C84400	1
8	04736A	Piston	Polycarbonate	1
-- Replacement part not available.				
1-8	15461	Replacement A-1 Differential Valve		
3-5, 8	15763	Maintenance Kit		