

SFFECO

FIRE PUMPS



- ☞ *Foam Systems*
- ☞ *Deluge Systems*
- ☞ *Hydrant Systems*
- ☞ *Sprinkler Systems*
- ☞ *Hose Reel Systems*
- ☞ *Hose Rack Systems*



المصنع السعودي لأجهزة الإطفاء
SAUDI FACTORY FOR FIRE EQUIPMENT

DECADES
EXCELLENCE

COMPANY PROFILE



SFFECO (Saudi Factory for Fire Equipment Est.) an ISO 9000:2008 Certified Factory with its Head Quarter at Riyadh, K.S.A, is one of the largest Fire Fighting Equipment Manufacturing Facilities in the Region. It was established in 1983 with state of the art manufacturing facility for a wide range of fire fighting equipments.

SFFECO With over 750 Employees & Highly Qualified team of Professional Engineers can supply a wide spectrum of Fire Fighting Products, along with its own Comprehensive Designs, Installations, & Commissioning, besides to the necessary Consultancy Services in the Field of Fire Fighting as per the National & International Standards & Codes.

SFFECO Reputation for Quality & Reliability has made its trusted name through out G.C.C & other Countries Worldwide for its Products. SFFECO is not only rich in History & Quality, but on continuous improvement, & development of product features.

SFFECO is a member of National Fire Protection Association (NFPA), British Standards Institution (BSI), Fire Protection Association (FPA), as well as Approved Vendor to Many Governmental, & Semi - Governmental Sectors in G.C.C.

SFFECO Vision to develop with Wisdom & Prosper in Harmony, and continue to be the leader in the Fire Protection industry providing excellent service & superior products for many years to come.

SYSTEM TECHNOLOGY

SFFECO Fire Pump System Technology

Being Local Specialist Manufacture gives **SFFECO** the Opportunity and Privilege to Develop an Innovative Pump Assembly Units, and Tailor Pump Packages to clients' specific needs, Moreover SFFECO has assured supplying Pump units comply with Local Authority Requirements, as well as NFPA - 20 Selection and Operation Procedures.

SFFECO Highly Skilled Team has over 25 years Combined Experience in Design, Assembly, and Pump Packages Testing.... Succeeded developing the "Excel SERIES" Pre- Fabricated Fire Pump Skids, where this developed technology assure providing Compact Design Pump Sets, easily to Handle ,Install,& Maintain ,where all Pumping Elements, Drivers, Controllers are all skid Mounted, Pre-piped, Wired, & Factory tested .

Excel Series Standard Packages included wide variety of Fire Pump Units start from 50 GPM size up to 1500 GPM, with pressure range from 6 bars up to 12 bars. This wide Range of Pumping & Head Characteristics has Made **Excel Series** suitable in various market sectors such as; Government Buildings, Commercial and Residential Towers, Ware houses, Factories etc.

Excel Series is the right Choice for most of the Fire Fighting Applications;

- **Fire Hose Cabinet Systems.**
- **Automatic Sprinkler Systems.**
- **Deluge Systems.**
- **Hydrant Systems.**
- **Foam Systems.**

PACKAGE ASSEMBLY MODELS

"Excel Series" Packages Offers Completed Skid Mounted Unit including High quality Horizontal End Suction / Split case Pumps that coupled with Heavy duty (Electrical/ Diesel) drivers that assembled with full discharge line control Gate & Check Valves along with flexible joints. Pressure Switches & Gauge fitted on well Supported Header, where all pre-piped, wired, & fabricated in Common Compact Skid is Fully Automatic Operated through latest Design Control Panel.

"Excel Series" Innovated design has different Combinations & Models that suite different clients requirements, as well as Hazard application needs.

The Standard Models of "Excel Series" are as Follows;

Excel Fire Pump - E.D.J. Model

Consist of Main End Suction Pump driven by Electrical Motor, Stand by End Suction Diesel Pump driven by Diesel Engine, & Vertical Jockey (maintenance) Pump that all are assembled with discharge line accessories, as well as connected with Skid Mounted Control Panel.

Available Flow Capacities -

(50, 120, 150, 250, 300, 350, 500, 750 & 1000) GPM.



Excel -E.D.J



Excel -D.J

Excel Fire Pump - D.J. Model

Consist of Main End Suction Diesel Pump driven by Diesel Engine, & Vertical Jockey (maintenance) Pump that all are assembled with discharge line accessories, as well as connected with Skid Mounted Control Panel.

Available Flow Capacities -

(50, 120, 150, 250, 300, 350, 500, 750 & 1000) GPM.

PACKAGE ASSEMBLY MODELS

Excel Fire Pump - E.J. Model

Consist of Main End Suction Pump driven by Electrical Motor, & Vertical Jockey (maintenance) Pump that all are assembled with discharge line accessories, as well as connected with Skid Mounted Control Panel.

Available Flow Capacities -

(50, 120, 150, 250, 300, 350, 500, 750 & 1000) GPM.



Excel -E.J

Horizontal Split Case Model

Consist of End Suction/Split Case Pump driven by Electrical Motor, (or /and) Split Case Diesel Pump driven by Diesel Engine, (or /and) Vertical Jockey (maintenance) Pump, all are assembled on I-Beam base separately ,where discharge line Accessories & Control Panel are supplied loosely .

Available in all Excel Series pumping flows (as per client request).

But this model is most in the following Conditions;

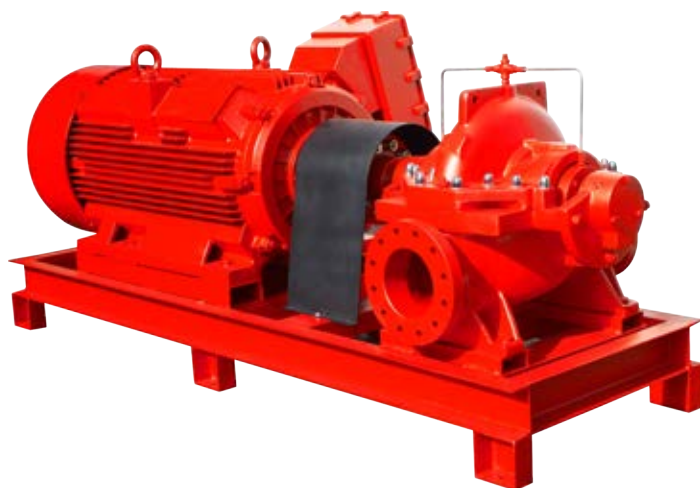

- Split Case Pump Bare Shaft.
- Flow Capacity above 750 GPM (e.g. 1000, 1250, 1500) GPM.
- High Pumping Head above 9 Bar

Note:

Optional Provision are also available in Excel Series can be Ordered up on Request such as;
- Different Combinations Double Electric (E.E.), or Double Diesel (D.D.) as Main & Stand by.
- Pressure Tank as additional on the skid or substitute to the Jockey Pump.

PUMP SKID SPECIFICATIONS

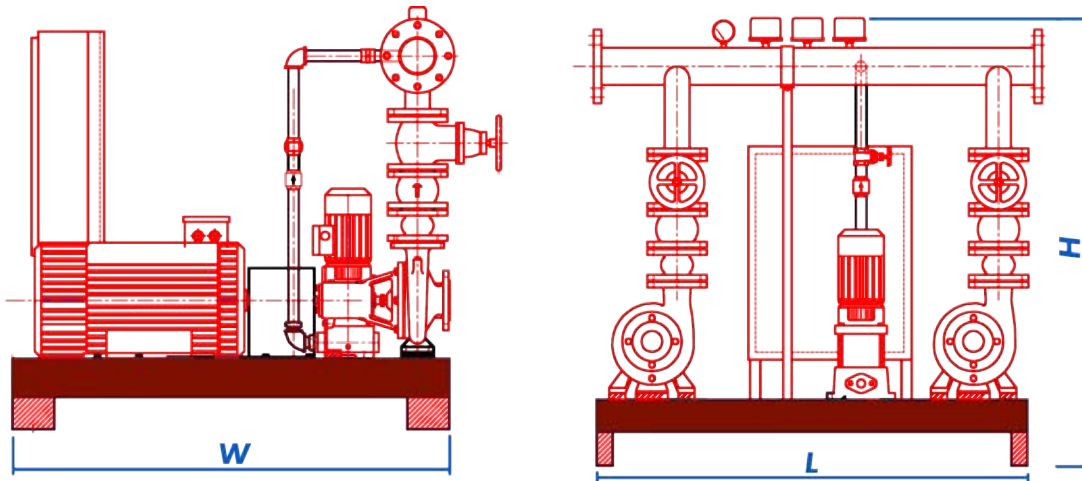

EXCEL Skid Model - E.D.J

TYPE	(GPM)	W (MM)	H (MM)	L (MM)	DIESEL (HP)	MOTOR (HP)	JOCKEY (HP/GPM)	(KG)	HEADER PIPE
EDJ	1000	1700	2220	2000	110	100	5.5/50	1500	6"
EDJ	750	1700	1680	1800	85	75	5.5/35	1200	6"
EDJ	500	1600	1680	1800	60	50	5.5/25	1092	6"
EDJ	350	1550	1630	1600	40	40	3/20	950	4"
EDJ	250/300	1220	1420	1220	25	30	3/15	870	4"
EDJ	120/150	1220	1300	1220	15	15	3/10	780	2.5"
EDJ	50	650	1250	1230	8	5.5	3/10	300	2"

EXCEL Skid Model - D.J

TYPE	(GPM)	W (MM)	H (MM)	L (MM)	DIESEL (HP)	JOCKEY (HP/GPM)	(KG)	HEADER PIPE
DJ	750	1100	1760	1700	85	5.5/35	850	6"
DJ	500	1000	1670	1600	60	5.5/25	730	6"
DJ	250/300	800	1420	1220	25	3/15	540	4"
DJ	120/150	800	1280	1220	25	3/10	480	2"
DJ	50	700	1230	830	10	3/10	190	1.5"

EXCEL Skid Model - E.J

TYPE	(GPM)	W (MM)	H (MM)	L (MM)	MOTOR (HP)	JOCKEY (HP/GPM)	(KG)	HEADER PIPE
EJ	500	900	1660	1350	50	5.5/25	640	6"
EJ	250/300	800	1420	1220	30	3/15	432	4"
EJ	120/150	800	1250	1220	15	3/10	310	2"
EJ	50	700	1230	830	5.5	3/10	170	1.5"

Note: These are our standard models. Other specifications are also available as per customer request.

SKID PACKAGE COMPONENTS

Horizontal Split Case Pump

- Capacity up to 1500 GPM with Pressure up to 12 bars.
- Split case design for easy maintenance & Upkeep. Due to easy removal of Upper casing & Inner assembly without disturbing piping Including Stuffing boxes, & bearing Housing.
- American Design in compliance with (UL) & NFPA -20 Selection Requirements.
- Engine configuration.
- Available in Electrical Motor or Diesel
- Suitable for Commercial, Residential and Industrial Applications.

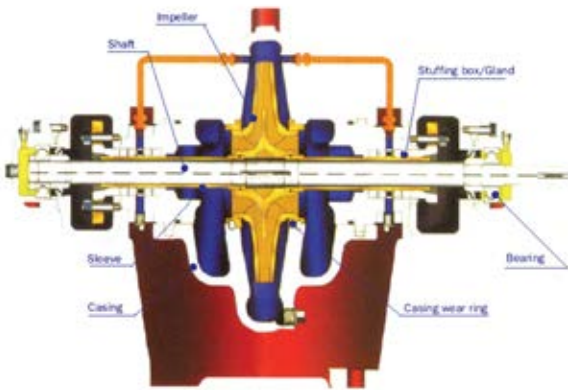
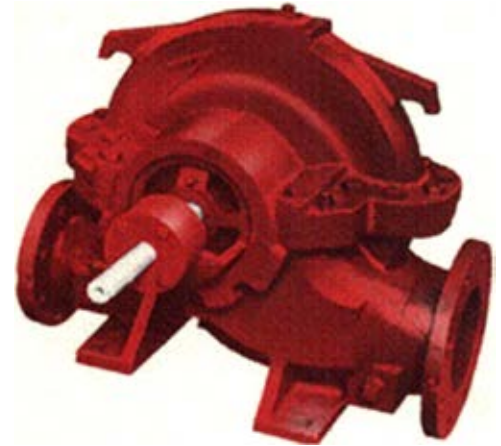

- Suction & Discharge flanges are on common Horizontal center line.
- Standard Construction of :
 - High Quality Cast iron Casing with Bronze wearing ring.
 - Bronze Impeller
 - 420 SS Shaft with 322 SS/ Bronze Sleeves.
- Grease lubrication ball bearing provide L-10 rating
- Double suction type impeller offers low Pulsation.
- Removable drip pocket with tapped drain Outlet stuffing box.

SFFECO Centrifugal Pump - Horizontal Split Case



MODEL	Inch Suction/ Discharge	Speed (RPM)	(GPM)	Head (m)	Impeller Size (mm)
SFS 125/38	6" / 5"	1760	500/750	70	380
SFS 150/38	8" / 6"	1760	1000/1250	70	375

SFFECO Centrifugal Pump - End Suction



MODEL	Inch Suction/ Discharge	Speed (RPM)	(GPM)	Head (m)	Impeller Size (mm)
SFE 80/20	4/3	2900	500	63	214
SFE 80/26	4/3	2900	500	90	264
SFE 80/32H	4/3	2900	500	145	329
SFE 100/26	5/3	2900	750	96	264

SKID PACKAGE COMPONENTS



SFFECO Centrifugal Pump - End Suction

- Capacity up to 750 GPM with pressure Up to 10 bar.
- Rear pull out design supplied as standard with spacer coupling that allow removal of rotating elements without disturbing piping Connection.
- Hydraulically balanced Impeller, assure smooth operation & long bearing life limit
- U.K. design in compliance with ANSI & NFPA - 20 Selection Requirements.
- Available in Electrical motor or Diesel Engine driven configuration.
- Suitable for Commercial, Residential & Industrial applications.
- Top centre line discharge with foot supported casing

60 Hz 3500 RPM	MODEL	Inch Suction/ Discharge	Speed (RPM)	(GPM)	Head (m)	Impeller Size (mm)
	SFF 40/20	2.5" / 1.5"	3500	150	82	214
	SFF 50/20	2.5" / 2"	3500	300	75	214
	SFF 50/20A	2.5" / 2"	3500	350	75	214
	SFF 65/20	3" / 2.5"	3500	500	82	214
	SFF 65/26A	3" / 2.5"	3500	750	120	264
	SFF 65/26H	3" / 2.5"	3500	500	128	264
	SFF 80/20	4" / 3"	3500	750	70	214
	SFF 80/26	4" / 3"	3500	750	130	264
	SFF 80/26H	4" / 3"	3500	1000	115	264
	SFF 80/32H	4" / 3"	3500	1250	155	264
	SFF 100/26H	5" / 4"	3500	1000	135	264

50 Hz 2900 RPM are available as per customer requirement

50 Hz 2900 RPM	MODEL	Inch Suction/ Discharge	Speed (RPM)	(GPM)	Head (m)	Impeller Size (mm)
	SFF 40/26	2.5" / 1.5"	2900	150	90	264
	SFF 50/26	2.5" / 2"	2900	300	87	264
	SFF 50/26A	2.5" / 2"	2900	350	80	264
	SFF 50/32H	2.5" / 2"	2900	350	130	329
	SFF 65/26	3" / 2.5"	2900	500	87	264
	SFF 65/32H	3" / 2.5"	2900	500	135	329
	SFF 80/32H	4" / 3"	2900	750	134	329
	SFF 100/32H	5" / 4"	2900	1000	138	329
	SFF 100/32HT	5" / 4"	2900	1250	140	339
	SFF 125/32H	6" / 5"	2900	1500	132	329

SKID PACKAGE COMPONENTS

Vertical In-line Pump

Vertical In-line pump is designed such that motor may be removed without complete disassemble of the pump. The back pull out design is convenient when there is a need for inspection, repair or for changing the impeller without disturbing the piping system. The vertical in-line has a centre line suction and discharge with a space saving design. The enclosed impeller may be dynamically balanced and the renewable wearing maintains peak efficiency. Each impeller has back pull out vanes to provide a clear passage way against material build up behind the impeller. The impeller is designed to reduce end thrust. Larger pumps have an additional wearing in the rear to provide additional wear resistance.



Centrifugal Vertical In-line

Item No.	Rated Head (PSI)	Rated Head (Bar)	Rated Speed (GPM)	Rated Capacity (GPM)	Refer Bulletin	Suc/ Dis.Dia	Maximum Working Pressure	Type
1	62~88	4.27~6.07	2900	200	KTG65/20II	2.5"	230 psi	2½x2½-8
2	45~54	3.1~3.72	1450	400	KTG125/32	5"	230 psi	5x5-13
3	51~83	3.52~5.7	1450	750	KTG150/40	6"	230 psi	6x6-16
4	48~80	3.31~5.52	1760	500	KTG125/32	5"	230 psi	5x5-13
5	80~120	5.52~8.27	1760	1000	KTG150/40	6"	230 psi	6x6-16



Electric Motor

HITEC motor plays a vital role in "Excel Series" Fire Pump Packages as it is Electrical Motor fire pump driver on both Main (or/and) Standby Operation, that arranged to allow power take-off through a flexible coupling directly from motor shaft "rotating element", where this power is designed to allow the working space required for serving a fire pump when a pump is directly connected to a Motor.

HITEC Induction motors are U.K. designed motors, which have been designed according to the EIC standards, with special features & characteristics have made HITEC Motors Durable Motors & Components,

Low Vibration design "Silent Functioning", Corrosion proof construction, & trouble free performance that easily to maintain. HITEC motors can handle load, & continue working reliably for long hours, also the precision balanced design ensures super performance with minimum energy consumption.

HITEC standard construction of the Motor Frame, & Shield Ends (Drive/Non-Drive) from Cast Iron, Cathode Copper Stator, & Aluminum Rotor, where both are insulated by low-carbon magnetic steel laminations. The Motor Shaft made of superior grade Steel, along with Ball Bearing fully sealed, & pre-packed with grease. Motor has IP55 Protection, and Fan Cooling with Steel Cover protection of IP 2 x, Moreover Class F insulation allows temperature rises up to 100K, & max. Temp. Of 155 °C at the machine spots.

	Model	At 60 Hz KW	HP	Speed (R.P.M)	Current A	Efficiency %	Factor Cos	Torque Nm	Noise LwdB(A)	Weight Kg.
MAINS SUPPLY 220-240,380-460V. 60 Hz, 3 PHASE, 2 POLE	HM 801 - 2	0.75	1	3400	1.8	75.0	0.83	2.54	67	16.5
	HM 802 - 2	1.1	1.5	3400	2.6	77.0	0.84	3.72	67	17.5
	HM 90S - 2	1.5	2	3420	3.4	79.0	0.84	5.04	72	21
	HM 90L - 2	2.2	3	3450	4.9	81.0	0.85	7.40	72	25
	HM 100L - 2	3	4	3450	6.3	83.0	0.87	9.95	76	33
	HM 112M - 2	4	5.5	3455	8.1	85.0	0.88	13.22	77	41
	HM 132S1 - 2	5.5	7.5	3490	11.0	86.0	0.88	18.11	80	63
	HM 132S2 - 2	7.5	10	3550	14.9	87.0	0.87	24.70	80	70
	HM 160M1 - 2	11	15	3485	21.3	88.0	0.89	35.85	86	110
	HM 160M2 - 2	15	20	3550	28.8	89.0	0.89	48.89	86	120
	HM 160L - 2	18.5	25	3490	34.7	90.0	0.90	60.30	86	135
	HM 180M - 2	22	30	3545	41.0	90.5	0.90	71.46	89	165
	HM 200L1 - 2	30	40	3545	55.5	91.2	0.90	97.12	92	218
	HM 200L2 - 2	37	50	3550	67.9	92.0	0.90	119.78	92	230
	HM 225M - 2	45	60	3560	82.3	92.3	0.90	144.70	92	280
	HM 250M - 2	55	75	3555	100.4	92.5	0.90	176.85	93	365
	HM 280S - 2	75	100	3560	134.4	93.2	0.91	241.16	94	495
	HM 280M - 2	90	125	3575	160.2	93.8	0.91	289.39	94	565
	HM 315S - 2	110	150	3575	195.4	94.0	0.91	352.51	96	890
	HM 315M - 2	132	180	3575	233.2	94.5	0.91	423.02	96	980
HM 315L1 - 2	160	220	3575	279.3	94.6	0.92	512.75	99	1055	
HM 315L2 - 2	200	270	3575	348.4	94.8	0.92	640.94	99	1110	
MAINS SUPPLY 220-380, 380-660V. 60 Hz, 3 PHASE, 2 POLE	HM 802 - 4	0.75	1	1730	2.0	73.0	0.77	5.15	58	16
	HM 90S - 4	1.1	1.5	1710	2.9	75.0	0.77	7.50	61	23
	HM 90L - 4	1.5	2	1715	3.7	78.0	0.79	10.23	61	25
	HM 100L1 - 4	2.2	3	1710	5.2	80.0	0.81	14.80	64	33
	HM 100L2 - 4	3	4	1730	6.8	82.0	0.82	20.18	64	35
	HM 112M - 4	4	5.5	1730	8.8	84.0	0.82	26.53	65	41
	HM 132S - 4	5.5	7.5	1730	11.8	85.0	0.83	36.48	71	65
	HM 132M - 4	7.5	10	1760	15.6	87.0	0.84	49.74	71	76
	HM 160M - 4	11	15	1755	22.3	88.0	0.85	71.59	75	118
	HM 160L - 4	15	20	1760	30.1	89.0	0.85	98.12	75	132
	HM 180M - 4	18.5	25	1760	36.5	90.5	0.85	120.19	76	164
	HM 180L - 4	22	30	1765	43.2	91.0	0.85	142.93	76	182
	HM 200L - 4	30	40	1770	57.6	92.0	0.86	160.96	79	245
	HM 225S - 4	37	50	1775	69.9	92.5	0.87	198.51	81	258
	HM 225M - 4	45	60	1775	84.7	92.8	0.87	290.37	81	290
	HM 250M - 4	55	75	1775	103.3	93.0	0.87	354.09	83	388
	HM 250S - 4	75	100	1780	139.6	93.8	0.87	483.95	88	510
	HM 280S - 4	90	125	1780	166.9	94.2	0.87	578.79	86	606
	HM 315S - 4	110	150	1785	201.0	94.5	0.88	707.41	93	910
	HM 315M - 4	132	175	1780	240.4	94.8	0.88	848.89	93	1000
HM 315L1 - 4	160	220	1780	287.8	94.9	0.89	1028.96	97	1055	
HM 315L2 - 4	200	270	1785	359.4	95.0	0.89	1286.20	97	1128	

SKID PACKAGE COMPONENTS

Diesel Engine

Mega-Force engine plays a vital role in "Excel Series" Fire Pump Packages as it is Diesel engine fire pump driver on both Main (or/and) Standby Operation, that arranged to allow power take-off through a flexible coupling directly from engines rotating element, where this power is designed to allow the working space required for serving a fire pump when a pump is directly connected to an engine.

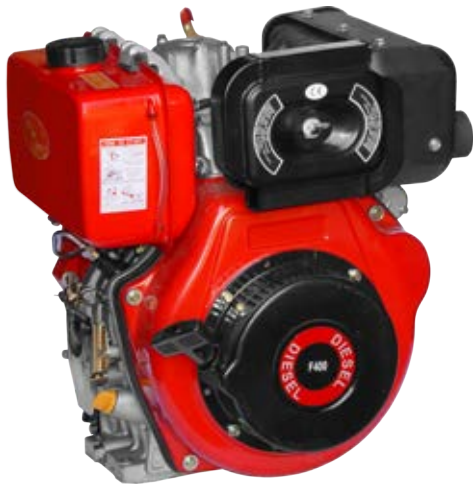
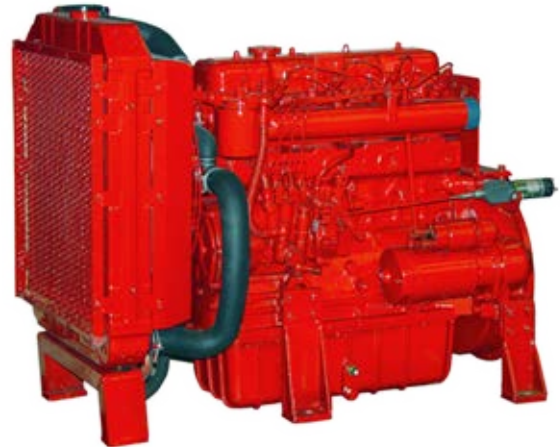

Mega-Force is U.K designed engine that has been engineered to have Longer Life Limit, Strong Reputation & Reliability, Heavy Duty, Easy to Maintain & Optimum Performance, thus guaranteeing the product best suited to the application, also calibrated to specific Power & Speed requirements to ensure Maximum Efficiency. **Mega-Force** standard construction of Engine Block, Cylinder Head Assembly made of Alloy Casting Iron, where the Crankshaft & Flywheel Assembly is made of strength modular cast iron or alloy steel equipped with balance weight. Bearing of steel & high tin Aluminum alloy, Forged Steel Connecting Rods, & Steel No. 45 camshaft. Equipped with Radiator Cooling, Electrical Starter, & Flexible Exhaust.

Mega-Force range offers from small cylinder engine giving an output of 19 KW at 2900 RPM to a high powered configured engine of 400 KW. All Power units are manufactured to comply with strict control procedures & fully tested against the applicable standards in line with client requirements. Such wide range has made Mega-Force suitable choice for many applications like Fire fighting, Construction, Agricultural & Industrial Sectors.

Diesel Engine - Mega-Force

Model	Type	No. of Cylinders	Bore * Stroke (inch)	Rated power/ Speed (hp/r.pm)	Net Weight (KG)	Shaft	Oil Liter Volume
M400	Air Cooling	1	1.5 * 1.7	10 HP / 2900			1.7
MFS25	Vertical Water - Cooling, 4-Stroke, direct-injection combustion chamber	3	3.15 * 3.54	25 HP / 3000	200	42 mm	3
MFS40		4	3.15 * 3.54	40 HP / 2900	260	48 mm	7
MFS60		4	3.78 * 4.13	60 HP / 3000	300	48 mm	7
MFS75		4	3.85 * 4.13	75 HP / 3000	310	60 mm	7
MFS85		4	4.02 * 4.65	85 HP / 3000	350	60 mm	7
MFS110		4	4.22 * 4.90	110 HP / 2900	400	60 mm	9
MFS150		6	4.02 * 4.65	150 HP / 3000	500	65 mm	13
MFS170		6	4.33 * 4.92	170 HP / 2900	650	65 mm	15

YOUR RIGHT CHOICE PROTECTION OF LIFE

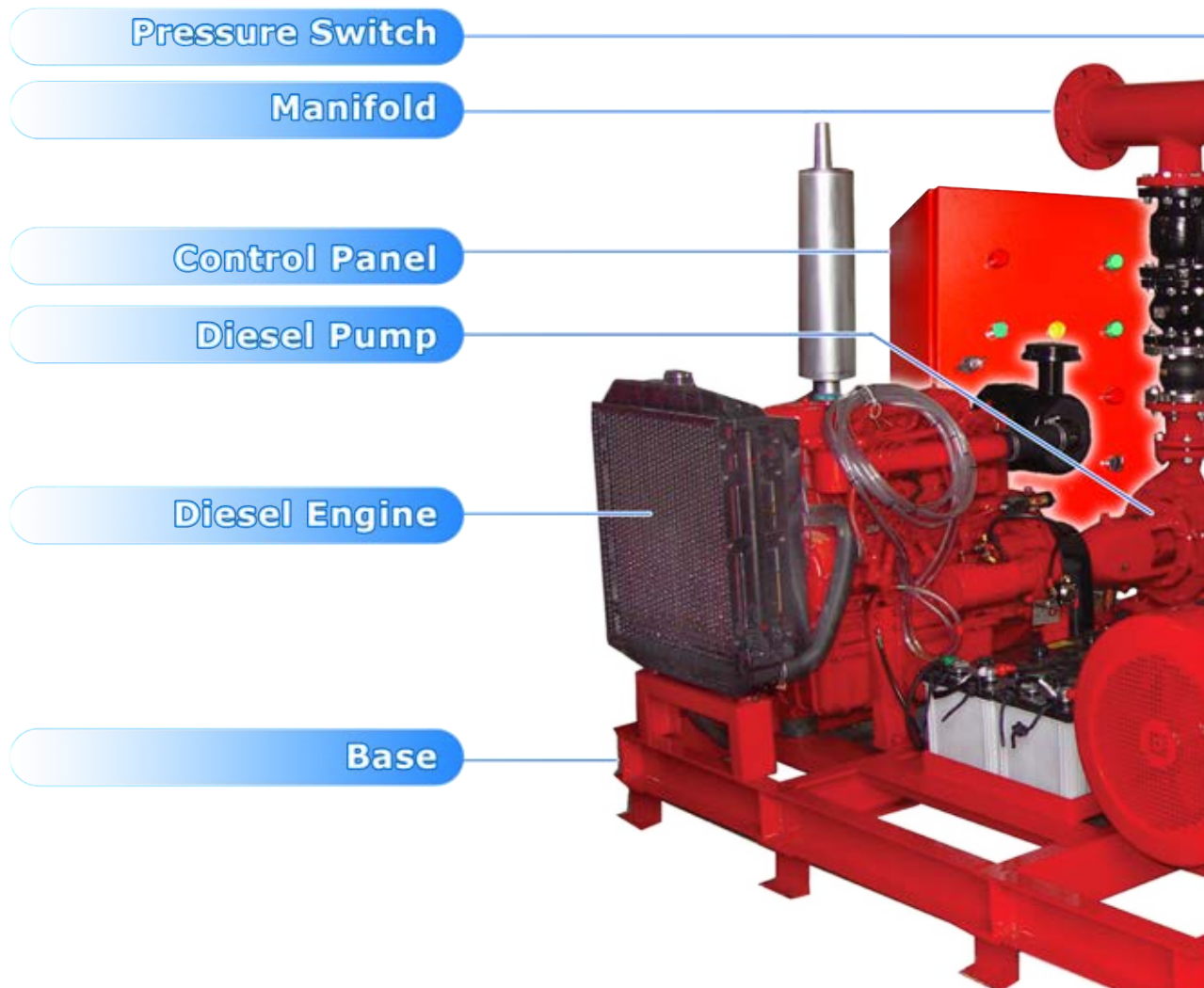

Features &

◇ Space Saving Design Efficiency:

Nothing beat **Excel Series** packages since allows to fit in to small spaces.

◇ Easy to Install & Handle:

Excel Series I beam base provide easy lifting slots.

◇ Available in capacities from 50 GPM up to 1500 GPM and pressure range up to 12 BAR.

◇ Pre-fabricated, pre-piped wired, factory tested unit.

SELECT WITH

AGE DETAILS

CHOICE FOR THE LIFE AND PROPERTY

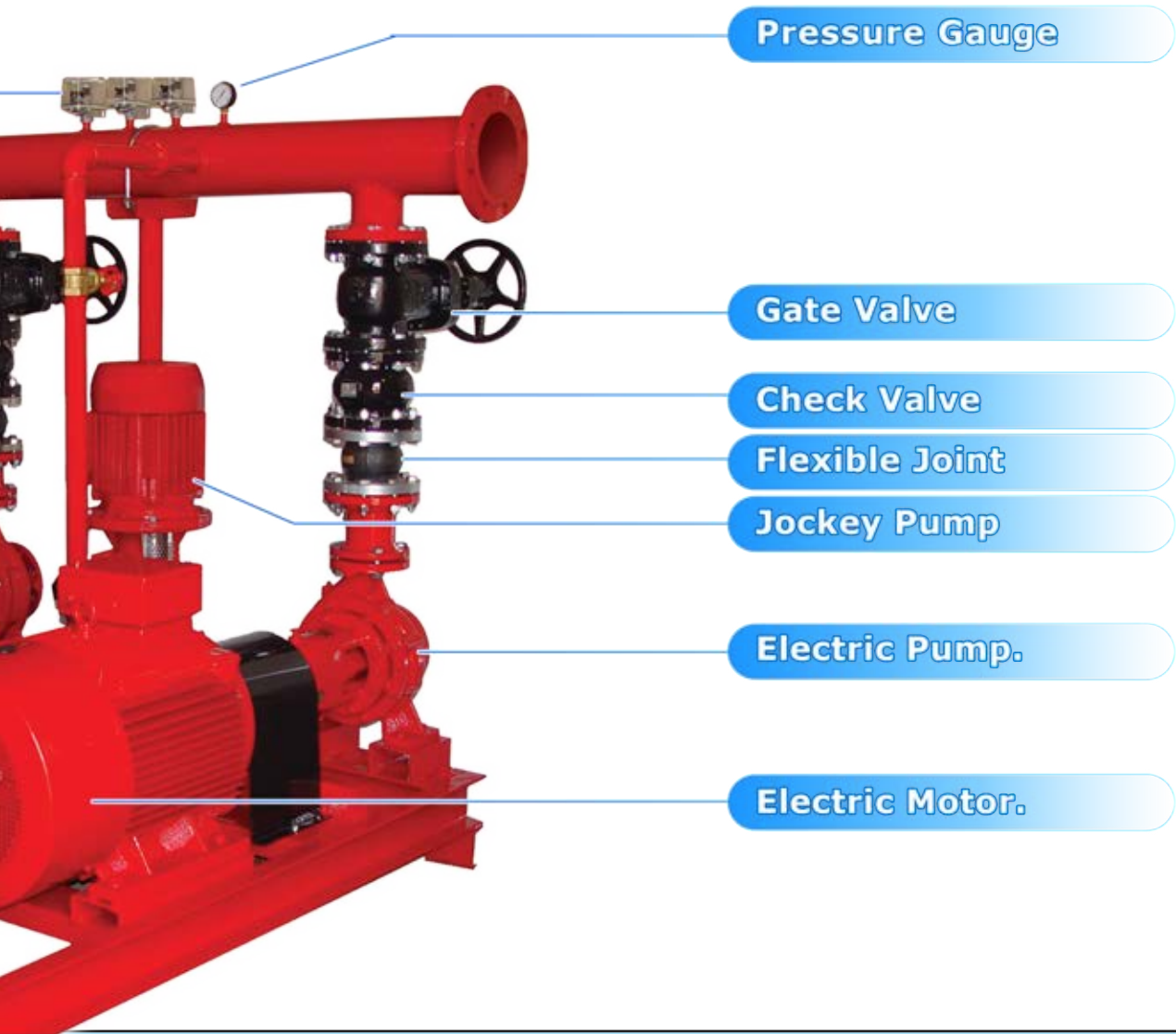

& Benefits

- ◇ In compliances with local civil defense requirement & NFPA 20 selection & operation procedure.
- ◇ Pumps coupled with heavy duty trouble free electrical & diesel drivers.
- ◇ Dynamic balanced pumps impellers.
- ◇ Pump set piping is hydrostatically tested to ensure piping integrity.

CONFIDENCE

Vertical Multistage stainless steel ce

Application:

The **GMAX** series is a multipurpose pump range suitable for a variety of different applications demanding reliable and cost efficient supply.

- Thin, non-explosive liquids, not containing solid particles. Handles various liquids from portable water to industrial liquids within a very wide temperature, flow and pressure scales.
- When pumping liquids with a higher density (or) viscosity, the correction for the same has to be done for capacity, head and power factors.

Usage:

- Pressure boosting in high-rise buildings, hotels, etc.
- Municipal water supply and pressure boosting
- Boiler feed and condensate systems
- Washing plants and wash down irrigation and dewatering
- Domestic water supply
- Cooling water systems
- Fire fighting

Example:

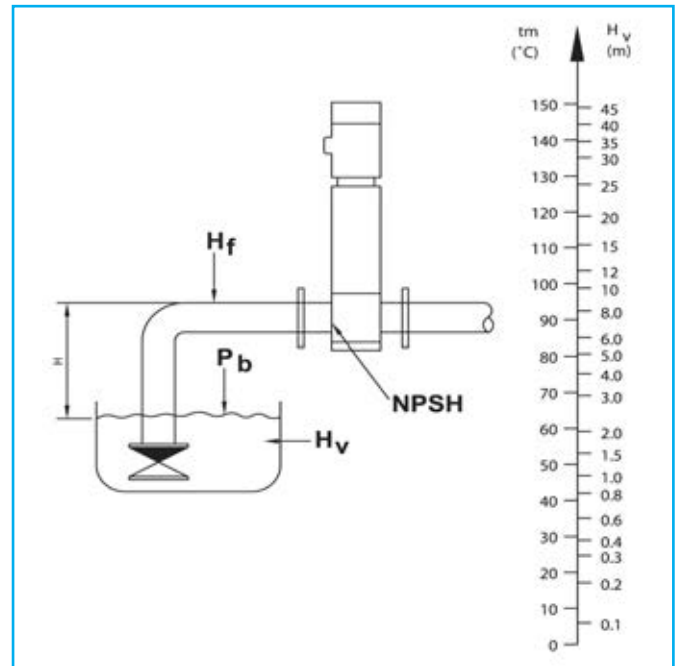
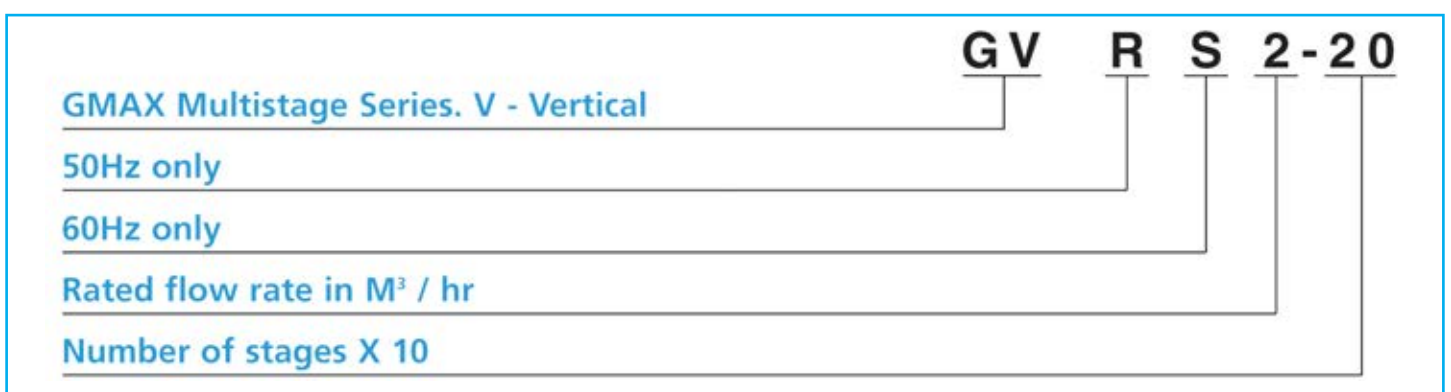

Check the pump is not and will not be exposed to cavitation

a. Liquid Temperature:

Normal Operating - Ambient

Liquid - Std Design - -15°C to +90°C

Hot Water - -15°C to +120°C

b. Minimum inlet pressure - NPSH

- Calculation of the inlet pressure "H" is recommended when...
- The liquid temperature is high
- The flow is significantly higher than the rated flow
- Water is drawn from depths
- Water is drawn through long pipes
- Inlet conditions are poor

Two-stage in-line centrifugal pumps

To avoid cavitation, make sure that there is a minimum pressure on the suction side of the pump. The maximum suction lift "H" in meters head can be calculated as follows

$$H = P_b \times 10.2 - NPSH - H_f - H_v - H_s$$

P_b = Barometric Pressure in bar.

(Barometric pressure can be set to 1 bar.)

In closed systems, P_b indicates the system pressure in bar.

NPSH = Net Positive Suction Head in meters head.

(To be read from the NPSH curve at the highest flow the pump will be delivering.)

H_f = Friction loss in suction pipe in meters head.

(At the highest flow the pump will be delivering.)

H_v = Vapor pressure in meters head.

(To be read from the vapor pressure scale. " H_v " depends on the liquid temperature " T_m ")

H_s = Safety margin = minimum 0.5 meters head.

(To be read from the vapor pressure scale.

" H_v " depends on the liquid temperature " T_m ")

If the "H" calculated is positive, the pump can operate at a suction lift of maximum "H" meters head.

If the "H" calculated is negative, an inlet pressure of minimum "H" meters head is required.

Electrical Data

Protection Class: IP55

Insulation Class : F

Standard Voltage: 50Hz.: 3 x 200-220 / 346-380V
3 x 220-240 / 380-415V
3 x 380-415V

Standard Voltage: 60Hz.: 3 x 200-230 / 346-400V
3 x 200-255 / 380-440V
3 x 200-277V/380-480V

c. Motor

The motor is Totally Enclosed, Fan-Cooled, 2-pole with principal dimensions in accordance with EN standards

Electrical tolerances according to EN60034

Motor Protection

- Single phase motors have a built in thermal overload switch
- Three phase motors must be connected to a motor starter in accordance with local regulations
- Three phase motors from 3kW and upwards have a built-in thermostat (PTC) according to DIN 44 082.

Ambient Temperature

Maximum +40°C

If the ambient temperature exceeds +40°C or if the motor is located 1000 meters above sea level, the motor output (P2) must be reduced due to the low density and consequently low cooling effect of the air. In such cases, it may be necessary to use a motor with a higher output.

Vertical Multi stainless steel ce



	Model	Inch Suction/ Discharge	Speed (RPM)	(GPM)	Head(m)
Jockey Pump	GVS 4-60	1 ¼	3500	20	70
	GVS 8-60	1 ½	3500	50	70
	GVS 8-120	2"	3500	50	120
	GVS 16-80	2"	3500	100	120

Two-stage in-line centrifugal pumps



Material: GVR/GVS

Pump head	Cast iron EN-GJL-200
Pump head cover	Stainless steel 304
Shaft	Stainless steel 304 (or) 316
Base	Stainless steel 304 (or) 316
shaft seal	Mechanical
Base plate	Cast Iron EN-GJL-200
Rubber parts	EDPM or FKM
Impeller	Stainless steel 304 (or) 316
Chamber	Stainless steel 304 (or) 316
Outer sleeve	Stainless steel 304 (or) 316
O-ring for outer sleeve	EDPM or FKM

* Stainless steel on request
 Pump components can be supplied in ss 304 or ss 316

FIRE PUMP CONTROLLERS

"**Excel Series**" Fire Pump Unit Controller is the Pump Package brain that designed to Control & Monitor the operation of the Main, Standby, and Jockey pumps Drivers, and makes up pumps for both Manual & Automatic modes, as well as turns pumps drivers ON/OFF under specific conditions.

The Fire Pump Package Controller detects signals through set of built in switches that reflect the system Pressure & Flow status enabling fire pump package drivers (Electrical /Diesel /Jockey) to operate in case of pressure in the system is lower than set point, as well as operating the Stand by driver due to power failure and/or substantial drop in pressure.

SFFECO's **Excel Series** Controllers are pre-wired, and factory tested before shipment and made ready for immediate usage.

Pump Controller Features

- Standard Dry Run Protection (above 100 GPM pumps).
- DOL - (Below 60 HP Motor Size) / Star Delta Starter Circuit available up on request.
- Different Mounting Styles.
- NFPA Arrangement / IP standard Available up on request (Optional).
- Low Maintenance Cost and available spare parts.
- Standard cable marking for easy maintenance.
- Low Pressure cut-off (timer based) (optional).
- Automatic or manual (test) operation.
- Compatible with any remote signaling or monitoring systems like BMS OR FACP.
- Electronic battery charger (current sensing).
- Lamp test facility (optional).
- Fault Trip facility (other than dry run - optional).
- Crank protection circuit for diesel engine (optional).
- Delayed start for fire signal (optional).
- Strong, Reliable and Elegant Standard Red Powder Coated Galvanized Steel Enclosure.
- Stainless Steel Enclosures are available for out door applications (Optional).

Model A

- Wall & Base mounted arrangement.
- Standard up to 250 GPM Skid size.
- Standard as common panel for Electrical, Diesel & Jockey drivers.
- Seperate arrangement is available up on request.

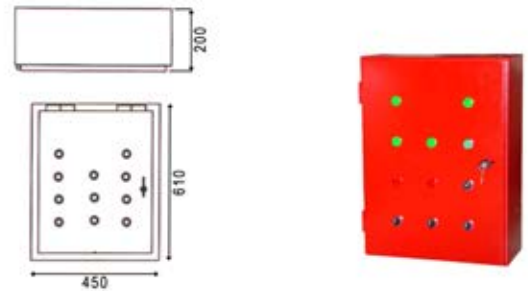

Model B

- Wall & Base mounted arrangement.
- Standard up to 750 GPM Skid size.
- Standard as common panel for Electrical, Diesel & Jockey drivers.
- Seperate arrangement is available up on request.

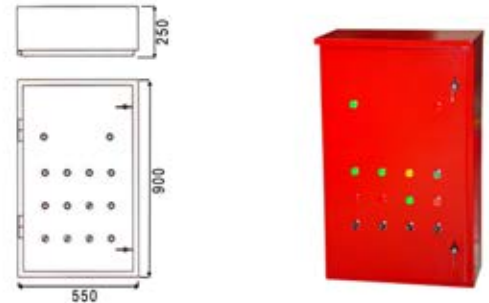

Model C

- Standard self standing arrangement.
- Standard up to 1500 GPM (Star Delta) Skid size.
- Standard as common panel for Electrical, Diesel & Jockey drivers.
- Seperate arrangement is available up on request.

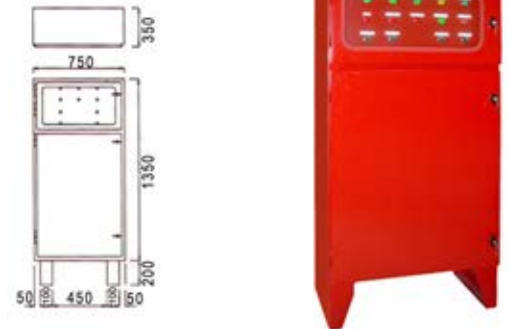

Model D [Optional]

- Standard self standing arrangement.
- Standard as common panel for Electrical, Diesel & Jockey drivers.
- Seperate arrangement is not available.

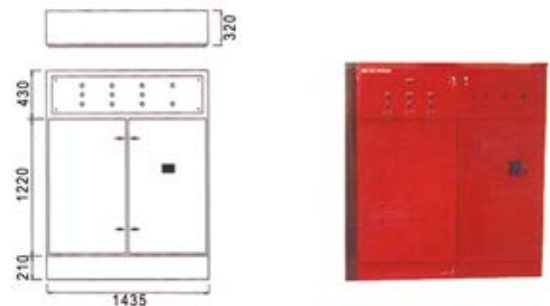

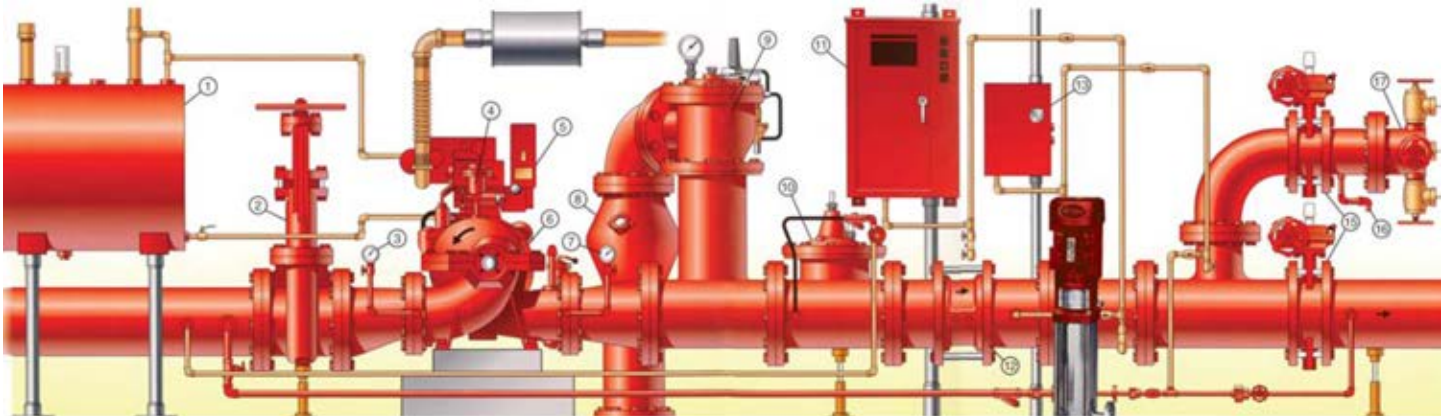

- | | | |
|------------------------------------|---|--|
| 1. Fuel Tank Diesel Engine | 7. Discharge Pressure Gauge | 13. Jockey Pump Controller |
| 2. Isolation Gate Valve (suction) | 8. Enclosed Waste Cone with Sight Glasses | 14. Jockey Pump |
| 3. Compound Suction Gauge | 9. Main Relief Value | 15. Isolation Values |
| 4. Automatic Air Release Value | 10. Low Suction Pressure Shutoff Value | 16. Ball Drip Value |
| 5. Diesel Engine Drive | 11. Fire Pump Controller | 17. Test Value Manifold with Hose Values,
Caps & Chains |
| 6. Horizontal Split Case Fire Pump | 12. System Check Value | |

Gate Valve



Listed gate or butterfly valves are to be used when required in the system or as shown in the above typical system. Butterfly valves are for use only in the discharge assembly. Valve opening is same as the inside dia of pipe. So that there is little pressure drop through a gate valve. This valve is used for throttling the flow.

Hose valves are UL/FM approved and are furnished in the required quantity for a given fire pump size by NFPA 20. The threads will generally be NPT standard with caps and chain

Hose Valve



Ball Drip Valve



When the hose header is located outside, or at distance from the pump, and danger of freezing exists, a ball valve or indicating drain valve shall be located in the pipeline to the hose header. The valves will allow the water to be drained when not in use. Thus prevents the line from breakage, in winter due to freezing.

Gauges



A Suction and discharge gauge is furnished for each fire pump. With a minimum dial size of 3 ½ inch, the pressure range shall be twice the working pressure of the pump with a minimum of 200 psi. Our standard gauges read in psi, have a range of 300 psi and are compound pressure and vacuum type.

Pumps which are connected to diesel engine or steam turbine drives, shall be equipped with a listed main relief valve. The main relief valve size shall be greater than or equal to the values given in NFPA 20. The valves are set to prevent a pressure on the fire protection system greater than it can withstand. Spring loaded and pilot operated types are available in UL-FM Design. The main relief valves are also used when the shut off pressure plus the static suction pressure exceeds the rated system pressure.

Main Relief Valve



Casing Relief Valve



The casing relief valve provides a vital function on electric driven units. When set properly, the valve permits enough water to discharge to a drain to prevent the pump from overheating when running at conditions near shutoff. The valve will have an adjustable range which is set in the field. Engine driven units do not require a casing relief valve for which water is continuously drawn through the pump for engine heat exchanger cooling purpose.

Flexible Exhaust Connectors

A flexible connector is provided at the exhaust out let of the engine. The connector relieves thermal expansion strains and helps dampen transmitted engine vibration.



Exhaust Silencer



An industrial exhaust silencer providing 10 - 15 DBA reduction is furnished with each diesel unit; other grades are available to suit individual job requirements

In place of, or, in addition to the hose valve header with hose valves, we offer a complete line of UL/FM approved flow meter which can adequately test the fire pump performance in cases of liquid water supply. Available in calibrated venture design with a wall or pipe mounted dial meter reading in GPM. The system provides a +/- 1% accuracy, when installed properly. The venture principle provides a clog-free design and allows the most compact piping arrangement of any other flow meter design.

Flow Meter System





Eccentric Suction Reducer



The suction piping is sized such that the NPSH available will be greater than 19 ft. absolute, when operating at 150% of the rated capacity, but not less than the minimum values given by NFPA 20. The piping size may be different than the pump suction size necessitating the need for an eccentric reducer. An eccentric fitting is used to prevent the possibility of air pockets forming in the line as would be experienced if a concentric fitting were used.

Concentric Discharge Increaser

The discharge pipe size shall not be less than the values given by NFPA20. These values are generally different than the pump discharge size and hence the need for an increasing or reducing or reducing fitting. Since our fire pumps have been designed specifically for fire pumps usage, the suction and discharge connections will match the NFPA 20 minimum values. In most cases, when there is a need for reducer or increaser a fitting is eliminated, saving cost and installation time.



Automatic Air Release Valve



The automatic air release valve releases air that may accumulate in the volute of the horizontal split case pumps. The valve is not required in self venting end suction pump. The minimum size is a 1/2 inch inlet and the valve is installed at the top of the pump volute.

Enclosed Waste Cone

The enclosed or open waste cone is connected directly to the main relief valve and provides a visual indication of the water discharging through the line. The fitting also increases the line size from the relief valve as required by NFPA 20. The enclosed cone is provided with a sight glass.



90 deg Elbow



Standard 90° elbows are required in the piping arrangement as shown for the main relief valve drain, hose header line, and as needed for any given layout. Which reduces pressure loss in the line by avoiding turbulence in the flow.

A listed check valve is furnished in the piping arrangement as shown. They are extremely effective in preventing back pressure or back flow features a low 0.5 psi (0.03Box) cracking pressure differential and are capable of handling pressure to 275 psi (19 bar).

Check Valve



ORDERING INFORMATION

Fire Pump Specification

Flow Required _____ GPM Pressure Rating _____ Bar

Package Model EJ DJ EDJ Other _____

Pressure Tank Required Yes No

Base Arrangement Full Skid Seperate Pumps

Site Voltage _____ Volt AC Site Breaker Size _____ Amps

Current Frequency _____ Hz. Pressure Tank Capacity _____ Ltr.

Pump Controller Specification

Arrangement With Pumps Common Seperate

Panel Mounting Wall Mounted Self Standing Base Mounted

Model Standard Other _____

Connection Mode DOL Star-Delta

Note: If flow & pressure is not known; Please send brief description of application (hazard), Pump location, connection system (hydrant, Sprinkler...etc) as well as maximum height.

SAVE



www.SFFECO.com

Factory & Head Office - Riyadh

2nd Industrial Area, Al-Kharj Road, Riyadh, KSA
Wasel: 7275, Code: 14334, Addition Number: 4441
Tel : +966 11 2650070, Fax: +966 11 2652190
E-mail: riyadh@sffeco.com.sa

SFFECO GLOBAL Office

JAFZA (South), Dubai, UAE, P.O. Box 261318
Tel: +971 4 880 9890, Fax: +971 4 880 9822
E-mail: sales@sffecoglobal.com

Jeddah Branch

P.O. Box: 16769, Jeddah - 21474, KSA
Tel : +966 12 670 6009, Fax: +966 12 676 0307
E-mail: jeddah@sffeco.com.sa

Dammam Branch

P.O. Box: 7162, Dammam - 31462, KSA
Tel : +966 13 8351961, Fax: +966 13 8351968
E-mail: dammam@sffeco.com.sa

Madinah Branch

Tel : 0148660959, 0148283256
Fax: 0148660969
E-mail: madinah@sffeco.com.sa

In line with our policy of continuous product improvement; we reserve the right to modify the specifications without prior notice.



DECADES
of
EXCELLENCE