

Zone Assembly

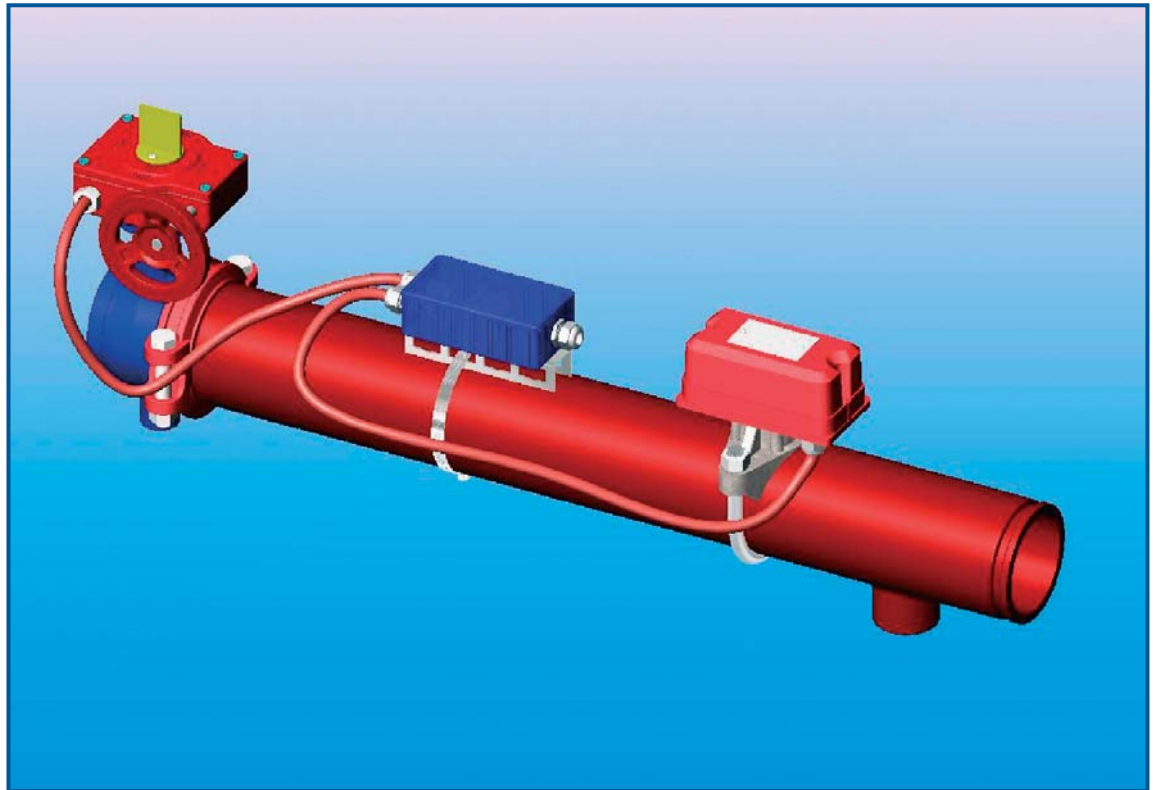

Description

The Rapidrop zone assembly is a compact unit that fulfills the requirements of BS5306 (Part 2) and BS EN 12845. It is used where sprinkler systems are divided into zones, typical applications include shop units and high rise buildings. The flow switch will detect water flow as a result of sprinkler head or test valve activation. This signal indicates in which zone the activation has taken place. A signal is also received from the isolation valve when it is fully open and when it starts to close. When required the isolation valve can be closed to isolate the system down stream of the valve.

Pressure & Rating

Max Working Pressure: 12 Bar

Component Specification

Butterfly Valve	Grooved GP300. Optional FM/UL HPG300
Flow Switch	System Sensor WFDE, FM/LPCB/VdS/CE
Electrical Cable	LPC FP200. Optional double switch wiring.
Junction Box	IP54, dual entry, single conduit outlet. Optional flying lead.
Steel Tube	BS EN 10255 Medium Grade
Finish	Red Oxide Primer. Optional gloss red epoxy powder coating.
Test and Drain	Rp 2 outlet

Optional drain and test valves.

- a) 25mm and 32mm UL Listed or 50mm two position drain and test valve, stop valve and sight glass.
- b) 50mm FM Approved three position drain and test valve with sight glass
- c) 15mm, 25mm, 32mm, 40mm or 50mm brass drain ball valve.

Rapidrop Global

Zone Assembly

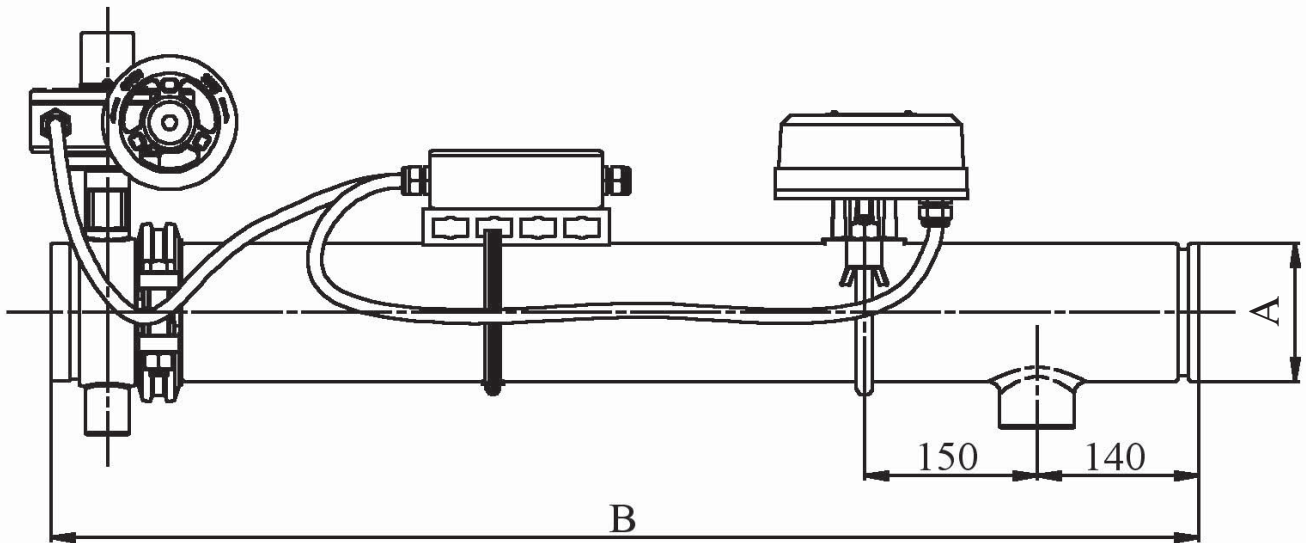

Dimensions

Size A (mm)	B (mm) including valve	Dry Weight (KG) including valve
65	996	33
80	996	38
100	1018	45
150	1045	61

Installation and Maintenance

Choose a suitable location at a height that allows access for installation, adjustment and operation. Support the assembly using approved hanging methods and attach with grooved couplings. A competent person must make all electrical connections.

Perform a weekly test to operate the flow switch and ensure that the correct status signal is received.

The Rapidrop Zone assembly is designed to be maintenance free, however in the unlikely event of component failure, replacement parts are available from Rapidrop Limited.