

Residential Flush Pendent Sprinkler Model: ZN-RES (SIN/RD201), K=4.2 PTFE Gasketed Orifice Seal Design

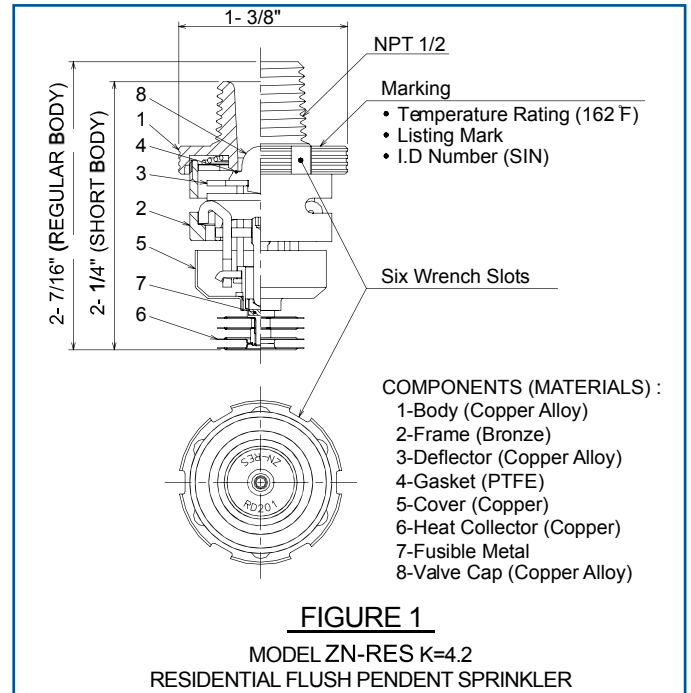
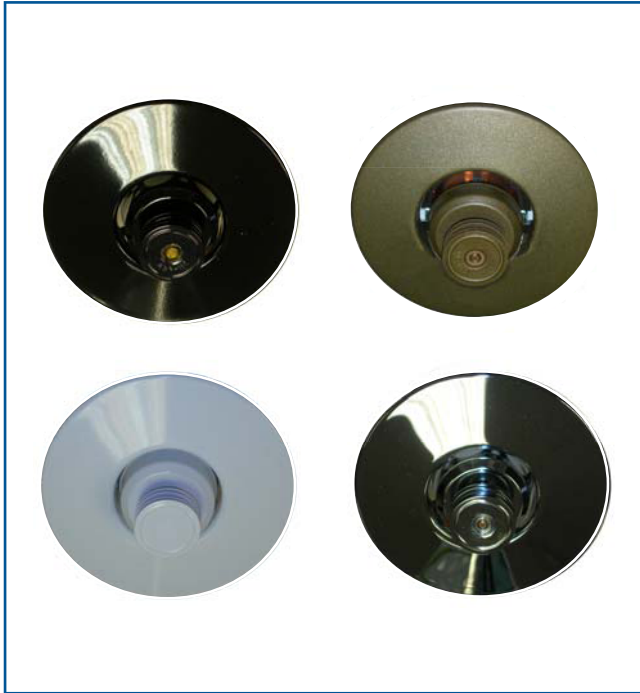

General Description

The Model ZN-RES Residential Flush Pendent Sprinklers are automatic sprinklers of the compressed fusible solder type. They are decorative, low profile, flush mount sprinklers. The Frame and Cover of the sprinkler hide the Deflector and Valve Cap assemblies. (Reference Figure 1)
The Model ZN-RES is designed for use in residential occupancies such as homes, apartments, dormitories, and hotels. When aesthetics is the major consideration, the Model ZN-RES should be your first choice.

They are to be used in wet pipe residential sprinkler systems for one- and two-family dwellings and manufactured homes per NFPA 13D; wet pipe residential sprinkler systems for residential occupancies up to and including four stories in height per NFPA 13R; or, wet pipe sprinkler systems for the residential portions of any occupancy per NFPA 13.

The Model ZN-RES has a 4.2 (60.5 LPM / bar^{1/2}) K-factor which provides very low design flow rates at reduced residual pressures, enabling smaller pipe sizes and water supply requirements.

The flush design of the Model ZN-RES features a separable escutcheon providing 3/8 inch (9.5 mm) vertical adjustment.
This adjustment reduces the accuracy to which the fixed pipe drops to the sprinklers must be cut to help assure a perfect fit installation.

The Model ZN-RES has been designed with heat sensitivity and water distribution characteristics proven to help in the control of residential fires to improve the chance for occupants to escape or be evacuated. However, residential fire sprinkler systems are not a substitute for intelligent fire safety awareness or fire safety construction required by building codes.

Technical Data

Approvals :

cULus Listed.

Sprinkler Identification Number (SIN):

RD201

Maximum Working Pressure:

175 psi (12.1 bar)

Discharge Coefficient :

K = 4.2 GPM / psi^{1/2} (60.5 LPM / bar^{1/2})

Temperature Rating :

162 °F / 72 °C

Vertical Adjustment :

3/8 inch (9.5 mm)

Finishes :

Sprinkler and Escutcheon :

White Paint, Black Paint, Dark Brown Paint, and Chrome Plate.

Physical Characteristics :

Dezincification resistant Copper Alloy body and PTFE gasketed orifice seal design.

Continued Overleaf
Page 1 of 7

Operation

The Sprinkler assembly contains a small fusible solder element. When exposed to sufficient heat from a fire, the solder melts and enables the internal components of the sprinkler to fall away. At this point the sprinkler activates with the deflector dropping into its operated position (Reference Figure 2), permitting water to flow.

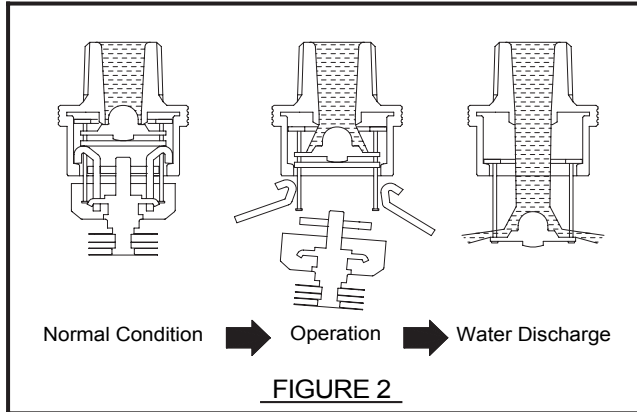

Design Criteria

The Model ZN-RES Residential Flush Pendent Sprinklers must only be installed and utilized in accordance with the following described criteria, which are provided by the manufacturer.

TABLE A		
NFPA 13D AND NFPA 13R HYDRAULIC DESIGN CRITERIA		
MAXIMUM COVERAGE AREA ^(a) (FT×FT)	Temperature Rating : 162°F(72°C)	
	Minimum Flow ^(b) Residual Pressure for Horizontal Ceiling.	
	Flow	Pressure
12×12	13GPM (49.2LPM)	9.6PSI (0.07MPa)
14×14	13GPM (49.2LPM)	9.6PSI (0.07MPa)
16×16	14GPM (53.0LPM)	11.1PSI (0.08MPa)
18×18	18GPM (68.1LPM)	18.4PSI (0.13MPa)
20×20	22GPM (83.3LPM)	27.4PSI (0.19MPa)
MAXIMUM COVERAGE AREA ^(a) (FT×FT)	Temperature Rating : 162°F(72°C)	
	Minimum Flow ^(b) Residual Pressure for Sloped Ceiling. (Max. 8 inch Rise for 12 inch Run) Maximum distance from the floor to the ceiling peak of 24 ft. A maximum of two sprinklers installed at the peak. (within 3ft vertically) Loft type or second floor openings remain outside.	
	Flow	Pressure
16×16	17GPM (64.3LPM)	16.4PSI (0.11MPa)
18×18	22GPM (83.3LPM)	27.4PSI (0.19MPa)
20×20	22GPM (83.3LPM)	27.4PSI (0.19MPa)

(a) For coverage area dimensions less than or between those indicated, it is necessary to use the minimum required flow for the next highest coverage area for which hydraulic design criteria are stated.
(b) Requirement is based on minimum flow in GPM from each sprinkler. The associated residual pressures are calculated using the nominal K-factor. Refer to Hydraulic Design Criteria Section for details.

NOTES

Residential Fire Sprinkler Systems should only be designed and installed by those component and completely familiar with automatic sprinkler system design, installation procedures, and techniques.

Several criteria may apply to the installation and usage of each sprinkler. Consequently, it is recommended that the sprinkler system designer review and develop a working understanding of the complete list of criteria prior to initiating the design of the sprinkler system.

Questions concerning sprinkler installation and usage criteria, which are not coverage by the following instructions, should be submitted to Rapidrop Ltd. Include sketches and technical details as appropriate.

In some instances, the requirements of this document may concern specifications which are more stringent and which take precedence over those specified in NFPA 13, NFPA 13D, NFPA 13R, or by the authority having jurisdiction.

The spray from the sprinkler is distributed radially outward and downward from the sprinkler deflector. Consequently, the sprinklers must be located such that there will not be any blind spaces shielded from spray by partitions, room dividers, overhangs or other parts of the dwelling structure.

The number of sprinklers within each compartment (as defined by NFPA 13, 13D, or 13R) must be kept as few as possible. Do NOT use more sprinklers than necessary to cover a particular space.

Use only the escutcheon provided with the Model ZN-RES. The sprinkler must be secured in position by firmly fastening the sprinkler system piping to the structure. If the sprinkler is not properly secured in position, reaction forces resulting from sprinkler operation could alter its orientation and its water distribution pattern.

The sprinkler escutcheon cannot be used to hold the sprinkler in position.

Obstruction to Water Distribution

Locations of sprinklers are to be in accordance with the obstruction rules of NFPA 13 for Residential Sprinklers.

Precautionary Warnings for Corrosive Environments

Model ZN-RES should not be installed where they may be subjected to a corrosive environment including the following:

1) Chlorine ion and Chloride environment.

Stress corrosion cracking may be caused by exposure to environments with Chlorine ion and Chloride. Exposure to this environment may result in sprinklers operating under non-fire conditions or not operating when exposed to an actual fire.

2) Sprinkler system piping with Copper.

Sprinkler systems should be constructed in compliance with the applicable standards and the requirements for the copper piping when copper piping is used in the sprinkler system. (Reference standards NFPA 13, ASTM B813, ASTM B828, and CDA (Copper Development Association) – Solder Joint)

All residual flux must be removed from the interior and exterior of copper piping by thoroughly flushing before installation of the Sprinkler Heads. Otherwise, residues of flux may cause corrosion and leakage in the sprinkler system.

General Service Conditions

The Model ZN-RES must only be utilized in wet pipe sprinkler systems.

Hydraulic Design Criteria

The minimum required sprinkler flow rates for systems designed to NFPA 13D or NFPA 13R are given in Table A as a function of temperature rating and the maximum allowable coverage areas. The sprinkler flow rate is the minimum required discharge from the most hydraulically demanding sprinkler from each of the total number of

"design sprinklers" as specified in NFPA 13D or NFPA 13R.

For systems designed to NFPA 13, the number of designed sprinklers is to be the four most hydraulically demanding sprinklers. The minimum required discharge from each of the four sprinklers is to be the greater of the followings;

- The flow rates given in Table A for NFPA 13D and 13R as a function of temperature rating and maximum allowable coverage area.
- A minimum discharge 0.1gpm/sq.ft. over the "design area" comprised of the four most hydraulically demanding sprinklers for the actual coverage areas being protected by the four sprinklers.

Operational Sensitivity Criteria

For proper operational sensitivity, the model ZN-RES must be installed beneath a solid ceiling having a smooth or textured surface.

The Model ZN-RES must **NOT** be used above or below open-gridded type suspended ceilings; beneath soffits or beams exceeding 3 inches in height unless installations are in accordance with Beam Ceiling Design Criteria described below; or, with beams, joists, or ducts having a height of more than 3 inches located within the sprinkler coverage areas.

Beams having a height of more than 3 inches may be located with their centerlines along the boundaries separating adjacent sprinkler coverage areas.

Sprinkler Spacing Criteria

The minimum spacing between sprinklers is 8 feet. The maximum spacing between sprinklers cannot exceed the length of the coverage area being hydraulically calculated.

Heat Source Criteria

Refer to NFPA 13D or NFPA 13R for the requirements relating to preventing the possible release of a Model ZN-RES heat responsive element, due to exposure to heat sources other than an actual fire.

Beam Ceiling Design Criteria

The Model ZN-RES (RD201) Residential Flush Pendent Sprinklers are UL Listed for installation in residential occupancies with horizontal ceilings (i.e., slopes up to a 2 inch rise over a 12 inch run) with beams when installed in accordance with the following criteria:

General Information.

The basic concept of this protection scheme is to locate the sprinklers on the underside of the beams, Ref. Figure 3, (not in the beam pockets); to identify the main beams that principally run in one direction as "primary beams"; and, to identify the beams that run principally perpendicular to the main beams, as may be present (or in some cases may be necessary for proper sprinkler protection), as "secondary beams".

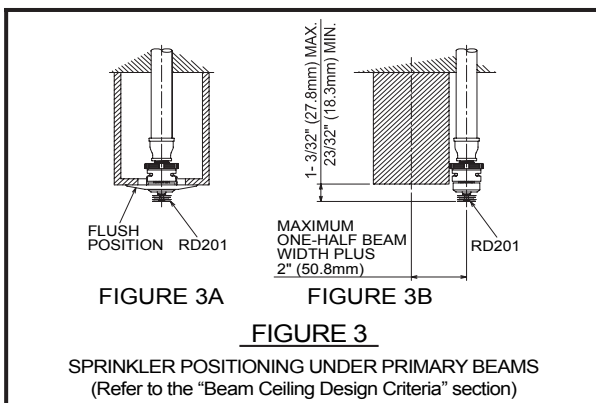

Primary and Secondary Beam Types.

Solid surface, solid or hollow core, combustible or non-combustible.

Primary and Secondary Beam Positioning.

Directly attached to the underside of a combustible or non-combustible smooth ceiling at any elevation.

Primary Beam Cross-Section.

Maximum depth of 14 inches and the maximum width is unlimited. The cross-sectional shape of the primary beam may be rectangular to circular.

Secondary Beam Cross-Section.

Maximum depth to be no greater than the primary beam and the maximum width is unlimited. The cross-sectional shape of the secondary beam may be rectangular to circular.

Primary Beam Spacing.

The primary beams (Fig. 4A) are to be 3 ft.-4 in. to 6 ft. from the compartment wall to center of the nearest beam and from center to center between beams.

Secondary Beam Spacing.

The secondary beams principally run perpendicular to the primary beams. Secondary beams of a depth equal to the primary beam must be placed so that the beam pockets created by the primary beams do not exceed 20 feet in length (Fig. 4B).

NOTE

When the beam pockets created by the primary beams exceed 20 feet in length, the installation will require the use of secondary beams as described above. Otherwise, secondary beams need not be present. Secondary beams of a cross-sectional depth greater than one-quarter the depth of the primary beams are to be a minimum of 3 ft.-4 in. from the compartment wall to center of the nearest beam and from center to center between beams (Fig. 4C). Secondary beams of a cross-sectional depth no greater than one-quarter the depth of the primary beams may be placed at any compartment wall to center of the nearest beam distance and from any center to center distance between beams (Fig. 4C).

Lintels.

Lintels over doorways exiting the compartment must be present. The minimum height for the lintels is 8 inches or no less than the depth of the Primary Beams, whichever is greater.

Sprinkler Types.

The Model ZN-RES (RD201), 162 °F, Flush Pendent Residential Sprinklers.

Sprinkler Coverage Area and Hydraulic Design.

The sprinkler coverage areas and hydraulic design criteria as presented in the Table A for "Horizontal Ceilings" are to be applied.

Sprinkler Position.

The bottom of heat collector to bottom of primary beams for the Model ZN-RES (RD201) Flush Pendent Sprinklers is to be 23/32 to 1- 3/32 inches (Fig. 3A). The vertical centerline of the Model ZN-RES (RD201) Flush Pendent Sprinklers is to be no greater than half the primary beam cross-sectional width plus 2 inches from the centerline of the primary beam (Fig. 3B).

NOTE

Core drilling of beam to allow the installation of sprinkler drops requires consulting with a structural engineering. Where core drilling is not permitted, the previously stated sprinkler position criteria for the Model ZN-RES (RD201) Pendent Sprinklers allows for the sprinkler drop to be placed adjacent to the primary beam.

Beam and Soffit Arrangements.

A soffit is permitted to be placed around the perimeter of a compartment with the beam arrangement within the soffit area (Fig.5). The cross-section of the soffit may be any size as long as it does not create an obstruction to water distribution per the obstruction rules of NFPA 13 for residential sprinklers. When soffits are present, the previously provided 3 ft.- 4 in. to 6 ft. "compartment wall to adjacent beam" distance for the primary and secondary beams is to be measured from the face of the soffit as opposed to the compartment wall.

Continued Overleaf
Page 3 of 7

NOTE

Although the distance to the beams is measured from the face of the soffit, the sprinkler coverage area is to be measured from the compartment wall.

ALL FIGURES:
DISTANCES ARE
MEASURED TO
COMPARTMENT
WALL FACES AND
TO CENTERLINES
OF BEAMS.

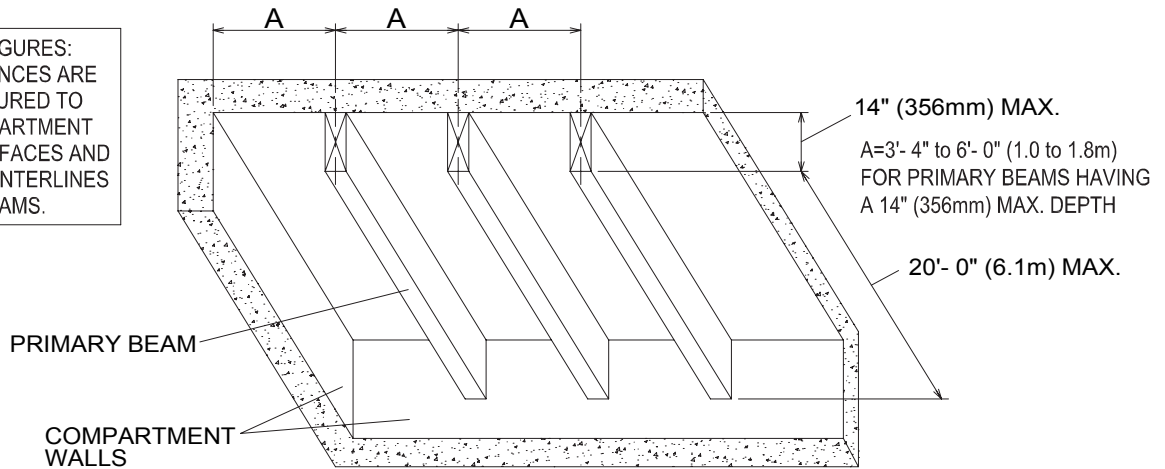

FIGURE 4A. PRIMARY BEAM SPANS UP TO 20'-0" (6.1m)

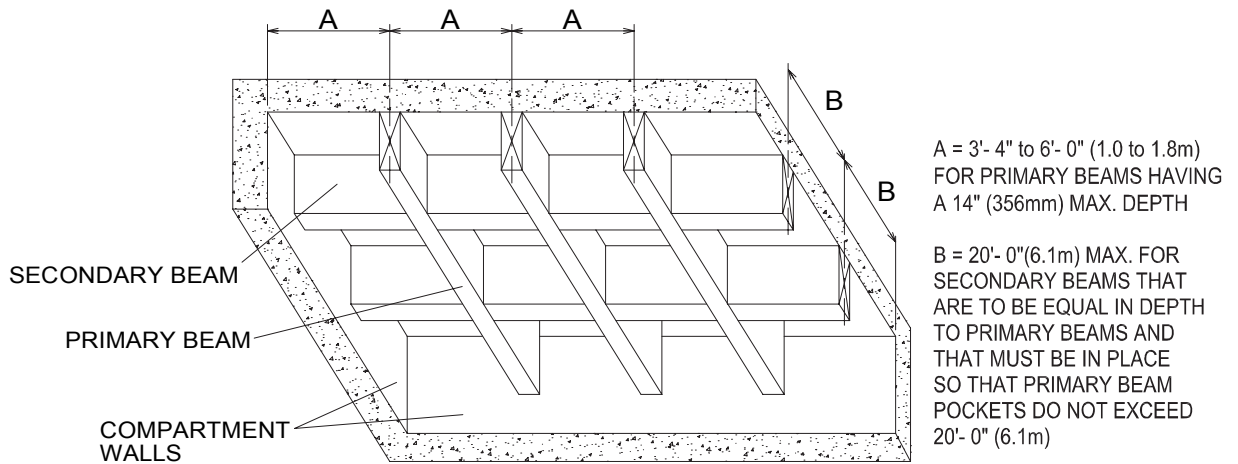

FIGURE 4B. PRIMARY BEAM SPANS GREATER THAN 20'-0" (6.1m)

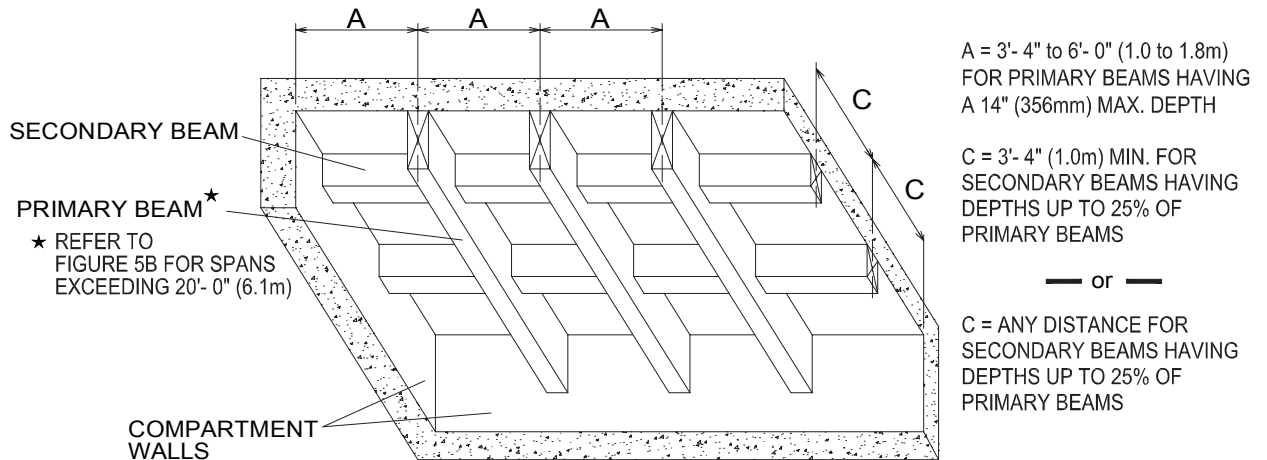

FIGURE 4C. COMBINATIONS OF PRIMARY AND SECONDARY BEAMS

FIGURE 4
BEAM ARRANGEMENTS
(Refer to the "Beam Ceiling Design Criteria" section)

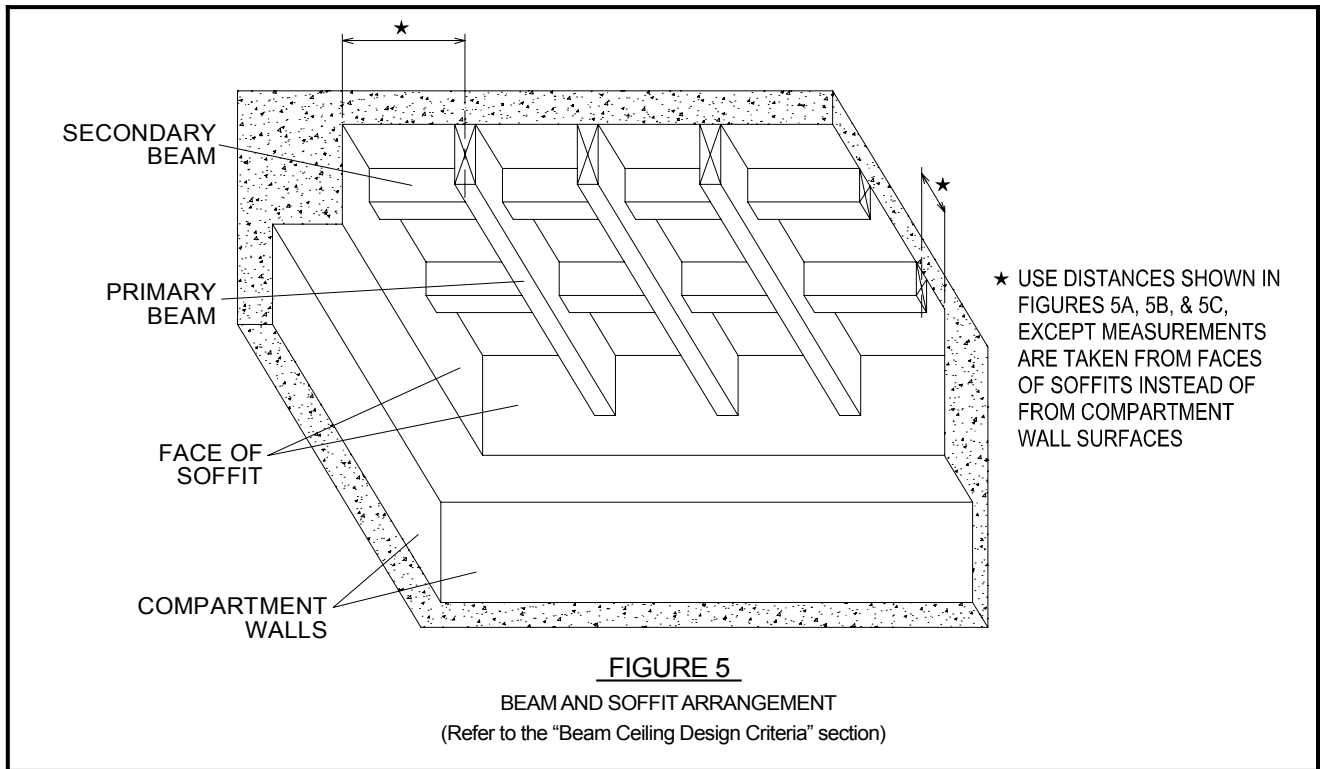

FIGURE 5
BEAM AND SOFFIT ARRANGEMENT
(Refer to the "Beam Ceiling Design Criteria" section)

Installation

The Model ZN-RES must be installed in accordance with the following instructions:

NOTES

Do not use sprinklers which have been subjected to potential mechanical damage. Do not use sprinklers which show deformation or cracking in either the sprinkler or protection cap.

The Protective Cap must remain on the sprinkler during installation and until the ceiling installation is completed. The Protective Cap must be removed to place the sprinkler in service.

A leak tight 1/2-inch NPT sprinkler joint should be obtained with a torque of 7 to 14 ft.lbs. (9.5 to 19.0 Nm). A maximum of 21 ft.lbs. (28.5 Nm) of torque is to be used to install sprinklers. Higher levels of torque may distort the sprinkler inlet with consequent leakage or impairment of the sprinkler.

Do not attempt to compensate for insufficient adjustment in an Escutcheon Plate by under- or over-tightening the sprinkler. Readjust the position of the sprinkler fitting to suit.

Installing procedure

Step 1.

The sprinkler must be installed only in the pendent position and with the Sprinkler waterway centerline perpendicular to the mounting surface.

Step 2.

Install the sprinkler fitting so that the distance from the face of the fitting to the mounting surface will be nominally 1-inch (25.0mm) for Short body and 1- 5/32 inch for Regular body as shown in Figure 6.

Step 3.

With pipe thread sealant applied to the pipe threads, hand tighten the Sprinkler into the sprinkler fitting.

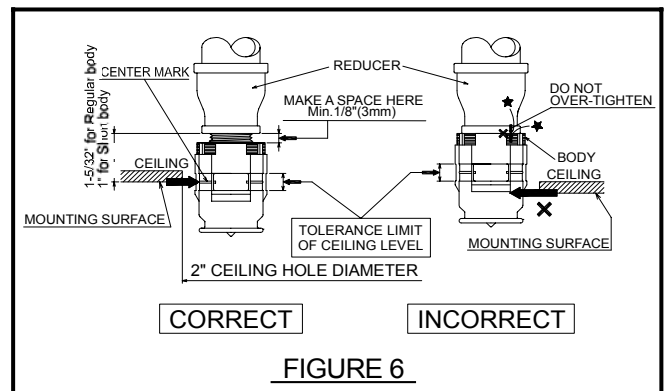

Step 4.

Wrench tighten the Sprinkler using only the Sprinkler Socket or Wrench & Socket Combination (Ref. Figure 7). The wrench recess of the Socket is to be applied to the sprinkler wrenching area (Ref. Figure 7).

Continued Overleaf
Page 5 of 7

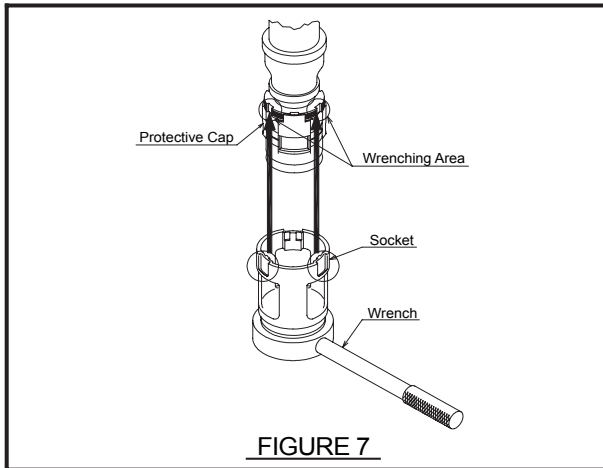

Step 5.

Use the "tolerance limit of ceiling level" indicator on the Protective Cap to check for proper installation height (Ref. Figure 6). Relocate the sprinkler fitting as necessary. If desired the Protective Cap may also be used to locate the center of the clearance hole by gently pushing the ceiling material against the center point of the Cap.

Step 6.

After the ceiling has been completed with the 2-inch (50mm) diameter clearance hole, use the Protective Cap Removal Tool (Ref. Figure 8) to remove the Protective Cap and then push on the Escutcheon until its flange just comes in contact with the ceiling (Ref. Figure 9 & Figure 10).

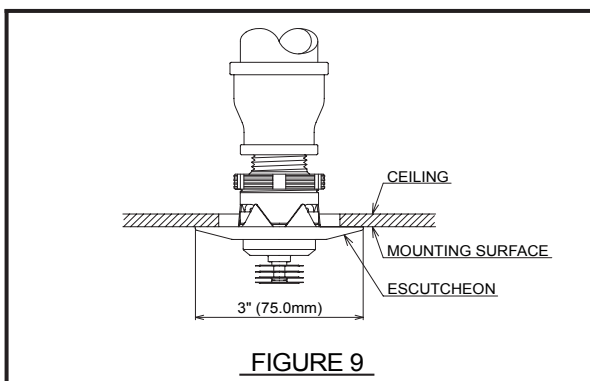
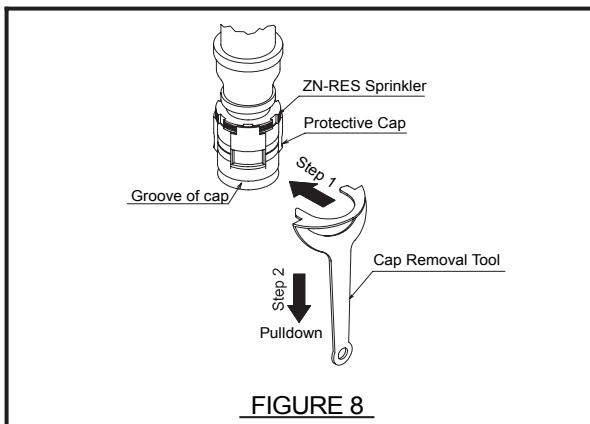

Do not continue to push on the Escutcheon such that it lifts a ceiling panel out of its normal position. If the Escutcheon cannot be engaged with the Sprinkler, or the Escutcheon cannot be engaged sufficiently to contact the ceiling, relocate the sprinkler fitting as necessary.

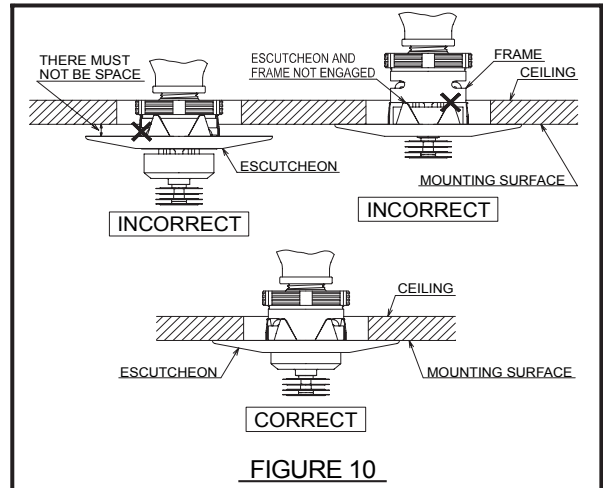

Care and Maintenance

The Model ZN-RES must be maintained and serviced in accordance with the following instructions:

NOTES

Wet pipe sprinkler systems must be maintained at a minimum temperature of 40 °F / 4 °C to prevent freezing and bursting of the pipe and/or sprinklers.

Automatic sprinklers are not to be tested with a heat source. Operation of the heat responsive element can result.

Absence of an Escutcheon Plate may delay the time to sprinkler operation in a fire situation.

Before closing a fire protection system main control valve for maintenance work on the fire protection system, which it controls, permission to shut down the affected fire protection system must be obtained from the proper authorities and all personnel who may be affected by this action must be notified.

Do NOT enclose sprinklers within drapes, curtains, or valances.

Do NOT hang anything from the sprinklers.

Do NOT cleanse the sprinklers with soap and water, detergents, ammonia, cleaning fluids, or other chemicals. Remove dust, lint, cobwebs, cocoons, insects, and larvae by gently brushing with a feather duster or gently vacuuming with a soft bristle (i.e., dusting) brush attachment.

Exercise suitable safety precautions in the use and storage of highly flammable materials. The rapid rate of fire development and spread of which can be caused by such materials can reduce the ability of the sprinkler system to aid in the control of a fire in which they are involved.

Sprinklers, which are found to be leaking or exhibiting visible signs of corrosion, must be replaced.

Automatic Sprinklers must never be shipped or stored where its temperature will exceed 100°F / 38°C and they must never be painted, plated, coated, or otherwise altered after leaving the factory. Modified or over heated sprinklers must be replaced.

Care must be exercised to avoid damage to the sprinklers-before, during, and after installation. Sprinklers damaged by dropping, striking, wrench twist / slippage, or the like, must be replaced.

The model ZN-RES must only be replaced with pendent sprinklers which are listed for residential fire protection service and which have the same nominal K-factor, the same coverage area, and the same or lower flow

ratings (as indicated under "Hydraulic Design Criteria").

When remodeling, such as by adding false beams or light fixtures or changing the location of compartment walls, first verify that the new construction will not violate the installation requirements of the applicable standards of NFPA. Alter the new construction and/or the sprinkler system to suit the requirements of this document and the applicable standards of NFPA.

The owner is responsible for the inspection, testing, and maintenance of their fire protection system and devices in compliance with this document, the applicable standards of the National Fire Protection Association (e.g., NFPA 25), and the standards of any other authorities having jurisdiction. The installing contractor or sprinkler manufacturer should be contacted relative to any questions.

It is recommended that automatic sprinkler systems be inspected, tested, and maintained by a qualified Inspection Service in accordance with NFPA 25.

Order Procedure

Please Specify:

Sprinkler Head:

RD201, Model ZN-RES K=4.2, Residential Flush Pendent Sprinkler

Finishes:

White Paint, Black Paint, Dark Brown Paint, and Chrome Plate.

Escutcheon:

Escutcheon for ZN-RES Flush Pendent Series.
(O. D. 3inch/75mm)

Finishes:

White Paint, Black Paint, Dark Brown Paint, and Chrome Plate.

Accessories:

- Socket for Model ZN-RES
- Wrench & Socket for Model ZN-RES
- Protective Cap Removal Tool for Model ZN-RES

Warnings

The Model ZN-RES Residential Flush Pendent Sprinklers described herein must be installed and maintained in compliance with this document, as well as with the applicable standards of the National Fire Protection Association, in addition to the standards of any authorities having jurisdiction. Failure to do so may impair the integrity of these devices.

Because of the above cited stipulations and the varied nature of residential type architecture, there will be some compartment designs which cannot be fully sprinklered in accordance with the recommendations of NFPA 13, 13D, or 13R, In the event of this condition, consult the authorities having jurisdiction for guidance and approval.

It is the responsibility of the installing contractor to provide a copy of this document to the owner or his representative, and in turn, it is the obligation of the owner to provide a copy of this document to a succeeding owner.

The owner is responsible for maintaining their fire protection system and devices in proper operating condition. The installing contractor or sprinkler manufacturer should be contacted relative to any questions.