

### Commercial Flat Concealed Sprinkler, Pendent Quick & Standard Response, Standard coverage Model: RD105 (RD-CN-QR), K=5.6

#### General Description

The Model RD105 Commercial Flat Concealed Sprinklers are automatic sprinklers of the compressed fusible solder type. These are decorative and quick/standard response. The frame of the sprinkler hides the deflector, gasket, etc., which is in turn concealed above the ceiling by the cover plate assembly. The cover plate has a flat profile, and its diameter is extremely small. The push-on/thread-on, thread-off design of the concealed cover plate assembly allows easy installation of the cover plate. Therefore, the Model RD105 should be your first choice when aesthetics is the major consideration for ultimate appeal and unbeatable performance is desired.

They are to be used in wet pipe sprinkler systems per NFPA 13 or as required by the Authority having jurisdiction.



The Model RD105 has a 5.6 (80) K-factor. For extended installation flexibility, the Model RD105 provides 3/8 inch (9.0mm) vertical adjustment. This adjustment in installation decreases the need for precise cutting of the pipe that drops to the sprinkler and allows for a perfect fit with a range of pipe lengths. The heat sensitivity and water distribution design of Model RD105 allows for an increased chance of occupants' escape or evacuation in case of fire. However, fire sprinkler systems are not a substitute for fire safety awareness or fire safety construction required by building codes.

#### Warnings

The Model RD105 must be installed and maintained in accordance with the rules stated herein as well as in compliance with the applicable standards of the National Fire Protection Association regulations and the standards of any other authorities having jurisdiction.

In the event of this condition, consult the Authorities Having Jurisdiction for guidance and approval.

Failure to do so may impair the integrity of these devices.

It is the responsibility of the installing contractor to provide a copy of this document to the owner or his representative, and in turn, it is the obligation of the owner to provide a copy of this document to a succeeding owner. The owner is responsible for maintaining their fire protection system and devices in proper operating condition. The installing contractor or sprinkler manufacturer should be contacted with any related questions.

#### Technical Data

Approvals:

**cUL<sub>us</sub> Listed / as Quick Response  
FM Approved / as Standard Response**

Sprinkler Identification Number (SIN): **RD105**

Maximum Working Pressure: **175psi (12.1bar)**

Discharge Coefficient (Nominal K-Factor):  
**K=5.6 GPM/psi<sup>1/2</sup> (80.6 LPM/bar<sup>1/2</sup>)**

Temperature Rating:

**162°F/72°C/Sprinkler with 140°F/60°C/Cover Plate  
205°F/96°C/Sprinkler with 162°F/72°C/Cover Plate  
(cUL<sub>us</sub> Listed only)**

Vertical Adjustment: **3/8 inch (9.0 mm)**

Cover Plate Finishes:  
**White Painted, Nickel Plated or  
Any Color (Choose a color of acceptable colors)**

Physical Characteristics: **Ref. Figure 1**

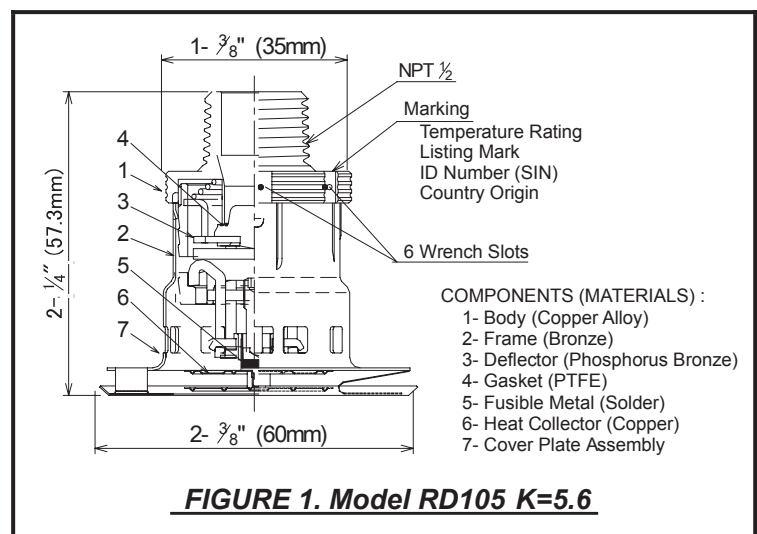

**Continued Overleaf  
Page 1 of 6**

## Operation

In case of fire, the solder component that holds together the Cover Plate and the Retainer melts and as a result the Cover Plate is released. The two Heat Collectors are exposed and when sufficient heat from the fire is recorded, internal components of the sprinkler separate. This leads to the dropping of the Deflector into its operating position, allowing the water discharge to be distributed over the fire. (Ref. Figure 2)

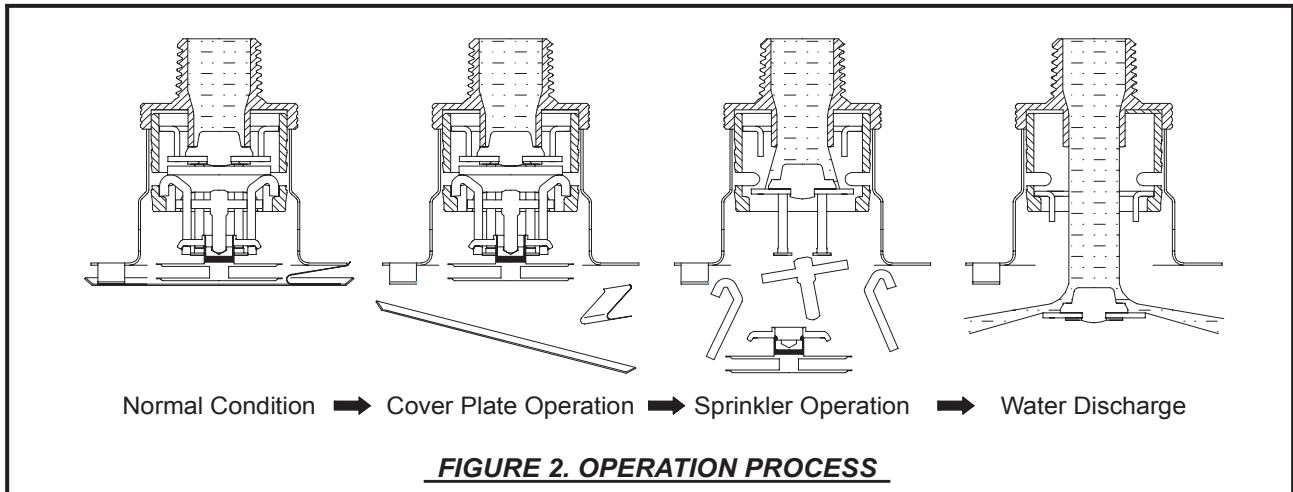

## Design Criteria

The Model RD105 sprinklers are listed by UL and cUL as quick response / standard coverage for use in accordance with NFPA standard, and FM Approved as a Standard Response, No-corrosive Atmosphere sprinkler. The herein stated rules for use and installation of the Model RD105 are provided by the manufacturer and must be strictly implemented for safe and full results.

## Notes

Fire Sprinkler Systems should only be designed and installed by individuals who are completely familiar with automatic sprinkler system design, installation procedures, and techniques.

Several criteria may apply to the installation and usage of each sprinkler. Consequently, it is recommended that the sprinkler system designer review and develop a working understanding of the complete list of criteria prior to initiating the design of the sprinkler system.

Questions concerning sprinkler installation and usage criteria, which are not covered by the following instructions, should be submitted to Rapidrop. Include sketches and technical details as appropriate.

In some instances, the requirements of this document may concern specifications which are more stringent and which take precedence over those specified in NFPA 13 or by the authority having jurisdiction.

The Model RD105 must not be used in applications where the air pressure above the ceiling is greater than that below.

The spray from the sprinkler is distributed radially outward and downward from the sprinkler deflector. Consequently, the sprinklers must be located such that there will be no blind spaces shielded from spray by partitions, room dividers, overhangs or other parts of the dwelling structure.

The number of sprinklers within each compartment (as defined by NFPA 13) must be kept as small as possible. Do NOT use more sprinklers than necessary to cover a particular space.

Use only the Cover Plate provided with the Model RD105. The sprinkler must be secured in place by firmly fastening the sprinkler system piping to the structure. If the sprinkler is not properly secured in position, reaction forces resulting from sprinkler operation could alter its orientation and its water distribution pattern.

### **Obstruction to Water Distribution**

**Locations of sprinklers must follow the obstruction rules of NFPA 13.**

## General Service Conditions

The Model RD105 must only be utilized in WET PIPE sprinkler systems per NFPA 13 or other rules of the Authority Having Jurisdiction.

## Operational Sensitivity Criteria

For proper operational sensitivity, the Model RD105 must be installed beneath a solid ceiling having a smooth or textured surface.

## Heat Source Criteria

Refer to NFPA 13 for the requirements relating to the prevention of possible activation of the Heat Responsive Element of Model RD105, due to exposure to a heat sources other than an actual fire.

## Precautionary Warnings for Corrosive Environments

The Model RD105 should not be installed where they may be subjected to a corrosive environment including the following:

### (1) Chlorine ion and Chloride environment.

Stress corrosion cracking may be caused by exposure to environments with Chlorine ion and Chloride. Exposure to this environment may result in sprinklers operating under Non-Fire conditions or Not Operating when exposed to an actual fire.

### (2) Sprinkler system piping with Copper.

Sprinkler systems should be constructed in compliance with the applicable standards and the requirements for the copper piping when copper piping is used in the sprinkler system. (Reference standards NFPA 13, ASTM B813, B828, and CDA (Copper Development Association) – Solder Joint)

All residual flux must be removed from the interior and exterior of copper piping by thoroughly flushing before installation of the Sprinkler Heads. Otherwise, residues of flux may cause corrosion and leakage in the sprinkler system.

## Installation

The Model RD105 must be installed in accordance with the following instructions.

## Notes

**Do not use any sprinklers which have been subjected to potential mechanical damage. Do not use any sprinklers which show deformation or cracking in either the Sprinkler or the Protective Cap.**

**Prior to installation, sprinklers should be maintained in the original cartons and packaging until used to minimize the potential for damage to sprinklers that would cause improper operation or non-operation.**

**The Protective Cap must remain on the sprinkler during installation and until the ceiling installation is completed. The Protective Cap must be removed to place the sprinkler in service.**

**Use a torque of 7 to 14 ft.lbs (9.5 to 19.0Nm) to achieve a 1/2 inch NPT sprinkler joint. A maximum of 21 ft.lbs. (28.5 Nm) of torque is to be used to install sprinklers. If you exceed the recommended maximum torque, this could result in damage to the sprinkler inlet, which may lead to leakage from the sprinkler.**

**In case of insufficient adjustment in Cover Plate installation, do not try to overly tighten, screw the sprinkler too loosely or make any modification to the cover plate assembly. Readjust the sprinkler fitting for a better fit.**

## Installing Procedure

### Step 1

The installation requirements for the sprinkler are as follows: to be installed only in the pendent position with the waterway perpendicular to the ceiling. Install the sprinkler fitting so that the distance from the face of the fitting to the mounting surface will be nominally 1- 7/8 inch (47.6 mm) as shown in Figure 3.

### Step 2

With pipe thread sealant applied to the threads, hand tighten the sprinkler into the sprinkler fitting. Then tighten it with the Sprinkler Socket or Wrench & Socket Combination (Ref. Figure 4). The grooves of the Socket must fit perfectly with the grooves on the Sprinkler for proper installation (Ref. Figure 4).

**Continued Overleaf  
Page 3 of 6**

### Step 3

If desired the Protective Cap may also be used to locate the center of the clearance hole by gently pushing the ceiling material against the center point of the Protective Cap. Before the installation of the ceiling, the sprinkler installation can be started with the 2 inch (50 mm) diameter clearance hole (Ref. Figure 3). Use the "Tolerance Limit of Ceiling Level" indicator on the Protective Cap to check for proper installation height (Ref. Figure 3).

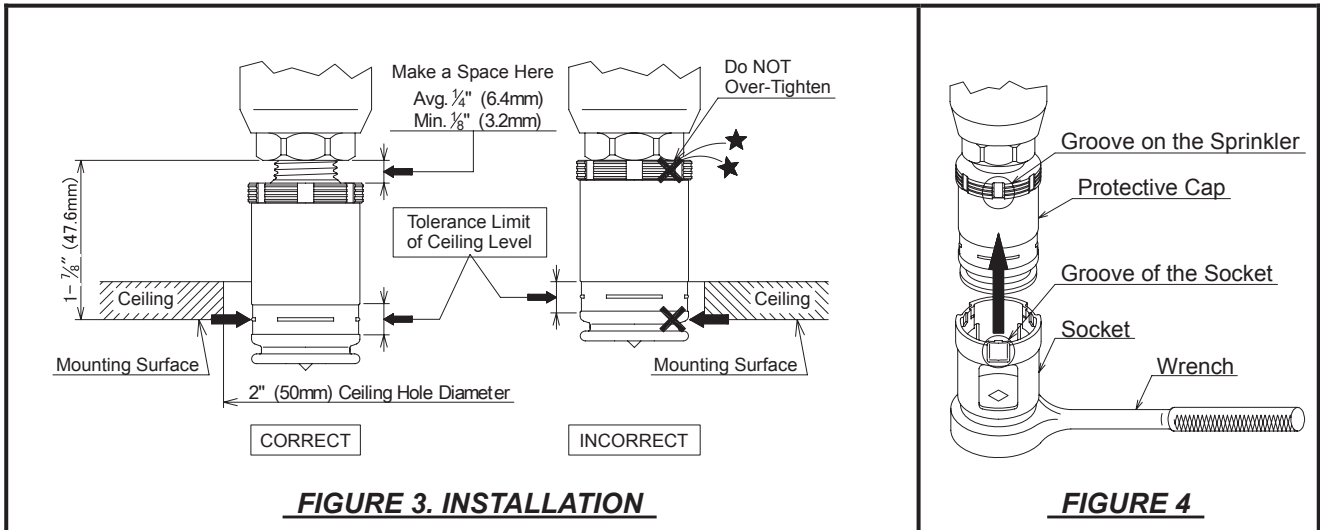

### Step 4

Use the Protective Cap Removal Tool to remove the Protective Cap (Ref. Figure 5) and then push/screw a Cover Plate Assembly on the Frame of the Sprinkler by hand until its flange just comes in contact with the ceiling (Ref. Figure 6 and Figure 7). Stop tightening the Cover Plate Assembly once the flange has come in contact with the ceiling. If the ceiling has been lifted from its normal position in the process of tightening of the Cover Plate Assembly, readjust the cover plate assembly as necessary. If the flange of the Cover Plate Assembly cannot come in contact with the ceiling sufficiently, readjust the sprinkler fitting as necessary. When properly installed, there is a nominal 1/8 inch (3.2mm) air gap between the lip of the Cover Plate and the ceiling, as shown in Figure 6

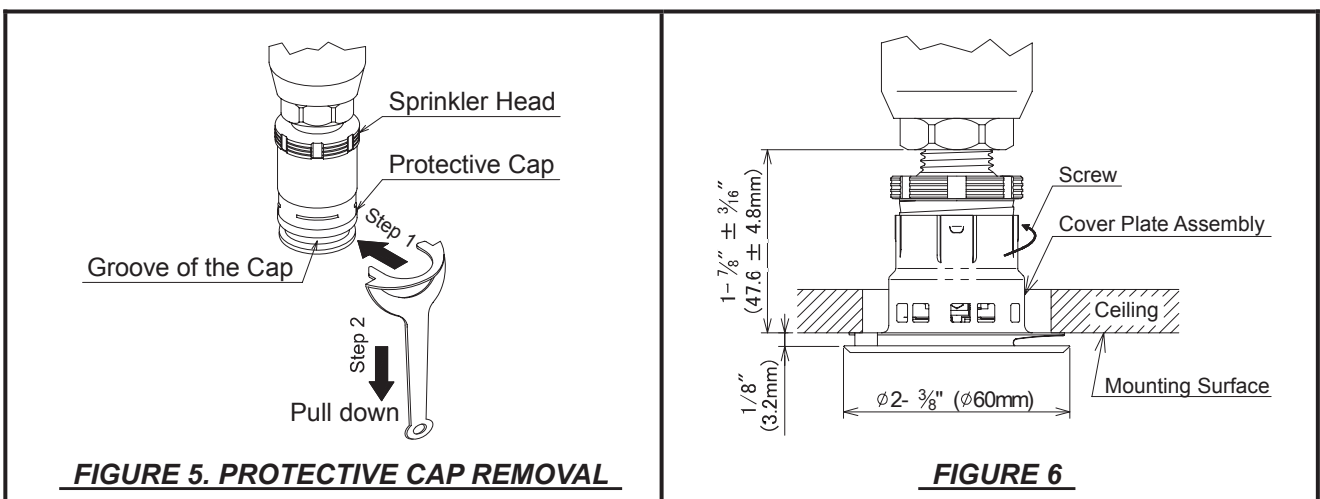

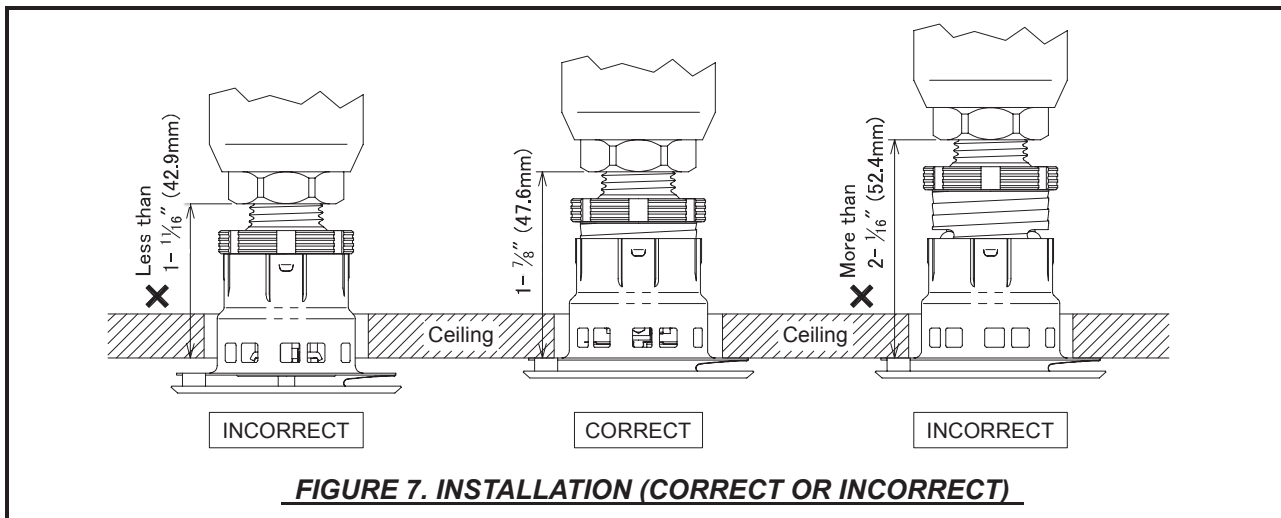

## Care and Maintenance

The following instructions must be implemented for the maintenance and service of the Model RD105

### Notes

*Wet pipe sprinkler systems must be maintained at a minimum temperature of 40°F / 4°C to prevent freezing and bursting of the pipe and/or sprinklers.*

*Automatic sprinklers are not to be tested with a heat source. Operation of the heat responsive element can result.*

*Absence of a Cover Plate Assembly may delay the response time of the sprinkler in case of fire.*

*Install the cover plate assembly properly, as shown in Figure 6. Improper installation of the cover plate assembly may cause improper operation or non-operation.*

*If the ceiling is to be repainted after the installation of the Sprinkler, care must be exercised to ensure that the new paint does not seal off any of the air gap.*

*Factory painted Cover Plates must not be repainted. They should be replaced, if necessary, by factory painted cover plates. Non-factory applied paint may adversely delay or prevent sprinkler operation in case of a fire.*

*Do not pull the Cover Plate. Separation may result.*

*In preparation for maintenance of the fire protection system, permission to close the main control valve must be obtained from the proper authorities and all affected by this action parties must be informed before the maintenance session can commence.*

*Do NOT enclose any sprinklers within drapes, curtains, or valances.*

*Do NOT hang anything from the sprinklers.*

*Do NOT clean the sprinklers with soap and water, detergents, ammonia, cleaning fluids, or other chemicals. Remove dust, lint, cobwebs, cocoons, insects, and larvae by gently brushing with a feather duster or gently vacuuming with a soft bristle (i.e., dusting) brush attachment.*

**Continued Overleaf**  
**Page 5 of 6**

## Notes continued

*Exercise suitable safety precautions in the use and storage of highly flammable materials. The rapid rate of fire development and spread of these materials can reduce the ability of the sprinkler systems to aid in the control of a fire involving such hazards.*

Leaking or corroded sprinklers must be replaced.

Automatic Sprinklers must never be shipped or stored where the temperature exceeds 100°F / 38°C.

Automatic sprinkler must never be physically altered, such as painted, plated, or coated, once shipped from the factory. If the sprinklers have been in any way modified, they must be replaced.

Great caution must be applied to prevent damage to the sprinklers at all stages - before, during, and after installation. Damaged units, as a result of dropping, hitting, over-tightening, or wrench slippage, must be replaced.

When remodeling, such as by adding false beams or light fixtures or changing the location of compartment walls, first verify that the new construction will not violate the installation requirements of the applicable standards of NFPA. Alter the new construction and/or the sprinkler system to suit the requirements of this document and the applicable NFPA regulations.

The owner is responsible for the maintenance of the sprinkler system, including inspection and testing, its compliance with this documents, as well as the standards of the National Fire Protection Association (e.g., NFPA 25), and the regulations of any other authorities having jurisdiction. The owner should direct any questions regarding the above rules and regulations to the installing contractors or the sprinkler manufacturer. It is recommended that automatic sprinkler systems be inspected, tested, and maintained by a qualified Inspection Service in accordance with NFPA 25.

## Order Procedure

When placing an order, please contact a local distributor with the following information (Model Name, Specify, Temp. and Finish).

### Sprinkler

- Model: RD105, Quick & Standard Response, Standard Coverage, Flat Concealed Sprinkler, Pendent,

Temp.	162°F / 72°C	205°F / 96°C
Model		
RD105 K5.6	○	○*1

### Cover Plate Assembly

- (2-3/8inch (60mm), Order Separately from Sprinkler)

Temp.	140°F / 60°C Cover Plate (for 162°F / 72°C Sprinkler Head)	162°F / 72°C Cover Plate (for 205°F / 96°C Sprinkler Head)
Finish		
White Painted Standard RAL 9010	○	○*1
Nickel Chrome Plated	○	○*1
Other colours available on request *2	○	○*1

\*1: cULus Listed Only

\*2: Choose one color of our acceptable color list. Regarding the color list information, please contact a local distributor.

### Tools for Installation of Model: RD105

- Socket for Model RD105
- Wrench & Socket for Model RD105
- Protective Cap Removal Tool for Model RD105