

# PIV200 Non Rising Stem Resilient Wedge Gate Valve

UL Listed / FM Approved

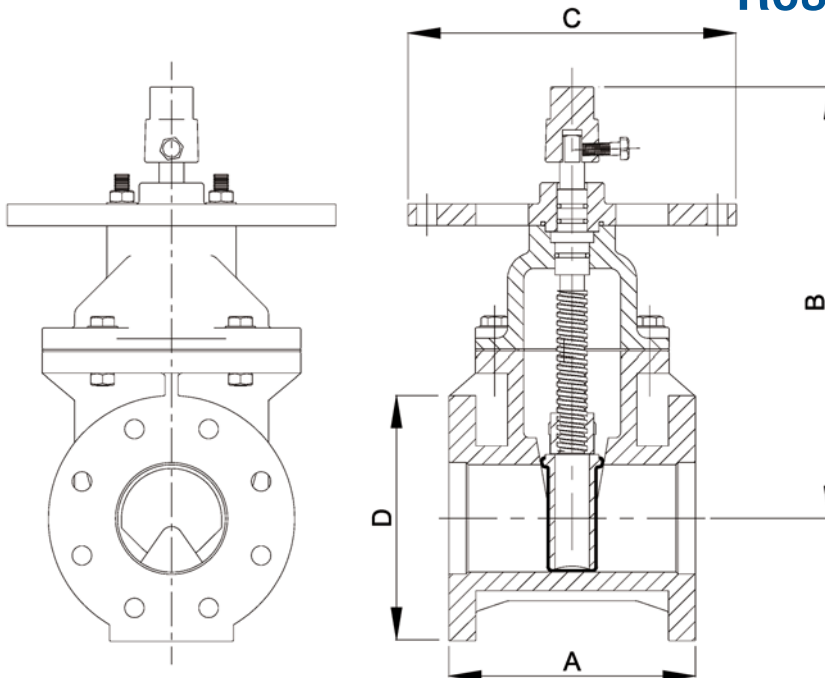

### Pressure & Rating

Max Working Pressure: 13.8 Bar

### Dimensions

Size	65 mm	80 mm	100 mm	150 mm	200 mm	250 mm	300 mm
A	190.5	203.0	229.0	267.0	292.0	330.0	356.0
B	265.0	335.0	385.0	460.0	570.0	650.0	770.0
C	-	-	305.0	305.0	305.0	305.0	305.0
D	178.0	190.5	228.6	279.4	343.0	406.4	483.0
Weight Kg	25.0	31.0	55.0	81.0	115.0	186.0	290.0

### Material Specification

Item	Material
Body	Cast Iron, ASTM A126 Class B
Wedge Disc	Cast Iron, ASTM A126 + EPDM Coated
Stem Nut	Bronze, ASTM B62 C83600
O Ring	EPDM
Stem	Stainless Steel, AISI 420
Gasket	EPDM
Bonnet	Cast Iron, ASTM 126 Class B
Thrust Washer	PTFE
Post Plate	Cast Iron, ASTM A126 Class B
Operating Nut	Ductile Iron, ASTM A536 65-45-12
Bolts & Nuts	Stainless steel

### Notes

1. Design and dimensions conform to AWWA C509
2. Flat Faced Flange drilled PN 16. Other flange types available on special order.
3. Fusion bonded epoxy coated inside and out.
4. Optional ASTM B16 Brass Stem available to order
5. Post indicator plates standard on 4" to 12" valves only

### Rapidrop Global