

(New Design) HRG 300 Grooved Butterfly Valve

August 2009

FM Approved / UL Listed

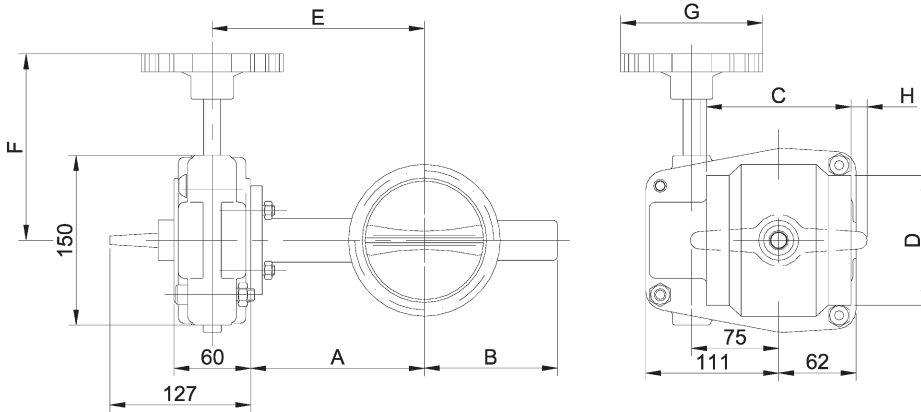

Pressure & Temperature

Max Working Pressure:	20.7 Bar
Max Test Pressure:	41.4 Bar
Max Working Temperature:	120°C

Factory installed Double Tamper Switch for indoor and outdoor use.

Dimensions

Size	Pipe O/D mm	A mm	B mm	C mm	D mm	E mm	F mm	G mm	H mm	Weight Kg
65 mm	73	105	85	96.4	73.0	135	135	128	-	9.0
65 mm	76	105	85	96.4	76.1	135	135	128	-	9.0
80 mm	89	112	92	96.4	88.9	142	135	128	-	9.8
100 mm	114	145	108	115.4	114.3	175	135	128	-	11.0
150 mm	165	179	145	132.4	165.1	209	193	220	6.8	17.4
150 mm	168	179	145	132.4	168.3	209	193	220	6.8	17.4
200 mm	219	204	170	147.4	219.1	234	193	220	24.2	22.8

Material Specification

Item	Material
Body	ASTM A-536 Nylon-11 Coated
Disc	ASTM A-536 EPDM Encapsulated
Upper & Lower Stems	AISI 420-SS
Worm Gear Shaft	AISI 410-SS
Housing	ASTM A-536
Hand Wheel	ASTM A-536
Flag Indicator	ASTM A-536
Shear Pin	ASTM A-510
Segment Gear	ASTM B-148 or B-584
Housing Gasket	EPDM Grade "E"
O-Rings (All)	EPDM Grade "E"