

GP 230 Wafer Butterfly Valve

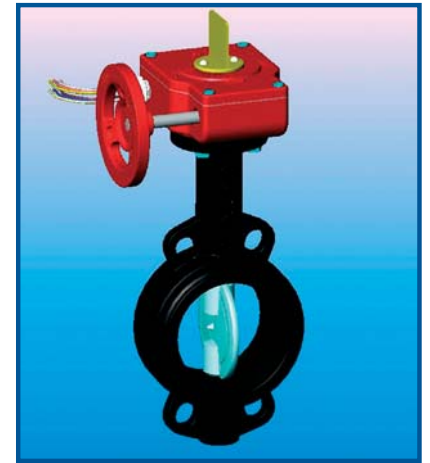
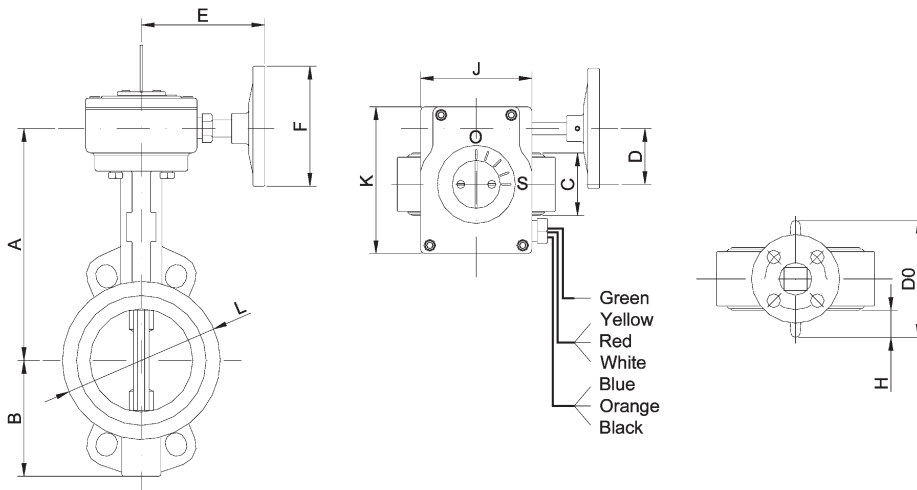

Pressure & Temperature

Max Working Pressure: 16 Bar
 Hydraulic Shell Test Pressure: 24 Bar
 Hydraulic Seat Test Pressure: 17.6 Bar
 20 Bar at: -10°C to 120°C
 Suitable Media: Water, Oil, Gas
 Rated at 20 Bar working pressure cold water only

Dimensions

Size	A mm	B mm	C mm	D mm	Do mm	E mm	F mm	K mm	J mm	H mm	L mm	Wt Kg.
50 mm	191	80	42	53	58	115	115	145	110	8	90	8.3
65 mm	203	91	45	53	73	115	115	145	110	14	110	8.3
80 mm	211	95	45	53	83	115	115	145	110	19	126	9.1
100 mm	230	115	50	53	102	115	115	145	110	26	154	10.2
150 mm	255	138	56	53	152	115	115	145	110	48	210	13.9
200 mm	271	170	60	80	202	175	165	200	160	71	265	24.7
250 mm	326	198	68	80	252	175	165	200	160	92	320	33.4
300 mm	366	240	80	80	302	175	165	200	160	111	370	42.3
350 mm	413	267	80	80	336	175	165	200	160	128	430	50.6

Material Specification

Item	Material	BS	ASTM
Body	Cast Iron	1452 Gr220	A126 Cl.B
Disc	Stainless Steel	1507 S31 C16	A351 CF8M
Shaft	Stainless Steel	970 416 S21	AISI 416
Bushings	PTFE		
Liner	EDPM		
O-rings	EDPM		

Notes

1. Conforms to BS EN 593, MSS SP-67
2. Bolt circles are carefully designed to fit the following flange types:
BS EN 1092 PN16, BS 10 D/E, ANSI 125
3. Top Flange conforms to ISO 5211/1
4. Gearbox supplied as standard with gear operator, position indicator and tamper switch