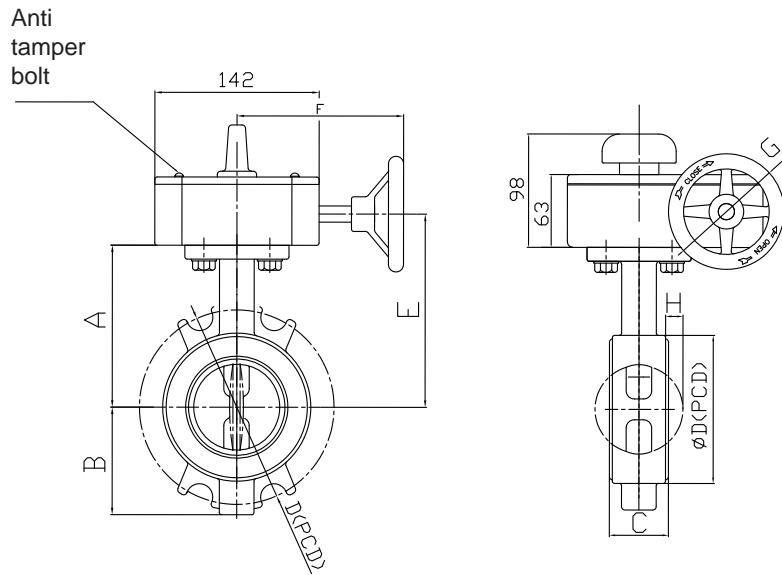

Fig 210 Wafer Butterfly Valve

FM Approved / UL Listed*



Description

- UL Listed & FM Approved
- Indoor & Outdoor use
- Internal Supervisory Switch
- Nylon - 11 Coated Ductile Iron Body
- EPDM Encapsulated Disc
- Sizes 2 1/2", 3", 4", 6" & 8"

Pressure & Temperature

- Max Working Pressure: 20.7 Bar
- Max Test Pressure: 41.4 Bar
- Max Working Temperature: 120°C

Dimensions

Size In	A mm (In)	B mm (In)	C mm (In)	D mm (In)	E mm (In)	F mm (In)	G mm (In)	H mm (In)	Weight Kg (lbs)
2 1/2"	130 (5.19)	87 (3.42)	46 (1.81)	145 (5.70)	161 (6.33)	144 (5.67)	100 (3.93)	8.2 (0.32)	9 (19.84)
3"	143 (5.63)	93 (3.66)	46 (1.81)	160 (6.3)	174 (6.85)	144 (5.67)	100 (3.93)	14.5 (0.57)	9.80 (21.60)
4"	156 (6.14)	109 (4.30)	52 (2.04)	190 (7.48)	187 (7.36)	144 (5.67)	100 (3.93)	22.7 (0.89)	11 (24.25)
6"	188 (7.40)	145 (5.70)	56 (2.20)	240 (9.45)	219 (8.62)	200 (7.87)	180 (7.09)	45.4 (1.78)	14.40 (31.74)
8"*	222 (8.74)	189 (7.44)	58 (2.30)	305 (12.01)	250 (9.84)	200 (7.87)	180 (7.09)	69.1 (2.72)	18.80 (41.45)

*Size 8" - UL Listed only. All other sizes are both FM Approved and UL Listed

Material Specification

Item	Material
Body	Ductile Cast Iron ASTM A-536 Nylon-11 Coated
Disc	Ductile Cast Iron ASTM A-536 EPDM Encapsulated
Upper & Lower Stems	AISI 410-SS
Worm Gear Shaft	AISI 410-SS
Housing	Ductile Cast Iron ASTM A-536
Worm Gear	AISI 410-SS
Flag Indicator	Ductile Cast Iron ASTM A-536
Hand Wheel	Ductile Cast Iron ASTM A-536
O Rings	EPDM
Shear Pin	ASTM A-510
Segment Gear	ASTM B-584
Switches	UL Listed, CE Verified

Switch Connection Diagram

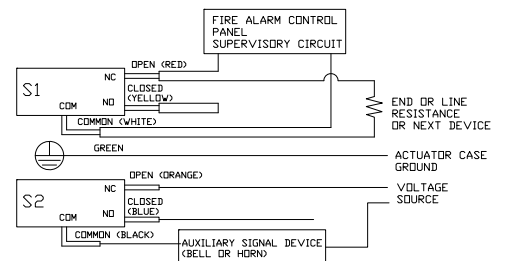

1. RATED : 5A-1/6HP-125/250VAC.
0.5A-125VDC, 0.25A-250VDC
2. SWITCH 1 : 2LEADS PER TERMINAL
SWITCH 2 : 1LEADS PER TERMINAL

FOR INDOOR & OUT INDOOR USE"