

Model EA Water Motor Alarm Gong

UL Listed/ FM Approved

TECHNICAL DATA :

| | |
|-------------------------|---|
| MODEL | 'EA |
| MOUNTINGTYPE | Type - A & Type - B |
| MAXIMUMWORKING PRESSURE | 12.3Kg./Sq.cm. (175 PSI) |
| CONNECTION | Inlet : 3/4" BSPT (3/4" NPT) Drain : 1" BSPT (1" NPT) |
| FACTORY TEST | At low flow - 0.35 Kg./sq.cm. (5 PSI) & At high flow - 7 Kg./sq.cm. (100 PSI) |
| GONG DIAMETER | 205mm (8") |
| GONG DEPTH | 50mm (2") |
| FINISH | Epoxy red powder coated |
| WEIGHT | 3.0Kg. |
| ORDERING INFORMATION | Model & Mounting Type |



SPRINKLER ALARM MODEL - GA EA

'RD' Sprinkler Alarm is a hydraulically driven mechanical bell. It does sound a continuous alarm when the sprinkler system operates. The impeller and drive shaft are energy efficient, made from light weight nonmetallic material and does not require any external lubrication. The gong, protection cover and motor housing are made of corrosion resistant aluminium alloy.

OPERATION

When the sprinkler system is activated by the fusing of one or more automatic sprinklers at fire condition the water flows through the Alarm / Deluge Valve and enter the sprinkler alarm through the nozzle, creating a high velocity jet which strikes the impeller causing the drive shaft and the striker arm assembly to rotate. The alarm arm assembly rotate and strikes to impact against the aluminium gong, producing a continuous alarm. The waste water then drains out through a 25NB drain outlet. It takes minimum 0.35 Kg./Sq.Cm. (5 PSI) pressure at the nozzle to cause an alarm.

DESIGN REQUIREMENT

Strainer is required in the Sprinkler Alarm line to protect the 3.2 mm nozzle in the water motor housing from clogging.

The alarm line pipe must be 20NB (3/4") size with 22.8

mtrs. (75 feet) maximum total length of pipe with minimum number of fittings. If the length of the pipe exceeds 22.8 mtrs. (75 feet), then higher size pipe must be used to reduce hydraulic friction loss. The Sprinkler Alarm should not be located more than 1.8 mtrs. (Six feet) above Alarm Valve / Deluge Valve.

MAINTENANCE

Qualified and trained person must commission the system. After few initial successful tests an authorised person must be trained to perform inspection and testing of the system.

Even though corrosion resistant material is used in the construction of the Sprinkler Alarm, it is suggested that the Sprinkler Alarm be examined and tested at regular intervals to ensure that the nozzle is free from obstruction and the impeller is free to rotate. The inspection should include the following :

1. Clean 20 NB (3/4 ") Strainer provided in the alarm line.
2. Open the 3/8" plug provided on the inlet of the Sprinkler Alarm and clean out any accumulated particles.
3. Detach the Gong, clean the internal surface and refit in proper sequence.
4. Activate the Sprinkler Alarm to verify clear and steady sound.

Model EA Water Motor Alarm Gong

UL Listed/ FM Approved

Sprinkler Alarm - EA Mounting Type - A

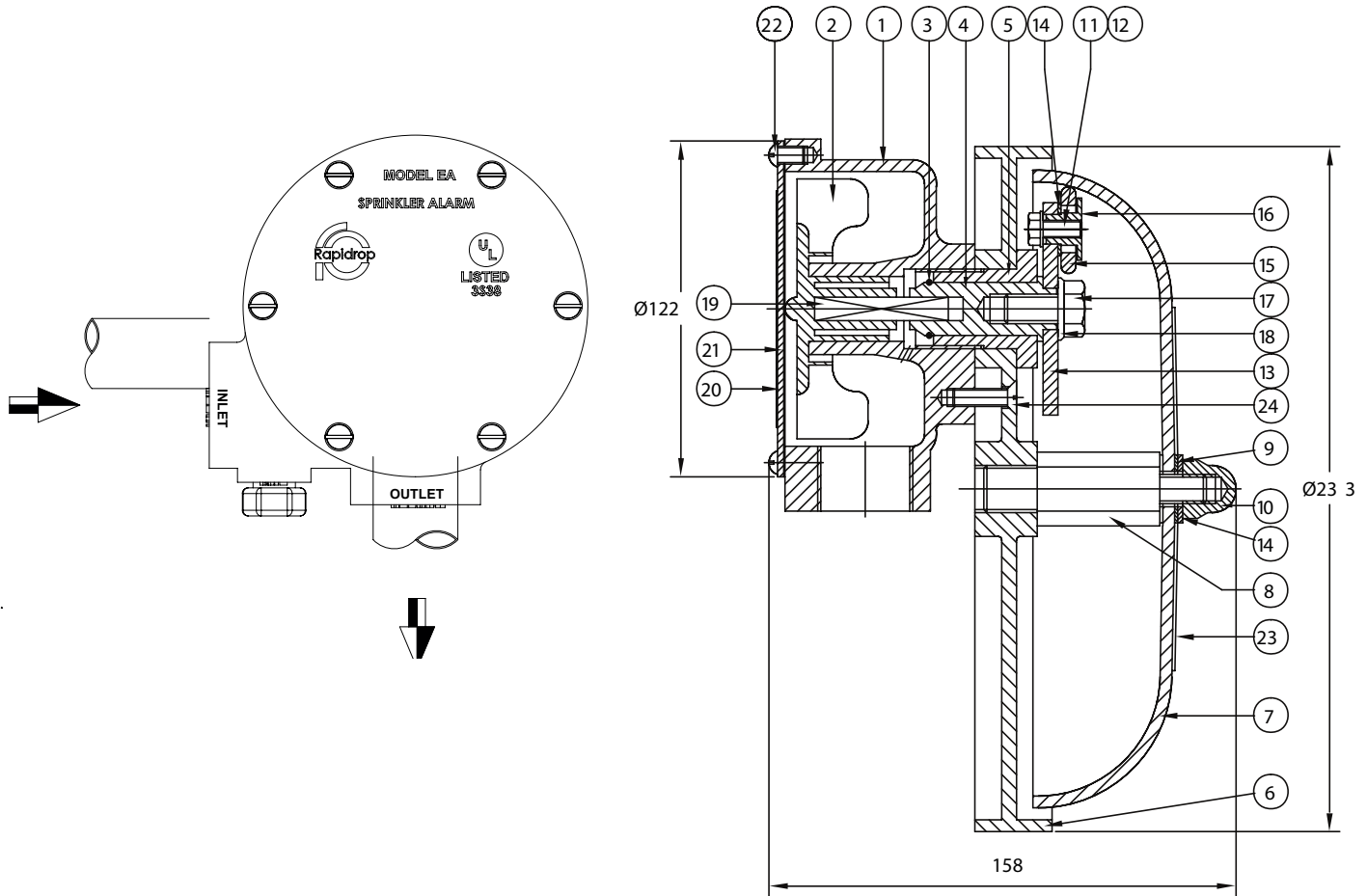

PART LIST

| ITEM NO. | CODE | DESCRIPTION | QTY. | MATERIAL |
|----------|------|---------------------|------|-----------------|
| 1 | 5001 | HOUSING | 1 | ALUMINIUM ALLOY |
| 2 | 5002 | PELTON WHEEL | 1 | DELRIN |
| 3 | 5003 | RETAINING RING | 1 | SS 316 |
| 4 | 5004 | DRIVE SHAFT ADAPTOR | 1 | DELRIN |
| 5 | 5005 | BUSH | 1 | ALUMINIUM ALLOY |
| 6 | 5006 | PROTECTION COVER | 1 | ALUMINIUM ALLOY |
| 7 | 5007 | GONG | 1 | ALUMINIUM ALLOY |
| 8 | 5008 | GONG POST | 1 | ALUMINIUM ALLOY |
| 9 | 5018 | NYLON WASHER | 2 | NYLON |
| 10 | 5009 | DOME NUT | 1 | ALUMINIUM ALLOY |
| 11 | 9106 | HEX. HED BOLT | 1 | PLATED STEEL |
| 12 | 5019 | WASHER | 1 | S.S. |
| 13 | 5010 | STRIKER ARM | 1 | ALUMINIUM ALLOY |

| ITEM NO. | CODE | DESCRIPTION | QTY. | MATERIAL |
|----------|------|-------------------|------|-----------------|
| 14 | 5011 | STRIKER WASHER | 1 | ALUMINIUM ALLOY |
| 15 | 5012 | STRIKER | 1 | FIBRE |
| 16 | 5013 | STRIKER BUSH | 1 | ALUMINIUM ALLOY |
| 17 | 5014 | STRIKER ARM BOLT | 1 | ALUMINIUM ALLOY |
| 18 | 5015 | STRKER ARM WASHER | 1 | ALUMINIUM ALLOY |
| 19 | 5024 | DRIVE SHAFT | 1 | ALUMINIUM ALLOY |
| 20 | 5016 | HOUSING COVER | 1 | ALUMINIUM ALLOY |
| 21 | 5017 | GASKET | 1 | NEOPRENE |
| 22 | 9029 | CH.HEAD BOLT | 6 | PLATED STEEL |
| 23 | 5020 | GONG STICKER | 1 | PVC |
| 24 | 9025 | SCREW | 1 | PLATED STEEL |

- All dimension in mm



Model EA Water Motor Alarm Gong

UL Listed/ FM Approved

Sprinkler Alarm - EA Mounting Type - B

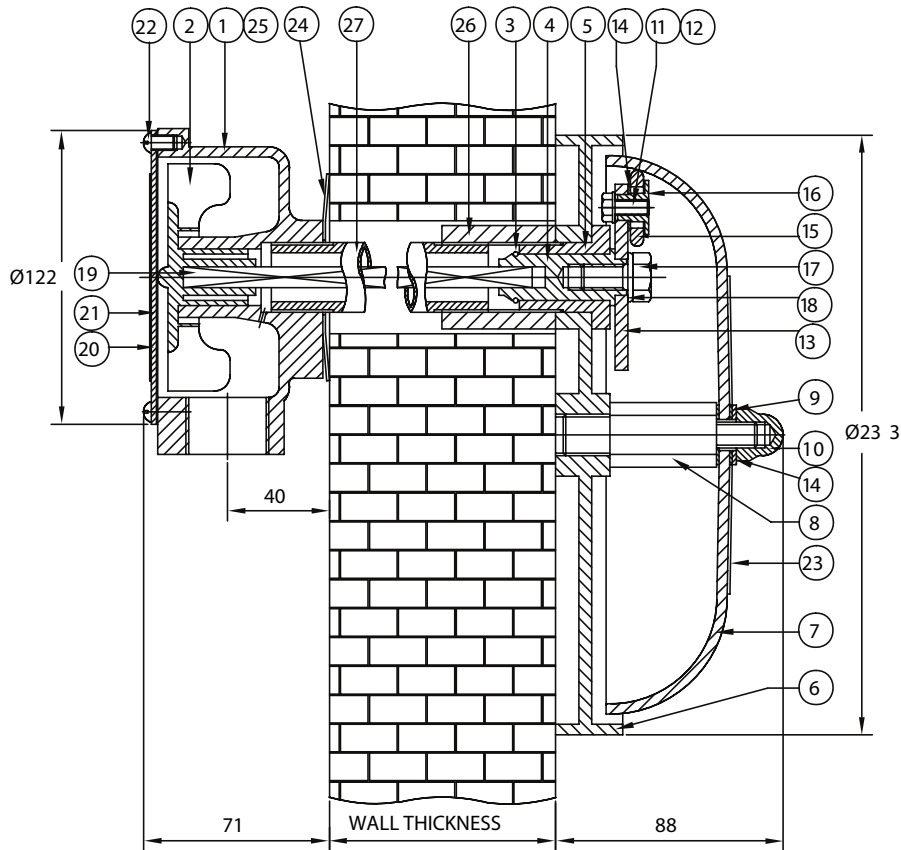

PART LIST

| ITEM NO. | CODE | DESCRIPTION | QTY. | MATERIAL |
|----------|------|---------------------|------|-----------------|
| 1 | 5001 | HOUSING | 1 | ALUMINIUM ALLOY |
| 2 | 5002 | PELTON WHEEL | 1 | DELTRIN |
| 3 | 5003 | RETAINING RING | 1 | SS 316 |
| 4 | 5004 | DRIVE SHAFT ADAPTOR | 1 | DELTRIN |
| 5 | 5005 | BUSH | 1 | ALUMINIUM ALLOY |
| 6 | 5006 | PROTECTION COVER | 1 | ALUMINIUM ALLOY |
| 7 | 5007 | GONG | 1 | ALUMINIUM ALLOY |
| 8 | 5008 | GONG POST | 1 | ALUMINIUM ALLOY |
| 9 | 5018 | NYLON WASHER | 2 | NYLON |
| 10 | 5009 | DOME NUT | 1 | ALUMINIUM ALLOY |
| 11 | 9106 | HEX. HEAD BOLT | 1 | PLATED STEEL |
| 12 | 5019 | WASHER | 1 | S.S. |
| 13 | 5010 | STRIKER ARM | 1 | ALUMINIUM ALLOY |
| 14 | 5011 | STRIKER WASHER | 1 | ALUMINIUM ALLOY |

| ITEM NO. | CODE | DESCRIPTION | QTY. | MATERIAL |
|----------|------|---------------------|------|------------------------|
| 15 | 5012 | STRIKER | 1 | FIBER |
| 16 | 5013 | STRIKER BUSH | 1 | ALUMINIUM ALLOY |
| 17 | 5014 | STRIKER ARM BOLT | 1 | ALUMINIUM ALLOY |
| 18 | 5015 | STRIKER ARM WASHER | 1 | ALUMINIUM ALLOY |
| 19 | 5027 | DRIVE SHAFT | 1 | ALUMINIUM ALLOY |
| 20 | 5016 | HOUSING COVER | 1 | ALUMINIUM ALLOY |
| 21 | 5017 | GASKET | 1 | NEOPRENE |
| 22 | 9029 | CH. HEAD BOLT | 6 | PLATED STEEL |
| 23 | 5020 | GONG STICKER | 1 | PVC |
| 24 | 5021 | WALL SUPPORT WASHER | 1 | MS |
| 25 | 5022 | PLUG | 1 | ALUMINIUM ALLOY |
| 26 | 5023 | COUPLING | 1 | STEEL |
| 27 | 5025 | SUPPORT PIPE | 1 | GI PIPE (BY INSTALLER) |

- All dimension in mm



Model EA Water Motor Alarm Gong

UL Listed/ FM Approved

INSTALLATION OF SPRINKLER ALARM

MODEL GEAIOUNTING TYPE - A

The Sprinkler Alarm with mounting Type-A is supplied pre-assembled. Connect the Alarm port of the Alarm valve or Deluge valve to the inlet of the sprinkler alarm assembly with 20NB (3/4") pipe with proper support. A 20NB (3/4") strainer is to be provided as close as possible to the Sprinkler Alarm assembly. Connect the 25NB (1") drain pipe to the housing, taking due care that the drain discharge is running to a safe location and keep the drain free from obstruction. A blocked drain discharge may create back pressure and prevent the Sprinkler Alarm from operating properly.

The 20NB (3/4") inlet and 25NB (1") drain pipe should be properly supported with the help of the bracket so that in turn proper support is available for the Sprinkler Alarm. The inlet and the drain pipe is to be preferably connected with an union for easy removal and re-fixing of the Sprinkler Alarm during maintenance.

The Sprinkler Alarm must be installed in accordance with the requirement of NFPA or to the requirement of the local authority having jurisdiction.

INSTALLATION OF SPRINKLER ALARM

MODEL GEAIOUNTING TYPE - B

1. Locate and cut a hole through the building wall to accommodate a 20NB (3/4") pipe with coupling (galvanised pipe to be supplied by the installer). The required length of support pipe is equal to the thickness of the wall minus 30 millimetres. The pipe is to be threaded with the standard 20NB (3/4") pipe threading on the both ends to a length of 20 millimetres. Cut the drive shaft length, equal to the wall thickness plus 43 millimetres.
2. Insert one end of the drive shaft (19) into the square hole provided in the impeller (2) of the Sprinkler Alarm gong assembly.

One end of 20NB (3/4") support pipe is to be screwed to the coupling (26) provided with the assembly and the other end of the pipe is to be screwed to the housing (1) of the Sprinkler Alarm motor assembly as shown in the figure. Position this assembly against the building wall through a washer (24) with the support pipe extending through the wall.

3. Connect the alarm port of the Alarm Valve or Deluge Valve to the inlet of the Sprinkler Alarm assembly with 20NB (3/4") pipe, with proper support. A 20NB (3/4") strainer is to be provided as close as possible to the Sprinkler Alarm assembly.
4. Move to the other side of the wall, place protection cover (6) on to the pipe coupling (screwed to the pipe) and hold against the wall. Insert the bush (5, assembly with drive shaft adaptor) into the hole provided in the protection cover and thereby hand tighten the coupling extending through the wall. Make sure that the drive shaft is properly fitted in the square hole of impeller and drive shaft adaptor. This can be ensured by rotating the drive shaft adaptor. The drive shaft adaptor should rotate without any binding while tightening the bush. If any binding is noticed then unscrew the bush and refit. After ensuring that the drive shaft is properly placed in the square holes at both ends, wrench tight the bush.
5. Place the gong over the gong post with washers as shown in the cross-sectional drawing and hand tighten the dome nut, rotate the gong until the lettering is properly originated. Wrench tighten the dome nut.
6. Connect the 25NB (1") open drain pipe to the motor housing, taking due care that the drain discharge is running to a safe location and keep it free from obstruction.

NOTICE: The equipment presented in this bulletin is to be installed in accordance with the latest publication standards of NFPA or other similar organisations also with the provision of government codes or ordinances where applicable. The information provided by us are to the best of our knowledge and belief, and are general guidelines only. Site handling and installation control is beyond our reach. Hence we give no guarantee for result and take no liability for damages, loss or penalties whatsoever, resulting from our suggestion, information, recommendation or damages due to our product. Product development is a continuous programme of Rapidrop and hence the right to modify any specification without prior notice is reserved with the company.