

Pressure Reducing Valve

Models 90G 21 & 90A 21

UL Listed



- Globe or Angle Pattern
- Proven Reliable Design
- Available in Cast Bronze, Ductile Iron and Cast Steel
- Accurate Pressure Control
- In Line Service
- Grooved Ends (40 - 200 mm)

The 90G-21 (globe) and 90A-21 (angle) Pressure Reducing Valves are indispensable in any fire protection system. The diaphragm actuated design is proven highly reliable and easy to maintain. Available are globe or angle pattern with a full range of adjustments. A variety of material options are also available. Epoxy coating is strongly recommended for all fire system valves (excluding bronze valves). The 90G-21 and 90A-21 can be supplied with optional internal and external epoxy coating of the main valve wetted surfaces.

The RD 90G-21 (globe) and 90A-21 (angle) Pressure Reducing Valves automatically reduce a higher inlet pressure to a steady lower outlet pressure regardless of changing flow rate and/or varying inlet pressure. The valves pilot control system is very sensitive to slight downstream pressure fluctuations, and will automatically open or close to maintain the desired pressure setting. The downstream pressure can be set over a wide range by turning the adjustment screw on the CRD pilot control. The adjustment screw is protected by a screw-on cover, which can be sealed to discourage tampering.

Schematic Diagram

- | Item | Description |
|------|---------------------------|
| 1 | PRV (Globe or Angle) |
| 2 | Restriction Tube Fitting |
| 3 | Pressure Reducing Control |
| 4 | Flow Clean Strainer |

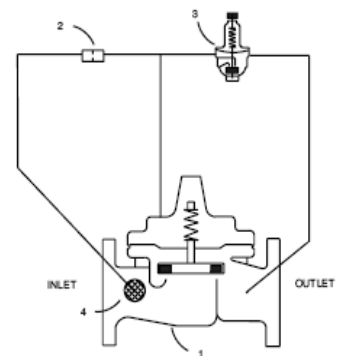

Typical Application

Underwriters Laboratories requires the installation of pressure gauges upstream and downstream of the Pressure Reducing Valve. Also, a relief valve of not less than 15 mm in size must be installed on the downstream side of the pressure control valve. Adequate drainage for the relief valve discharge must be provided.

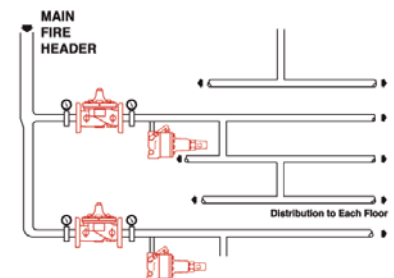

UL Listings

Size mm	Ductile Iron 150# F	Ductile Iron 300# S	Ductile Iron 300# F	Bronze 300# Threaded	Cast Steel 300# F	Globe Pattern Ductile Iron Grooved End	Angle Pattern Ductile Iron Grooved End
40	UL	UL	UL	UL		UL	
50	UL	UL	UL	UL	UL	UL	UL
65	UL		UL	UL	UL	UL	
80	UL	UL	UL	UL	UL	UL	UL
100	UL		UL		UL	UL	UL
150	UL		UL		UL	UL	
200	UL		UL			UL	
250							

Continued Overleaf
Page 1 of 2

Pressure Reducing Valve

Models 90G 21 & 90A 21

Dimensions

Value Size (mm)	40	50	65	80	100	150	200	250
A Threaded	184	238	279	318	-	-	-	-
AA 150 ANSI	216	238	279	305	381	508	645	756
AAA 300 ANSI	229	254	295	337	397	533	670	790
AAAA Grooved	216	228	279	318	381	508	645	-
B	28	38	43	65	81	109	135	235
BB Grooved	52	54	73	6.00	4.13	6.00	184	-
C (Max)	140	161	192	208	270	340	406	435
CC (Max) Grooved	104	127	175	165	223	281	369	-
D	71	84	102	116	146	200	254	300
DD Grooved	71	84	102	116	146	200	254	-
E Threaded	83	121	140	159	-	-	-	-
EE 150 ANSI	102	121	140	152	191	254	324	378
EEE 300 ANSI	108	127	149	162	200	267	349	395
EEEE Grooved	-	121	-	152	191	-	-	-
F Threaded	48	83	102	114	-	-	-	-
FF 150 ANSI	102	83	102	102	127	152	203	219
FFF 300 ANSI	108	89	109	111	135	165	216	236
FFFF Grooved	-	121	-	114	127	-	-	-
G (Max)	191	197	197	203	228	241	267	292
GG (Max)	206	203	-	207	236	267	292	-

UL Listed

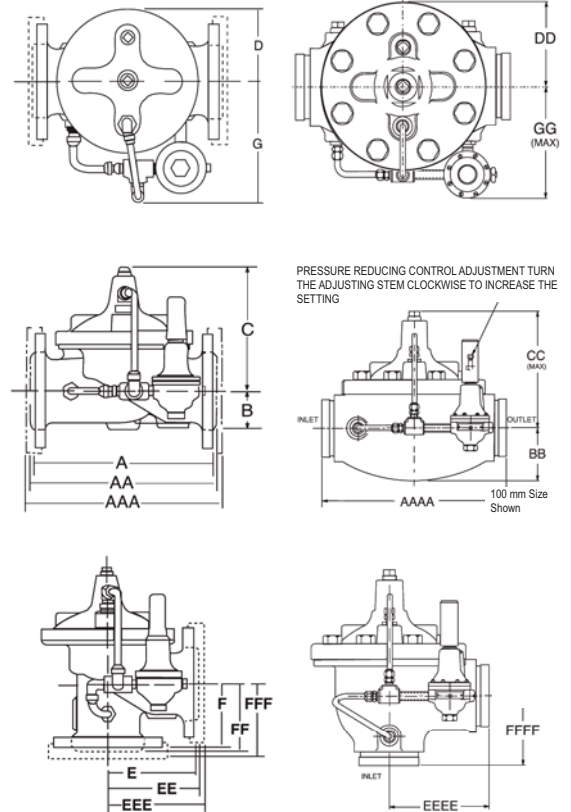

Specifications

Size: Class 175 lb. 40 mm - 200 mm (Globe)
50 mm - 150 mm (Angle)
Class 300 lb. 40 mm - 200 mm (Globe)
50 mm - 150 mm (Angle)

End Details: 150 ANSI B16.42 (Ductile Iron) (Bronze)
300# (Ductile Iron)
300# (Cast Steel).
300# (Ductile Grooved End).

Pressure Differential: 0.7 Bar Min.

Pressure Adjustment Range:
Class 175 lb. 2 – 11.3 Bar
Class 300 lb. 2 – 11.3 Bar

Temperature Range: Water to 82°C Max.

Flow Capacity Table

Valve Size mm	40	50	65	80	100	150	200	250
Max Flow Rate LPM (Litres per Min) of Water	606	992	1412	2180	3755	8521	14763	23280

Materials

Main valve body & cover: Ductile Iron - ASTM A536

Main valve internal trim: Bronze ASTM B61

Pilot control system –

Pilot control valve: Bronze ASTM B62 with Stainless Steel 303 internal trim
Copper tubing with brass fittings

Main valve and pilot valve

diaphragm and disc:
Buna-N® synthetic rubber

When Ordering Please Specify

1. Model Number 90-21
2. Size
3. Globe or Angle Pattern
4. Main Valve Body and Cover Material
5. Threaded, Flanged or Grooved
6. Pressure Class
7. Optional Epoxy Coating