

Pressure Relief Valve Model 50B -4KG-1

UL Listed / FM Approved

- Fast Opening to Maintain Steady Line Pressure
- Accommodates Wide Range of Flow Rates
- Closes Gradually for Surge-Free Operation
- Adjustable Pressure Settings, Not Affected by Pressure at Valve Discharge

The RD Model 50B-4KG-1 Globe / 2050B-4KG Angle Pressure Relief Valve is designed specifically to automatically relieve excess pressure in fire protection pumping systems. Pilot controlled, it maintains constant system pressure at the pump discharge within very close limits as demands change.



Typical Application

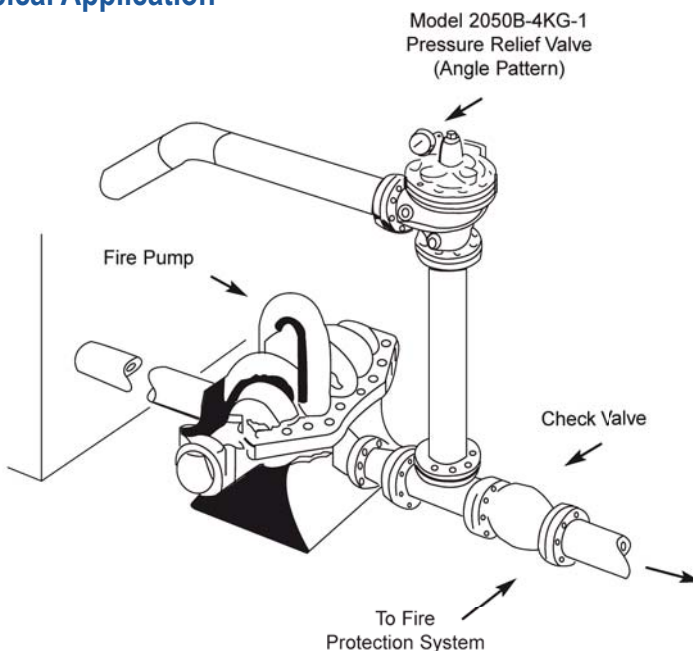

Operation Sequence

At pump start, the Relief Valve modulates to relieve excess pump capacity, maintaining positive system pressure at the pump discharge.

When fire demand slows or ceases, the Model 50B-4KG-1 opens, diverting entire pump output to discharge, allowing fire pump to be stopped without causing surging in the lines.

(Please note that if the Model 50B-4KG-1 is to be used on a continuous duty basis to maintain fire-system pressure, suitable back pressure must be provided on the valve to prevent cavitation damage. Please enquire for further details).

Valve Capacity Table

Valve Size mm	50	65	80	100	150	200	250	300
NFPA 20 Maximum Recommended LPM (Litres per Min)	787	1136	1893	3785	9464	18927	41640	60567

Continued Overleaf
Page 1 of 2

Pressure Relief Valve Model 50B -4KG-1

UL Listed / FM Approved

Dimensions

Value Size (mm)	50	65	80	100	150	200	250	300
Threaded Ends	238	279	318	-	-	-	-	-
A 150 Flanged	238	279	305	381	508	645	756	864
300 Flanged	254	295	337	397	533	670	790	902
300 x 150	-	-	327	389	522	657	773	883
B	84	102	116	146	200	254	300	356
C	305	311	318	330	363	414	457	522
D	38	43	65	81	109	135	235	273
Threaded Ends	121	140	159	-	-	-	-	-
E 150 Flanged	121	140	152	191	254	324	378	432
300 Flanged	127	149	162	200	267	337	395	451
Threaded Ends	83	102	114	-	-	-	-	-
F 150 Flanged	83	102	102	127	152	203	219	349
300 Flanged	89	109	111	135	165	216	236	368
G & H	152	170	197	200	216	248	337	362

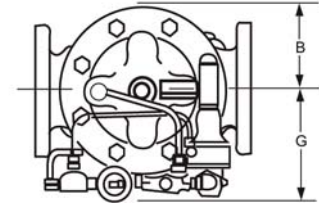

Model 50B-4KG-1 Globe

Model 2050B-4KG-1 Angle

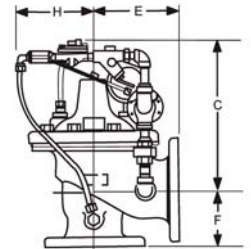
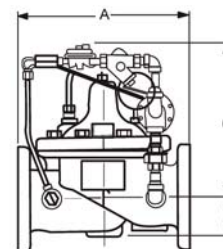

We recommend providing adequate space around valve for maintenance work

Specifications

Size: 50 mm - 300 mm (Globe)
50 mm - 300 mm (Angle)

End Details: 150 and 300 ANSI B16.42

Pressure Ratings: Class 150 – 12.0 Bar Max
Class 300 – 20.6 Bar Max
Water to 82°C Max

Materials

Main Valve Body & Cover: Ductile Iron - ASTM A536, Naval Bronze ASTM B61, Other Material Available
Standard Main Valve Trim: Bronze Seat, Teflon Coated, Stainless Steel Stem, Delrin Sleeved
Standard Pilot Control System: Cast Bronze with Stainless Steel trim

Adjustment Range

Available in the following relief pressure ranges: 1.4 - 13.8 Bar (150 Class) , 6.9 - 20.7 Bar (300 Class)

Optional

Protective epoxy resin coating of wetted surfaces of main valve cast iron components (UL listed HNFEX EX2855)

Sea Water Service Option

Globe: 50 mm - 250 mm Flanged. Angle: 50 mm - 250 mm Flanged. Please consult us for further details.

PURCHASE SPECIFICATIONS

The Fire Pump Pressure Relief Valve shall modulate to relieve excess pressure in a fire protection system. It shall maintain constant pressure in the system regardless of demand changes. It shall be pilot controlled and back pressure shall not affect its set point. It shall be actuated by line pressure through a pilot control system and open fast in order to maintain steady system pressure as system demand decreases. It shall close gradually to control surges and shall re-seat drip-tight within 5% of its pressure setting. The main valve shall be of the hydraulically-operated, pilot-controlled, diaphragm-type, globe or angle valve. It shall have a single, removable, teflon-coated seat, a grooved stem guided at both ends, and a resilient disc with a rectangular cross section, being contained on 3 1/2 sides. No external packing glands shall be permitted and the diaphragm shall not be used as a seating surface. The pilot control shall be a direct-acting, adjustable, spring-loaded, diaphragm-type valve designed for modulating service to permit flow when controlling pressure exceeds spring setting. This valve shall be UL Listed and Factory Mutual approved. It shall be the Model 50B-4KG-1 (globe) or Model 2050B-4KG-1 (angle) Pressure Relief Valve.

*Special Note:

The Model 50B-4KG-1 Pressure Relief Valve is available with 300# ANSI inlet flange and 150# ANSI outlet flange. This valve is used on higher pressure systems where 300# flange connections are required, and allows for adapting of a discharge cone (generally supplied with 150# flange) to accommodate "atmospheric break" at relief valve discharge. This relief valve, with 300# / 150# flanges is available on special order, and is UNDERWRITERS LABORATORIES LISTED AND FACTORY MUTUAL APPROVED.