

## Non Rising Stem Resilient Wedge Gate Valve Model 104 FF

UL Listed /FM Approved

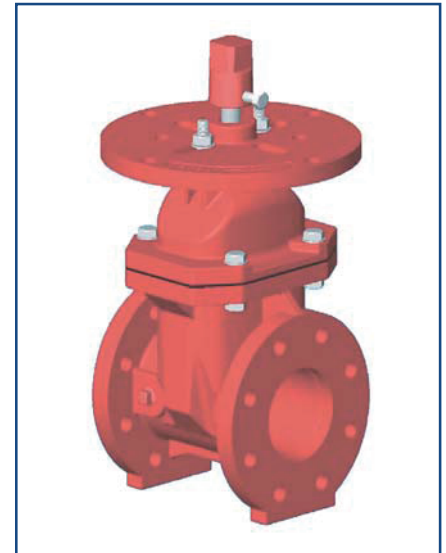
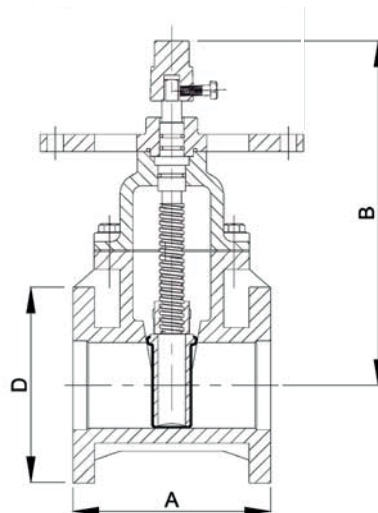
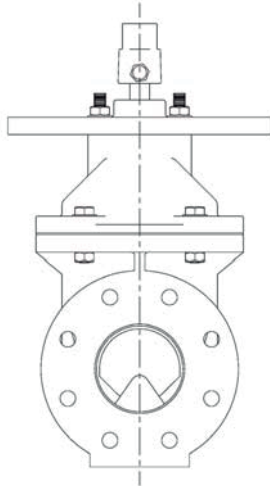

### Valve Standard

Conforms to AWWA C509

### Pressure & Rating

Non-Shock Cold Working Pressure, 300 PSI/20.7 Bar (Sizes 2 1/2"-10") 250 PSI/17.2 Bar (Sixe 12")

Coating - Electrostatically applied fusion - bonded epoxy 0.2-0.5 mm. inside and outside.  
Meets and exceeds AWWA C550. Maximum operating temperature 160 °F / 71 °C

Drilled and Tapped Plugged at Boss Location A: 1/2" - valve sizes 2 1/2" - 4"  
3/4" - valve sizes 6" - 8"  
1" - valve sizes 10" -12"

Size	65 mm	80 mm	100 mm	150 mm	200 mm	250 mm	300 mm
A	190	203	229	267	292	330	356
B	293	322	352	445	528	617	705
D	178	191	229	279	343	406	483
Turns to Open	8.8	10.6	13.0	15.6	17.3	21.4	25.3
Weight (Kg)	16	20	32	55	89	134	194

Freezing weather precaution - subsequent to testing a piping system, valves should be in an open position to allow complete drainage.

Option of PN-16, ANSI-125 and ANSI150 available  
Post indicator plates standard on 4" to 12" valves only

Continued overleaf

Page 1 of 2

### Rapidrop Global

Rutland Business Park, Newark Road, Peterborough, PE1 5WA, United Kingdom

Tel: +44 (0) 1733 847 510 Fax: +44 (0) 1733 553 958

e-mail: [rapidrop@rapidrop.com](mailto:rapidrop@rapidrop.com) web: [www.rapidrop.com](http://www.rapidrop.com)

# Non Rising Stem Resilient Wedge Gate Valve Model 104 FF

**UL Listed / FM Approved**

## Material Specifications

Valve Body	Ductile Iron ASTM A 536
Resilient Wedge	Ductile Iron ASTM A 536/EPDM ASTM D 2000
Wedge Nut	Bronze ASTM B 584 UNS C83600
Stem	Bronze ASTM B 150 UNS C61400
Bonnet Gasket	EPDM ASTM D 2000
Bonnet screw	Alloy steel ASTM A 574M Zinc plated
Bonnet	Ductile iron ASTM A 536
Stern Primary O-ring	EPDM ASTM D2000
Stern Thrust Washer (upper)	Bronze ASTM B 584 UNS C83600
Stern Thrust Washer (lower)	Stainless Steel ASTM A 276 UNS S41000
Gland Seal O-ring	EPDM ASTM D 2000
Stern Sealing Brushing	Bronze ASTM B 584 UNS C83600
Stern Secondary O-ring (2)	EPDM ASTM D 2000
Gland Flange	Ductile Iron ASTM A 536
Stem Ring Wiper	EPDM ASTM D 2000
Square Operating Nut	Cast Iron ASTM A 126-B
Operating Nut Washer	Carbon Steel Zinc Plated
Operating Nut Screw	Alloy Steel ASTM A 574M Zinc Plated
Gland Flange Screw	Alloy Steel ASTM A 574M Zinc Plated
Indicator Flange Screw	Alloy Steel ASTM A 574M Zinc Plated
Indicator Post Flange	Ductile Iron ASTM A 536