



SPECIFICATION SHEET

302-0312



ANSI TYPE R CLASS 2 WOMAN'S CONTOURED VEST WITH SOLID FRONT, MESH BACK AND ADJUSTABLE WAIST

- Designed and sized specifically for women
- Solid front and mesh back for breathability
- 2" reflective tape
- Silver reflective piping
- Drawstring adjustable waist
- Zipper closure
- 1 lower inner cell pocket
- 2 outer zippered waist pockets

APPLICATIONS

- Construction
- Municipalities
- Shipyards
- Anywhere hi-visibility apparel is necessary

CARE INSTRUCTIONS

Recommend washing in tempered water not exceeding 104°F or 40°C. Wash in a 5-10 minute cycle time or hand wash. Rinse in cold water. Tumble dry at temperature not exceeding 104°F or 40°C, do not wring. Do not wash in biological powder, wash as synthetics. Maximum of 30 wash cycles.

TECHNICAL DATA

MATERIAL	100% Polyester
CONSTRUCTION	Main Fabric: 120g/m ² polyester mesh Accessories: 2" nylon reflective tape
COLOR	■ Hi-Vis Lime Yellow
SIZES	S - 2XL
PACKAGING	1 per bag, 5 per inner pack, 50 per case
CASE DIMENSIONS	20.9" x 16.5" x 14.2" / 53cm x 42cm x 36cm
CASE WEIGHT	28.7 lbs / 13 kg
COO	China

BARCODES

ITEM	BAG	INNER PACK	CASE
■ 302-0312-LY/S	616314260025	01616314260024	02616314260023
■ 302-0312-LY/M	616314260032	01616314260031	02616314260030
■ 302-0312-LY/L	616314260018	01616314260017	02616314260016
■ 302-0312-LY/XL	616314260049	01616314260048	02616314260047
■ 302-0312-LY/2X	616314260056	01616314260055	02616314260054



DIMENSIONS (in/cm)

	S	M	L	XL	2X
A	42.5 / 108	44.1 / 112	45.7 / 116	47 / 120	48.8 / 124
B	29.5 / 75	30.3 / 77	31.1 / 79	31.9 / 81	32.7 / 83
C	10.2 / 26	10.6 / 27	11 / 28	11.5 / 29	11.8 / 30

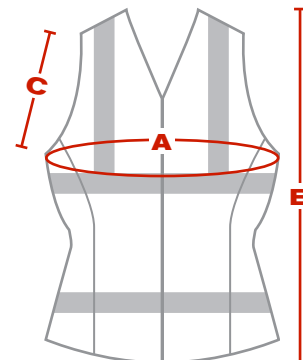

PROTECTIVE INDUSTRIAL PRODUCTS, INC. | BRINGING THE BEST OF THE WORLD TO YOU®

AMERICAS: (800) 262-5755 • (518) 861-0133 | EUROPE: +34-96182-41-48 | AMEA: (ASIA, MIDDLE EAST, AFRICA) 852-2475-9228 | www.pipglobal.com

This document and the information contained herein is the property of Protective Industrial Products, Inc. (PIP) and may not be used or reproduced without permission. Product users should conduct all appropriate testing or other evaluations to determine the suitability of PIP products for a particular purpose or use within a particular environment. PIP DISCLAIMS ALL WARRANTIES OTHER THAN AS EXPRESSLY PROVIDED.