

**MCD**

**1.1** *ALU30*  
Front-roll



# ALU30 FRONT ROLL

## DESCRIPTION

The ALU 30 roll-up door is made to measure with double-walled installable slats of extruded aluminium 30mm height.

The doors can be used to close compartments or as a loading, access door in all types of vehicles as a replacement for conventional opening doors.

It is delivered in the form of separate parts ready to be installed.

- 1 assembled door
- 1 pair of aluminium tracks ready to be fixed into position.
- 1 tensed roller
- 1 bag of accessories

The standard finish is in RAL 7035 satin finish powder coated grey, but can also be delivered in RAL 9010, anodized, mill or in another choice of RAL.

Different kinds of closing systems and options compatible with ALU30 are available in the following chapters 3 and 4 of this documentation.



Usage dimensions	
Maximum height	2200 mm
Maximum width	2500 mm
Minimum width	550 mm
Maximum area	4 m <sup>2</sup>
Door weight for 1 m <sup>2</sup>	12 kg

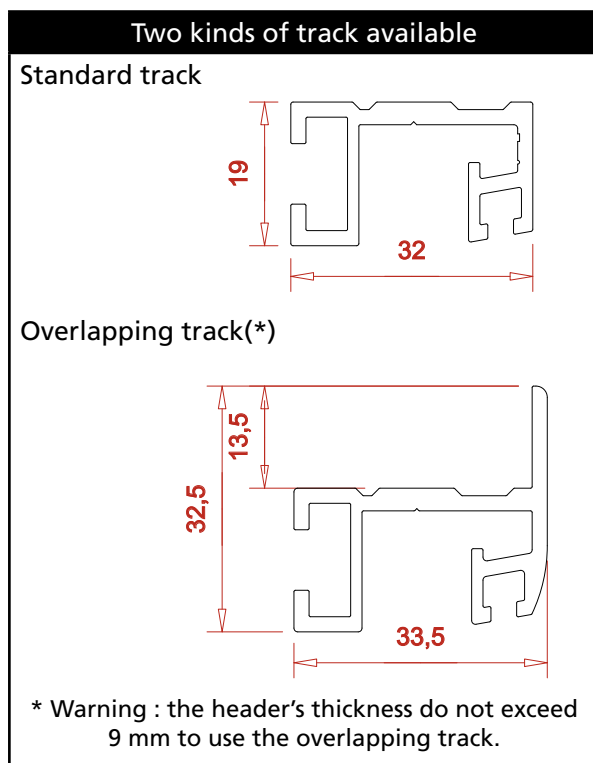

**Waterproof with 4 seals**  
(Detail page 4.7.1)

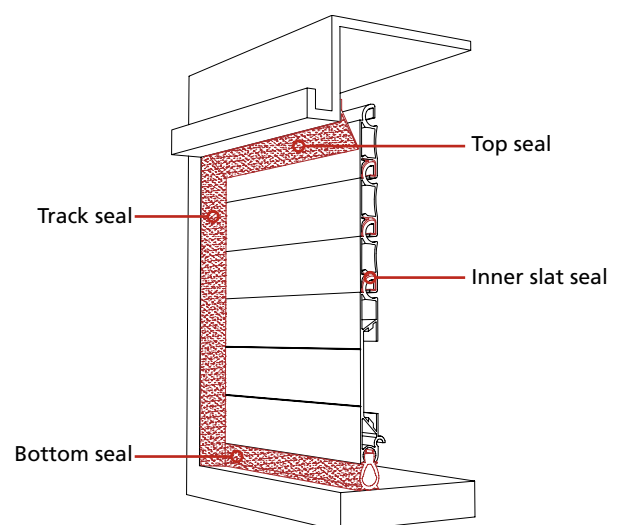

# SETTING UP

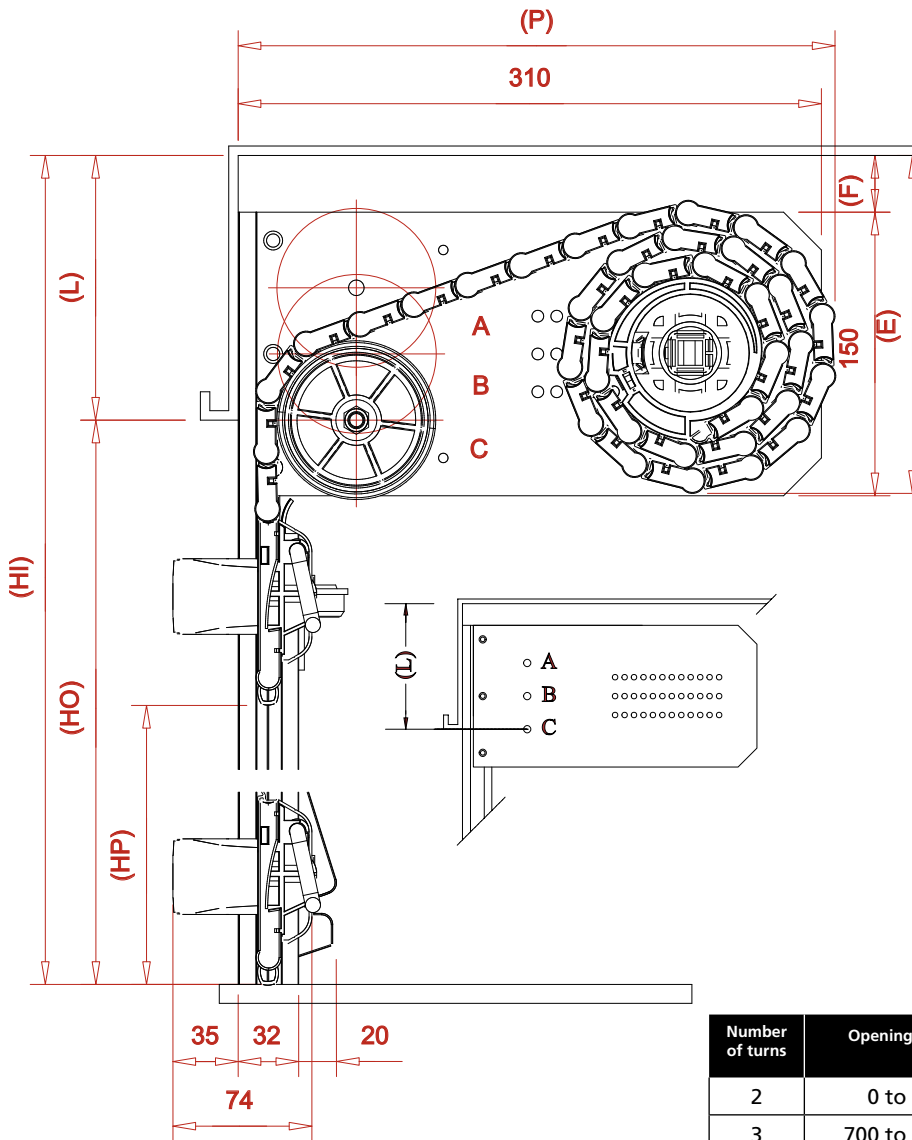

	Description
HI	Interior Height
HO	Opening Height
HP	Passing Height
L	Header
P	Depth
LP	Passing Width
LER	Total Width

### Formulae to remember:

$$HI = HO + L$$

$$HP = HO - 100 \text{ mm}$$

L = to be calculated according to HO and with the help of the board below. Take care: various possibilities according to the position A, B or C of the wheel. For optimum functioning of the door the position selected should be C.  $LP = LER - 50\text{mm}$

Number of turns	Opening HO	L mini			P	E	F
		A	B	C			
2	0 to 700	80	110	140	240	160	20
3	700 to 1150	80	110	140	260	180	20
4	1150 to 1700	100	120	140	290	200	30
5	1700 to 2300	120	140	160	310	220	40

## Compatible closing systems with ALU30

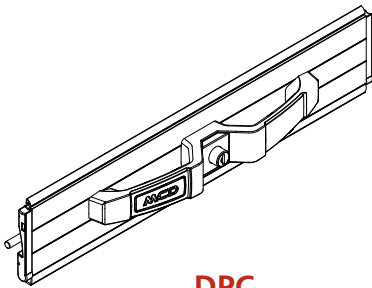

**DPC**  
Double handle with key  
(see page 3.1.1)

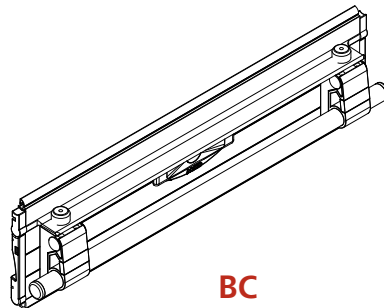

**BC**  
Bar lift handle with key  
(see page 3.2.1)

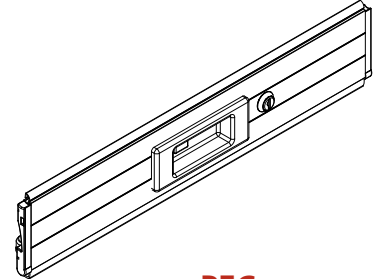

**PEC**  
Built-in handle with key  
(see page 3.3.1)

# EXPLODED VIEW ALU30 FRONT ROLL

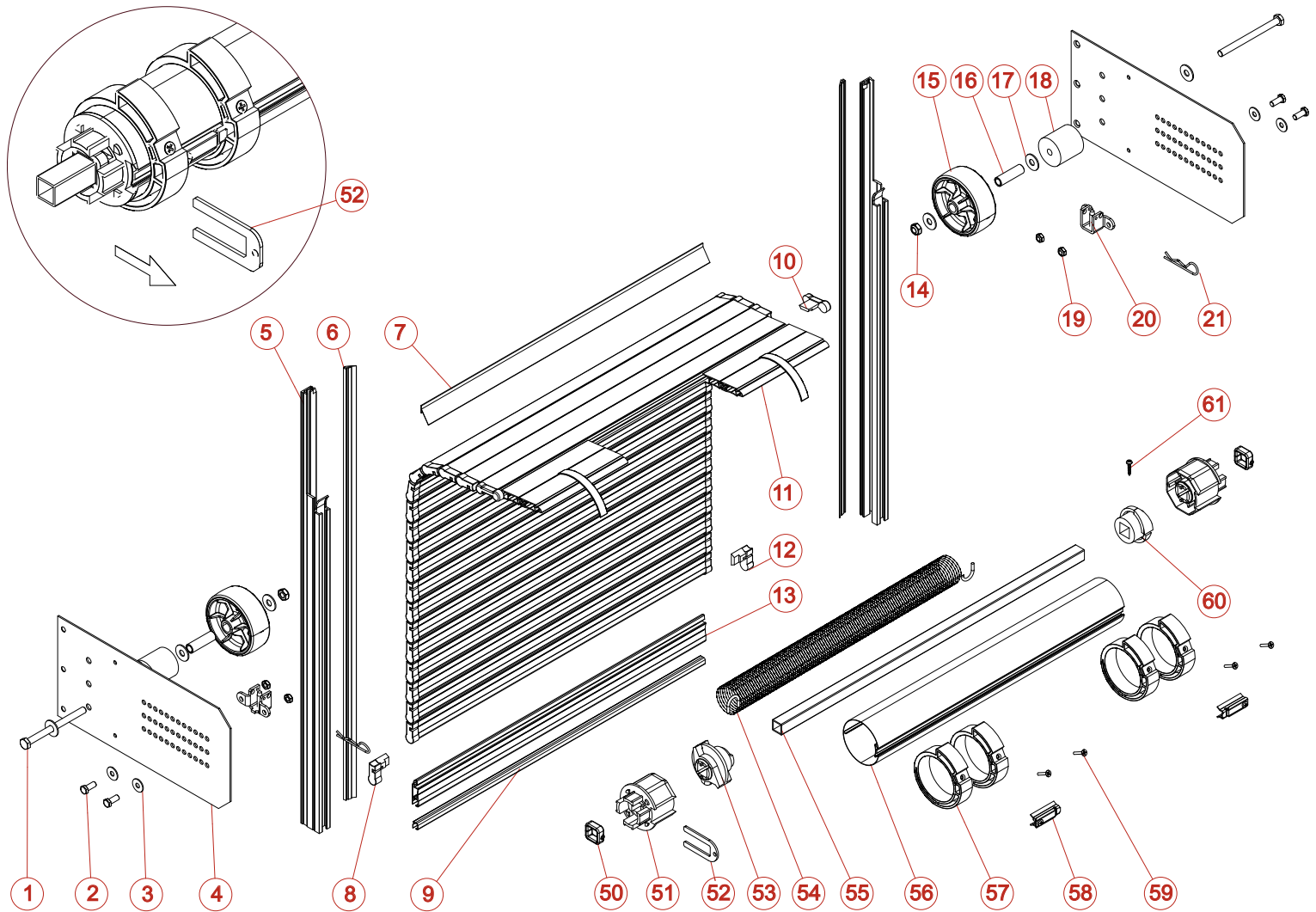

REP	CODE	DESCRIPTION
1	3300	STAINLESS SCREW TH 8 X 100
2	3303	STAINLESS SCREW TH 6 X 16
3	3304	STAINLESS RING L 6
4	3115	SIDE PANEL FOR ALU30
5	1300	STANDARD TRACK
6	2023	TRACK SEAL (M)
7	2030	TOP SEAL (M)
8	4002	SLAT LEFT CAP
9	2004	INNER SLAT SEAL (M)
10	4004	SLAT SPECIAL CAP
11	8114	LOOPS GUIDE
12	4003	SLAT RIGHT CAP
13	1001	ABE SLAT 30 (M)
14	3302	STAINLESS LOCK NUT M 8
15	4110	WHELL 80 DIA
16	3109	STEEL SPACER
17	3301	STAINLESS RING L 8

REP	CODE	DESCRIPTION
18	4107	PLASTIC SPACER
19	3305	STAINLESS LOCK NUT M 6
20	3139	ROLLER SUPPORT
21	3371	STAINLESS BETA PIN 2,5
50	3163	STIRRUP
51	4100	TERMINAL CAP FOR TUBE 62
52	3108	BLOCKING FORK
53	4102	MOBILE ROLLER SPRING ATTACHMENT FOR TUBE 62
54		SPRING
55	3100	STEEL TUBE 16 X 16 X 1.5 (M)
56	3102	ROUND TUBE 62 (M)
57	4108	ROLLER RING 62
58	3106	ROLLER CLIP DIAM 62
59	3327	SCREW TF POZIDRIV Z 4 X 18
60	4104	FIXED ROLLER SPRING ATTACHMENT FOR TUBE 62
61	3309	STAINLESS SCREW TCL POZIDRIV 3.9 X 19

Elements list and exploded view of closing systems are introduced in the chapter 3 of this documentation.