



**LANCIER**  
Hydraulik

GmbH & Co. KG

[www.lancier-hydraulik.de](http://www.lancier-hydraulik.de)

# *Rescue Rams*

# *performance Line*

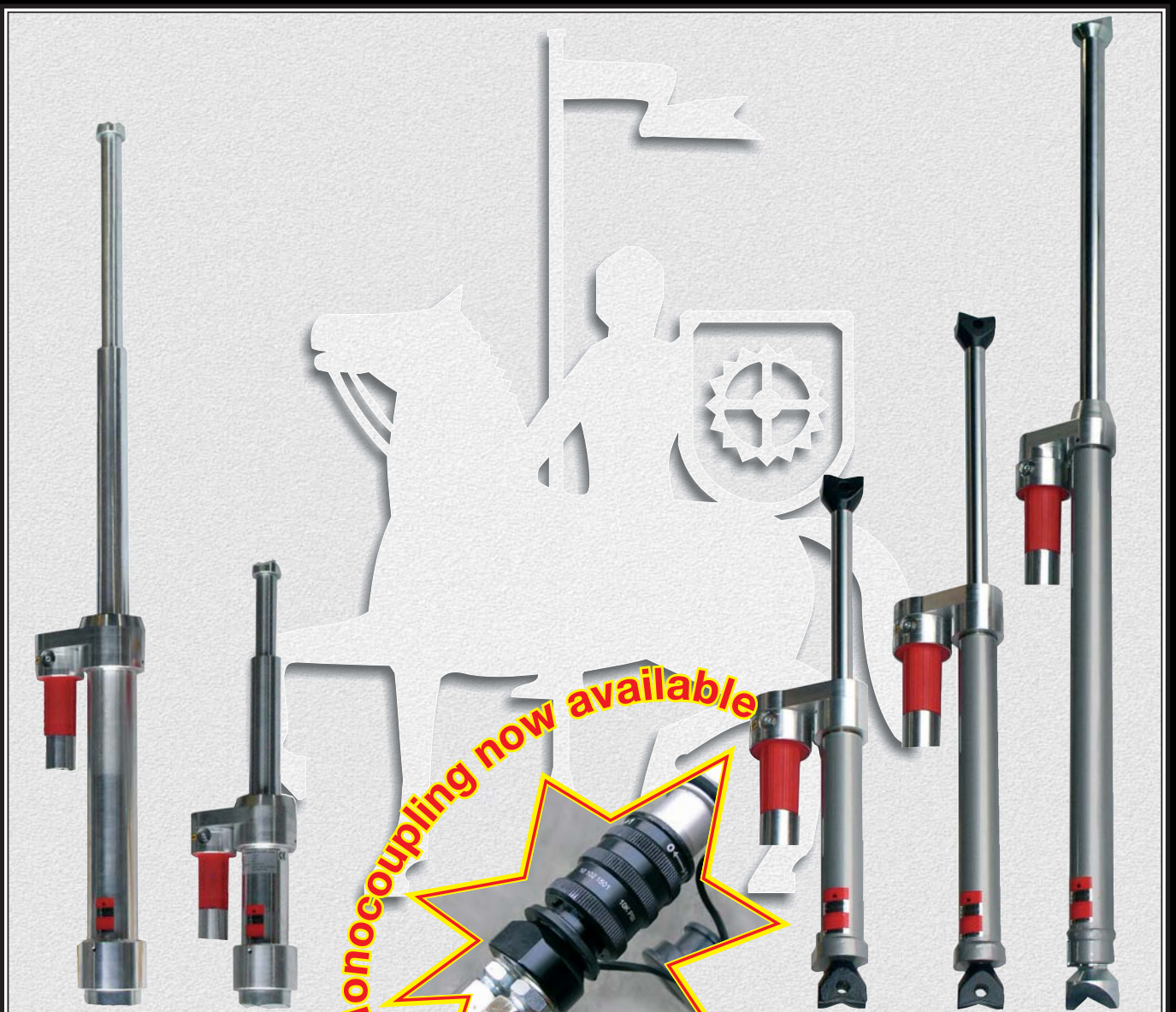

***... when it gets tough !***

# Rescue rams



## Type LH-RT-11560

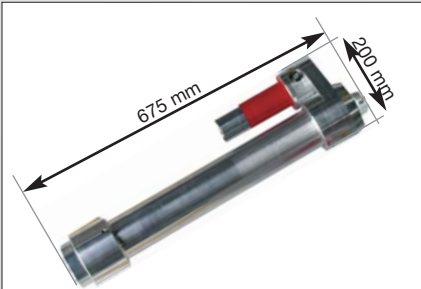

Spreading force max.	224/71 kN
Length extended	1560 mm
Length retracted	675 mm
Width	110 mm
Height	200 mm
Weight	20.1 kg
<b>Order-No.*</b>	<b>76340</b>

## Type LH-RT-1835

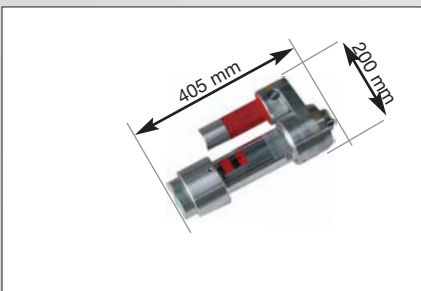

Spreading force max.	224/71 kN
Length extended	835 mm
Length retracted	405 mm
Width	110 mm
Height	200 mm
Weight	13.8 kg
<b>Order-No.*</b>	<b>76330</b>

**Performance factor 2.6**  
**Power/Weight ratio 11.4 kN/kg**

**Power/Weight ratio 7.8 kN/kg**  
**Performance factor 3.6**

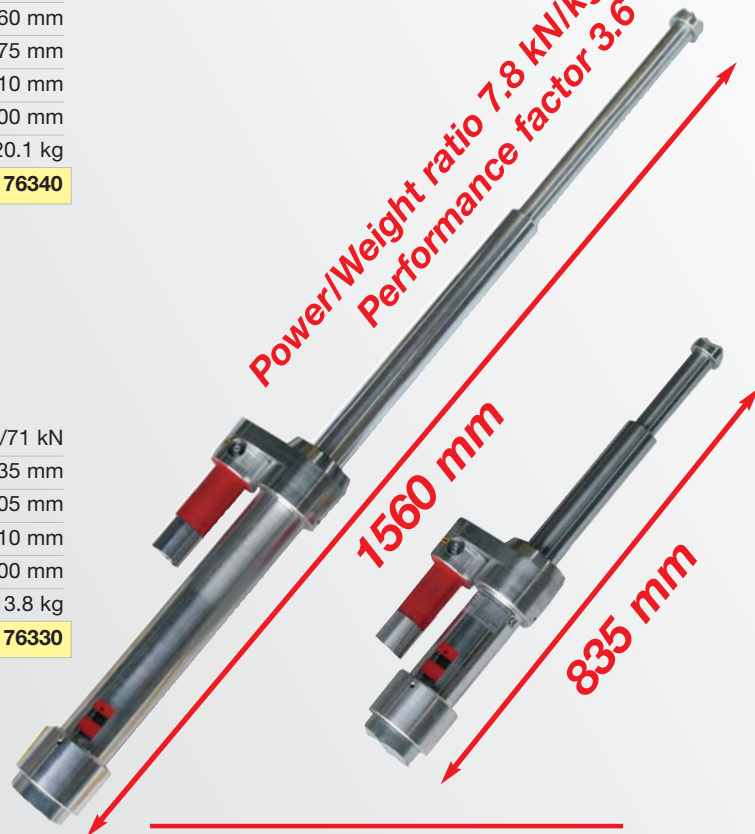

\* All specifications refer to operating pressure of 720 bar, without hoses.

Subject to alterations, errors excepted.



## Type LH-R-11600



Spreading force max.	115 kN
Length extended	1600 mm
Length retracted	915 mm
Width	85 mm
Height	180 mm
Weight	21.0 kg
<b>Order-No.*</b>	<b>76320</b>

**Performance factor 3.8**  
**Power/Weight ratio 5.5 kN/kg**

## Type LH-R-11100

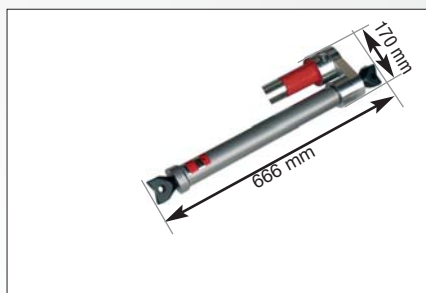

Spreading force max.	90 kN
Pulling force max.	33 kN
Length extended	1100 mm
Length retracted	666 mm
Width	85 mm
Height	170 mm
Weight	12.8 kg
<b>Order-No.*</b>	<b>76310</b>

**Performance factor 3.1**  
**Power/Weight ratio 7.0 kN/kg**

## Type LH-R-1800

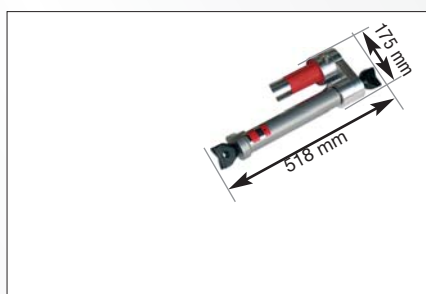

Spreading force max.	90 kN
Pulling force max.	33 kN
Length extended	800 mm
Length retracted	518 mm
Width	85 mm
Height	175 mm
Weight	10.4 kg
<b>Order-No.*</b>	<b>76300</b>

**Performance factor 2.4**  
**Power/Weight ratio 8.6 kN/kg**

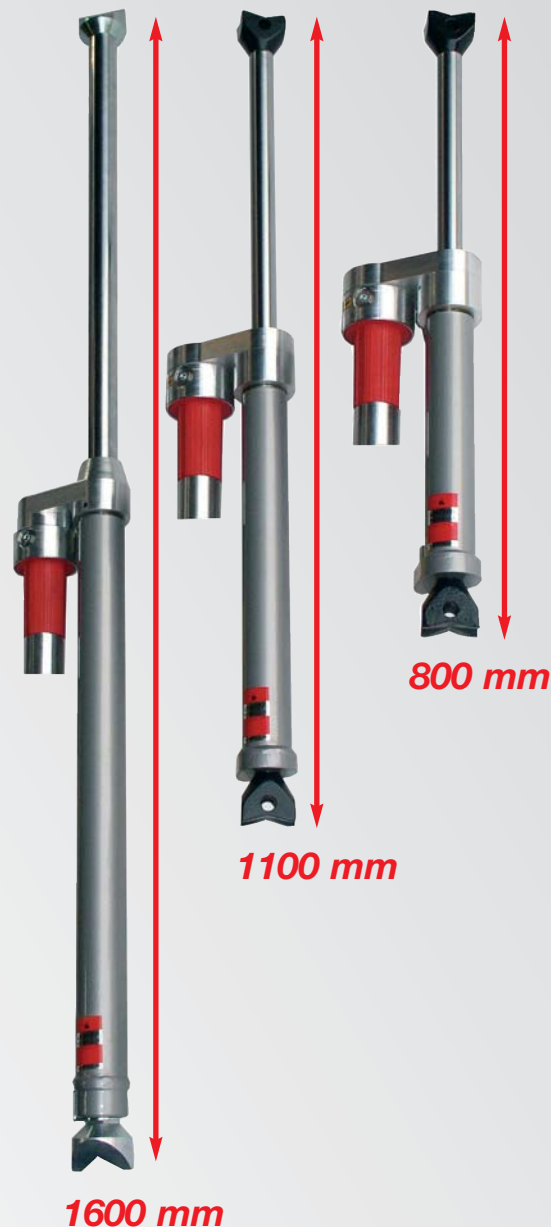

### Special features

- Opening widths up to 1600 mm**
- Spreading force up to 224 kN**
- Operating pressure 630 to 720 bar
- High pressure pigtails, 500 mm long, equipped with kink protection
- Automatic locking, flat face quick connect couplings
- Optional with **Monocoupling**
- Twist grip safety control with integrated over pressurization protection
- Harmonized size, matches to the spreading width of LANCIER Hydraulik spreaders
- Extension of the pushing distance in connection with the LANCIER ram support
- Exchangeable tips; partly prepared for the direct connection of pulling chains
- Optimum power/weight ratio



# Accessories

## Pulling chains



LANCIER Hydraulik pulling chains can be attached directly to the tips of the rescue rams LH-R-1800 and LH-R-11100 without tip exchange.

The required length is easily adjusted by inserting the chain links into the attached collet.

Pulling chains are delivered as a set consisting of 2 chains and 2 collets.

For LH-R-1800 and LH-R-11100

**Order-No. 71373**



## Base plates and wedge heads



Base plates and wedge heads extend the operating ranges of LANCIER Hydraulik rescue rams.

For LH-R-11100 and LH-R-1800

**Order-No. Base plate 49934**

For LH-R-11600

**Order-No. Base plate 50156**

**Order-No. Wedge head 25219**



## Ram support base



The galvanized ram support base from LANCIER Hydraulik is a stable and secure base for rescue rams.

3 notches allow for a longer stroke of the rescue rams. The ram support base can be applied horizontally and vertically.

**Order-No. 66180**



## Monocoupling



All of LANCIER Hydraulik's rescue tools can be equipped with monocouplings.

- Secure coupling of both lines in one action
- Coupling under pending pressure
- 360° freely rotatable: reduces stress to high pressure hoses

**Order-No. Nipple 73994**

**Order-No. Socket 73993**

Your qualified LANCIER Hydraulik partner

Subject to alterations, errors excepted.