

**INSTRUCTION MANUAL**

---

**AUTO-PUMP<sup>®</sup>**  
**120 VAC**

**AIR COMPRESSOR SYSTEM**



**MODEL # :091-9B-4**

**INPUT :120 volt, 50/60 Hz, 3.3 AMPS**  
**OUTPUT: 100 PSI MAXIMUM**

File: 091-9B-4\_revA\_GEN4  
Rev: A  
Revised By :THN  
Date: 10-19-21

**2 YEAR WARRANTY**

---

170 Cherry Avenue  
West Sayville, NY 11796  
www.kussmaul.com

**KE KUSSMAUL<sup>™</sup>**  
**ELECTRONICS**  
*ENERGIZED AND READY, WHEN SECONDS COUNT*

Ph: 800-346-0857  
Fax: 631-567-5826  
sales@kussmaul.com

## **INTRODUCTION**

---

The 091-9B-4 Auto-Pump Air Compressor system is a 120 volt 50/60 Hz capacitor start A.C. motor operating a single cylinder air compressor designed specifically for installation on vehicles with air brakes. During long idle periods of the vehicle when even the slightest seepage can cause an air brake system pressure to drop below the brake lockup pressure, the Auto Pump automatically starts to help maintain operating pressure.

The Auto Pump motor is directly coupled to the compressor section eliminating all belts and pulleys assuring long life and reliable operation. A heavy duty pressure switch is adjusted to start the compressor when the system pressure drops below 75 psi and stops the compressor when 95 psi is attained. The start up pressure is field adjustable - the pressure differential between start up and stopping is fixed.

A moisture trap is mounted on the Auto Pump. This helps capture condensate which results from compressing the air.

**\*Moisture trap should be checked periodically and drained as necessary.**

Please read and follow the installation instructions carefully. The Auto Pump requires no routine maintenance. A careful installation will assure years of trouble free operation.

### **NOTE**

**THIS PUMP REQUIRES A MINIMUM OF 110 VOLTS. FOR OPERATION AT LOWER VOLTAGES THE PUMP WILL NOT START**

# **CAUTION**

**NO CONDENSATE OR  
WATER MUST BE ALLOWED  
TO ENTER OR ACCUMULATE  
IN THE OUTPUT  
OF THE AUTO PUMP.  
ROUTE OUTPUT PRESSURE  
LINE DOWNWARD FROM  
AUTO PUMP TO PERMIT  
MOISTURE TO DRAIN AWAY.**

**WATER IN THE PUMP  
OUTLET WILL INDUCE**

## **FAILURE!**

**WATER DAMAGE WILL  
VOID WARRANTY**

# VEHICLE TUBING INSTALLATION

1. Mount all components in a suitable location, preferably in a high area above the air system. Do not mount in engine compartment or near any source of heat or dirt. The system may be connected to any point in the vehicle's air system.
2. Mount air compressor in the position as shown being certain that the compressor is above air pressure tank.
3. **CAUTION:** No condensate or water must be allowed to enter or accumulate in the output of the Auto Pump. Route output pressure line downward from Auto Pump to permit moisture to drain away. **Water in the pump outlet will induce failure.**
4. All connections for air lines are 1/4" NPT. Use Teflon tape, or equivalent on all connections to insure no leakage of air.
5. The recommended installation of the Auto Pump air compressor system is shown below.
6. Note that an external check valve is located between the compressor and the pressure switch. No additional check valve is required.
7. Mount the air compressor. Connect a suitable piece of flexible tubing from the outlet port of compressor to the air tank. (Tubing and connectors are not supplied)
8. An optional Mounting Plate is available to help reduce vibration and noise from Auto Pump and to simplify pump mounting.

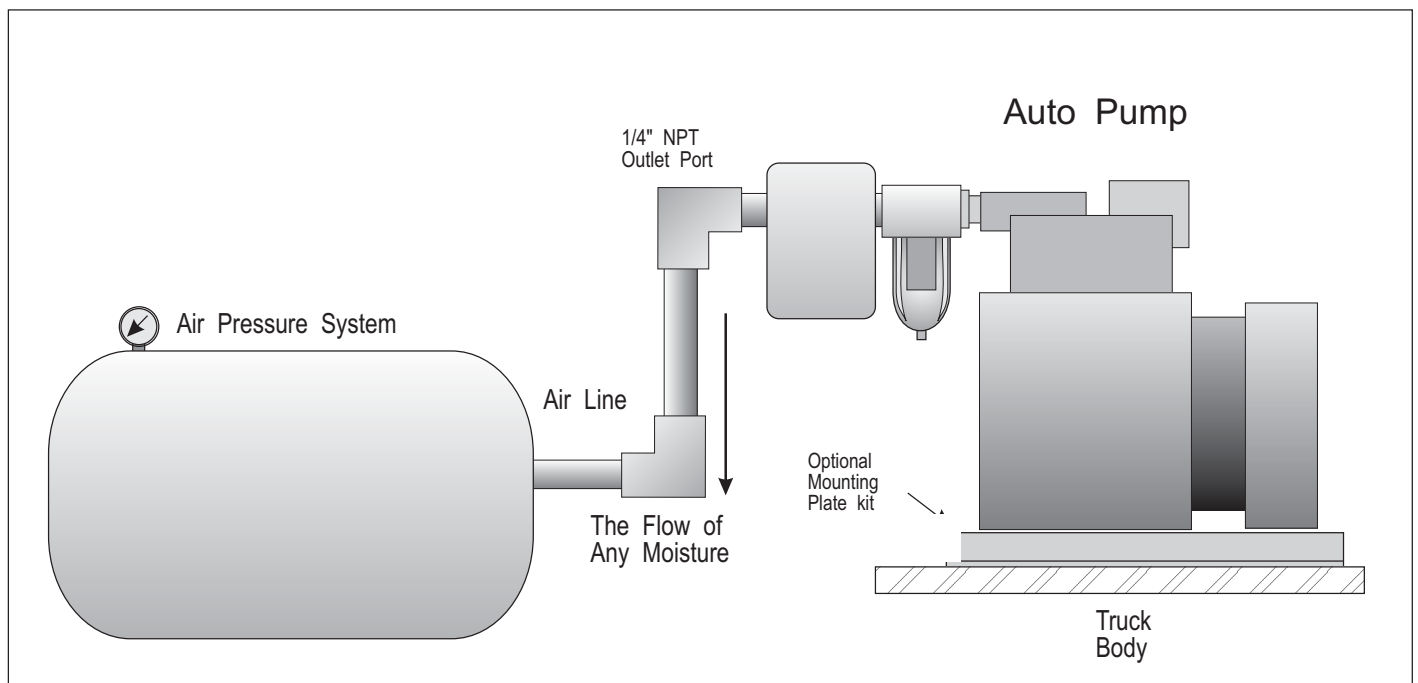

# VEHICLE WIRING INSTALLATION

1. The Auto Pump is supplied with a 120 volt A.C. line cord and is ready to operate. The line cord may be plugged into an available outlet or the cord may be cut and permanently wired to the 120 volt A.C. system in the vehicle.
2. The compressor is calibrated to cut-in at 75 PSI and cut-out at 95 PSI. For higher cut-in and cut-out, turn the range nut clockwise. To lower cut-in turn range nut counterclockwise. Do not exceed 100 PSI cut out.

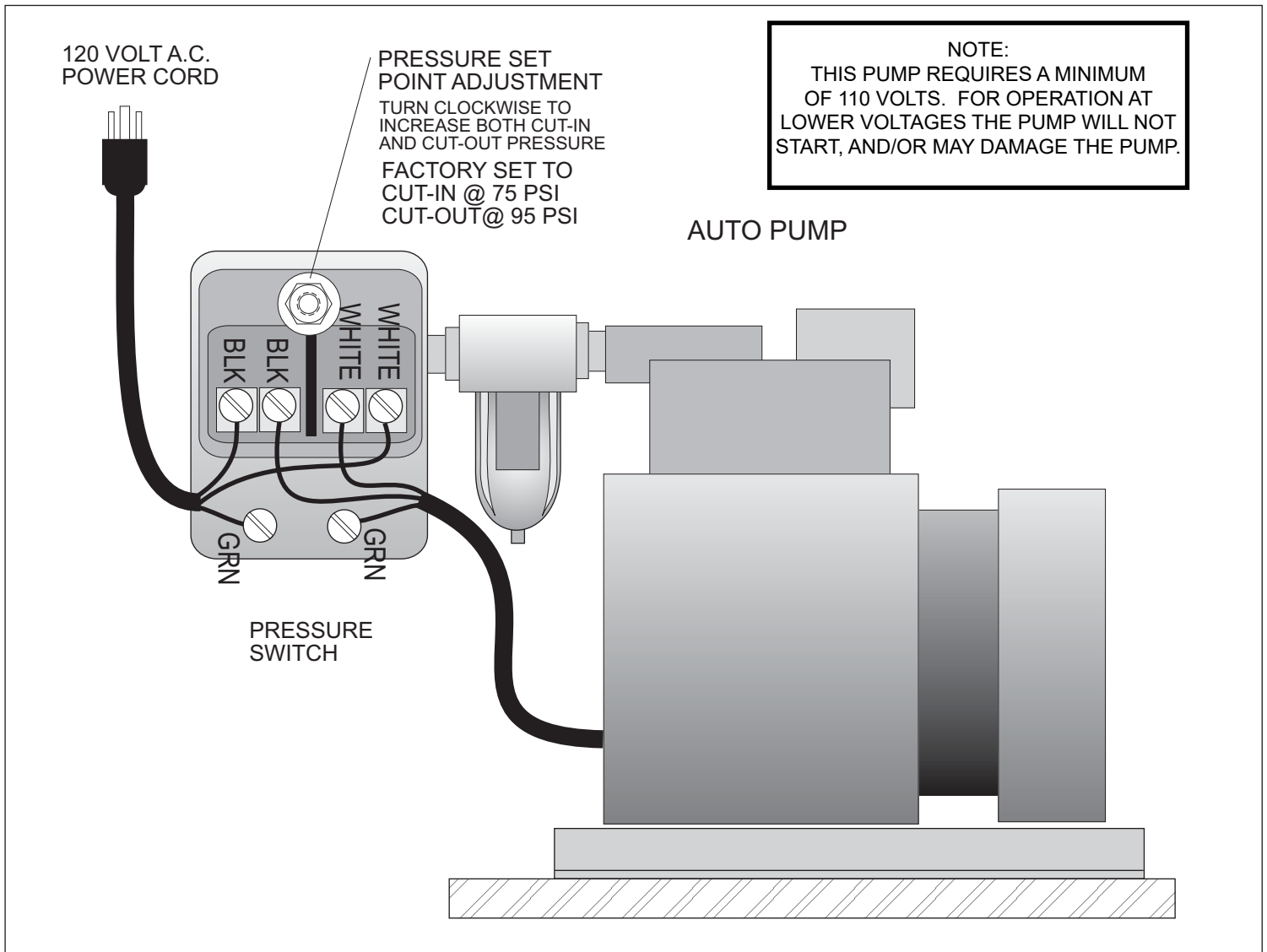

**COMPRESSOR OUTPUT IS 100 PSI MAXIMUM.  
DO NOT EXCEED 100 PSI OR YOU WILL VOID**

**WARRANTY.**

# **SPECIFICATION & OUTLINE AUTO PUMP**

Input : 120 volts A.C., 50/60 Hz, 3.3 amps

Weight: 13 lbs

Motor Horsepower: 1/8 HP

Motor Type: Split capacitor A.C.

Compressor Output: 100 PSI Maximum.

Pressure Switch: Set to 75 PSI Cut-in, 95 PSI Cut-out (+/- 5 PSI )

Switch Differential: 20 PSI Nominal

Outlet Connection: 1/4 NPT, Female

Operating Temperature: 0°C to 43°C

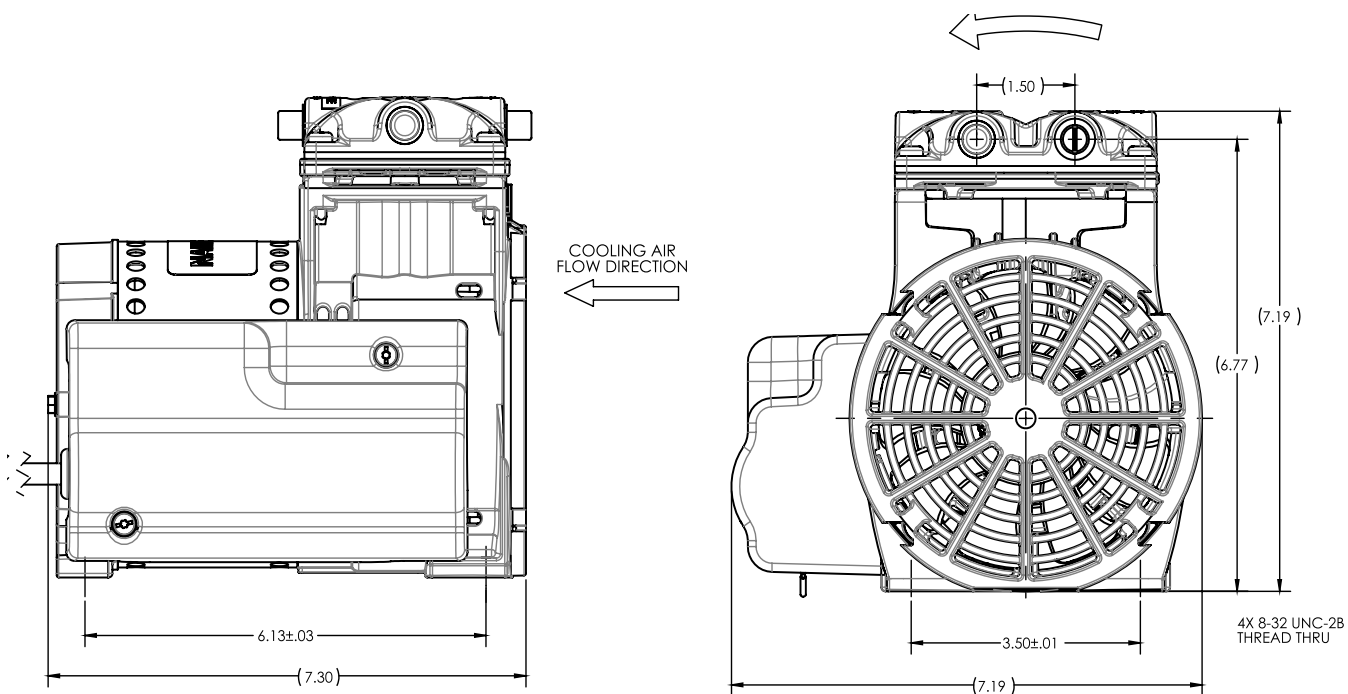

170 Cherry Avenue  
West Sayville, NY 11796  
www.kusssmaul.com



Ph: 800-346-0857  
Fax: 631-567-5826  
sales@kusssmaul.com

# TEMPLATE AUTO PUMP

---

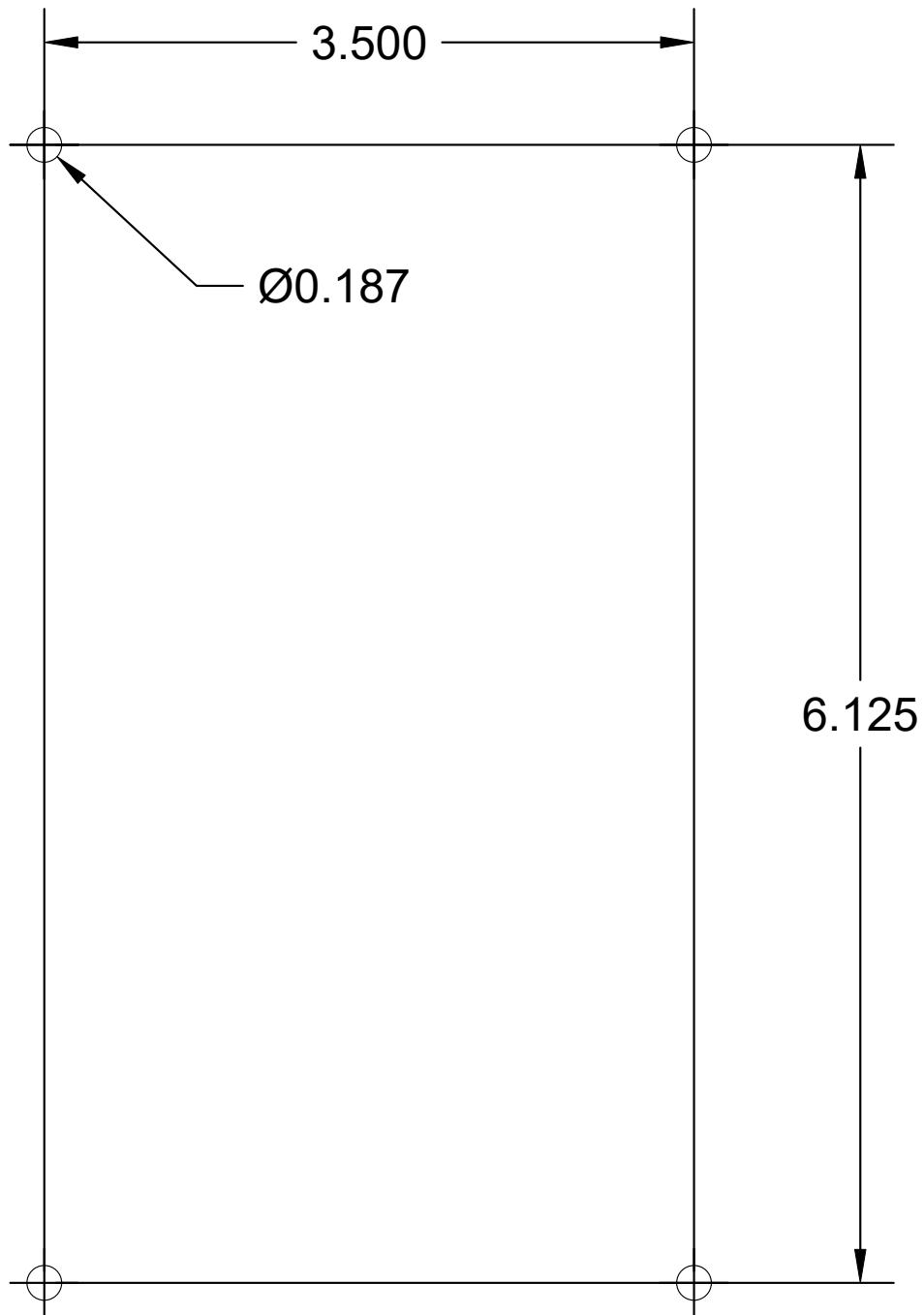

Note: Verify measurements before using as a template.  
Must set print settings to "Actual Size".

## ACCESSORIES

---

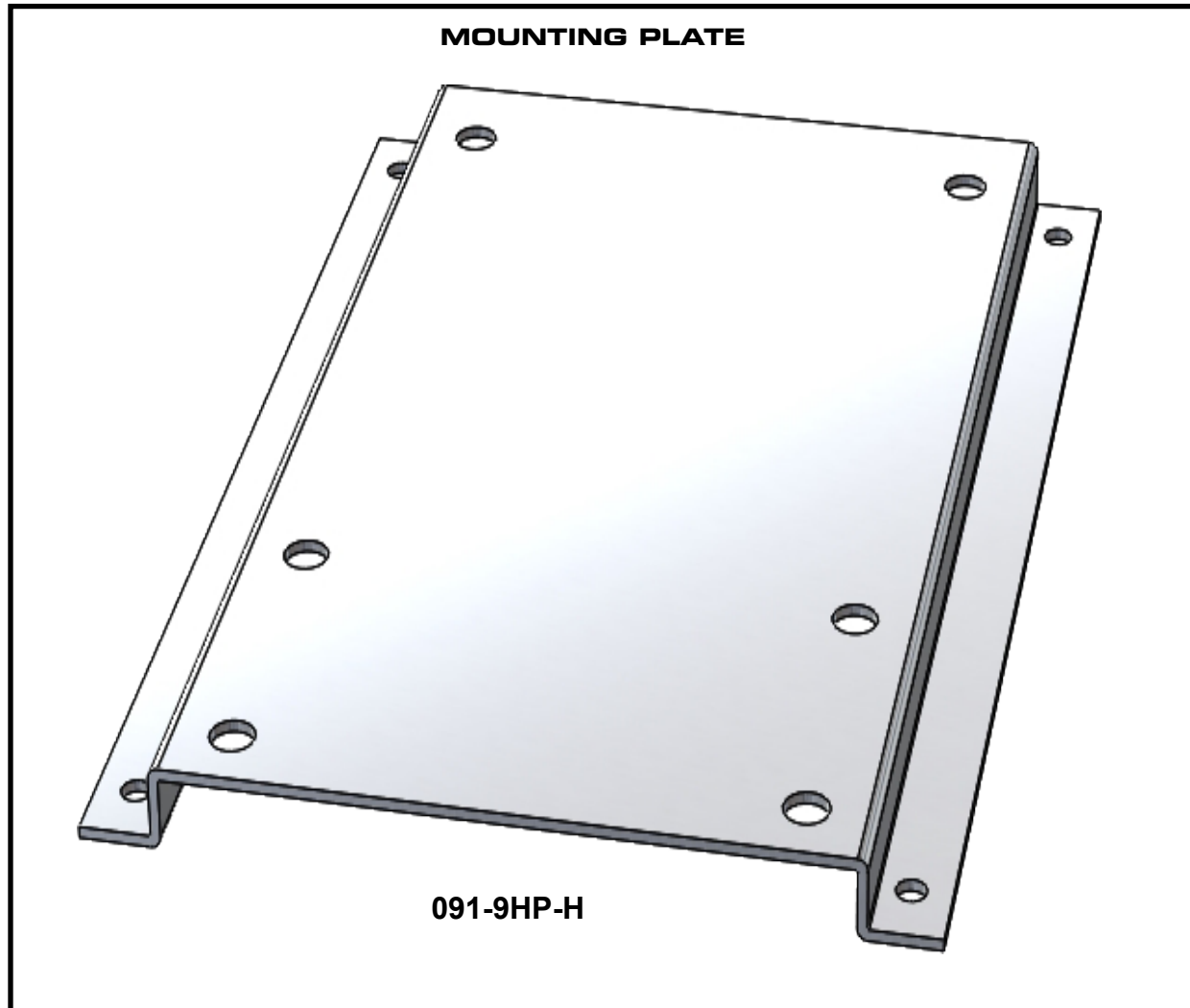

**CAUTION: WATER IN THE PUMP OUTLET  
WILL INDUCE FAILURE**

**WATER DAMAGE OR OPERATING AUTO PUMP  
OVER 100 PSI WILL VOID WARRANTY**



# INSTALLATION RECORD

---

DATE INSTALLED \_\_\_\_\_

INSTALLED BY \_\_\_\_\_

VEHICLE IDENTIFICATION \_\_\_\_\_

VEHICLE OWNER \_\_\_\_\_

# WARRANTY POLICY

---

Auto-Pump products of Kusssmaul Electronics Company Inc. are warranted to be free of defects of material or workmanship. Liability is limited to repairing or replacing at our factory, without charge, any material or defects which become apparent in normal use within 2 year from the date the equipment was shipped. Equipment is to be returned, shipping charges prepaid and will be returned, after repair, shipping charges paid.

Kusssmaul Electronics Company, Inc. shall have no liability for damages of any kind to associated equipment arising from the installation and/or use of the Kusssmaul Electronics Company, Inc. products. The purchaser, by the acceptance of the equipment, assumes all liability for any damages which may result from its installation, use or misuse, by the purchaser, his or its employees or others.



Members of  
Fire and Emergency  
Manufacturers and  
Service Association



Members of  
National Fire  
Protection  
Association



Members of  
Fire Apparatus  
Manufacturers  
Association



---

170 Cherry Avenue  
West Sayville, NY 11796  
[www.kusssmaul.com](http://www.kusssmaul.com)



Ph: 800-346-0857  
Fax: 631-567-5826  
[sales@kusssmaul.com](mailto:sales@kusssmaul.com)