

FOAM MAKER MODEL- FM



TECHNICAL DATA :

MODEL	FM
SIZE	50, 65, 80 NB Inlet
WORKING PRESSURE	Minimum 2.8 Kg. / sq. cm. (40 PSI) Maximum 7 Kg. / sq.cm. (100 PSI)
FLANGE CONNECTION	ANSI B 16.5 class 150#
FINISH	Red epoxy painted
WEIGHT	50 NB - 9.9 Kg 65 NB - 14.0 Kg 80 NB - 19.8 Kg
ORDERING INFORMATION	a) Model and Inlet size b) Inlet Pressure c) Foam Solution flow required d) Inlet Outlet flange e) Type of Foam oncentrate used.

APPLICATION

Foam Maker is used in one of the most common application to protect tank seal in vertical liquid storage tank with internal floating roof with low expansion foam system. The application of aspirated foam is on the basis of the risk comprising the area in the annular ring between the rim of the floating roof and the tank shell. The Foam system design guidelines generally used are in accordance with NFPA 11 standard. The Foam Makers are defined by NFPA 11 as Type II discharge outlets for delivering the low expansion aspirated foam to the seal. The Foam Makers are widely used with the Inline foam inductor, Balance pressure foam proportioning system, Bladder tank system or Foam tenders.

SPECIFICATION

Foam Maker is an air aspirating foam generator connected to the foam pourer to deliver the aspirated foam gently into the tank seal area. Foam maker covers wide range of foam solution rates from 75 to 1200 litres per minute at 2.8 to 7 kg/sq.cm inlet pressure. Each foam maker is supplied with an orifice plate, designed for the required flow at inlet pressure. The orifice is field replaceable in the event of change in design parameters. The foam is produced by introducing air into the foam solution stream. The inlet of foam maker is designed to create venturi jet which draws air into the foam solution stream. The air is drawn into the foam solution through holes located on the foam maker covered with stainless steel screen to exclude nesting birds



and insects. The aerated foam is directed into the pourer for the gentle application of the expanded foam. The pourers are available in different models.

SYSTEM DESIGN REQUIREMENT

For essential requirement of appropriately designed foam pouring system for storage tanks refer NFPA-11 / OISD-117 / TAC / Governmental codes or ordinances wherever applicable.

a) Minimum Number of Foam Makers

The maximum spacing between two foam makers shall be 24.4 metres for foam dam height of 610mm and 12.2 metres for foam dam height of 305mm. (Refer NFPA-11)

When two or more foam makers are required they shall be spaced equally around the tank periphery and each foam maker shall be sized to deliver foam at the same rate.

As per reference to OISD-117 standard maximum spacing between two foam makers shall be 24 metres of shell perimeter based on 600mm foam dam height and minimum of two Foam Makers are to be provided.



b) Minimum Foam Solution Application Rate

The tank area for foam application is defined as annular area between foam dam and tank shell.

$$\frac{\pi d_1^2}{4} - \frac{\pi d_2^2}{4} = 'A'$$

Where d₁ is tank shell diameter and d₂ is diameter of the foam dam, 'A' is annular area between foam dam and tank shell.

Foam solution application rate is 'A' X 12 litres/min. (Reference OISD-117)

c) Minimum System Operating Time

For minimum system operating time, sufficient foam concentrate must be stored as per NFPA-11 / OISD-117 / TAC / Governmental codes and ordinances wherever applicable.

TESTING AND MAINTENANCE

Qualified and trained person must commission the system. After few initial successful tests an authorized person must be trained to perform inspection and testing of the system. It is recommended to carry out physical inspection of the system regularly. The system must be fully tested at least once in a year or in accordance to the standards of the organization having local jurisdiction.

Do not turn off the system or any valve to make repair or test the system, without placing a roving Fire Patrol in the area covered by the system. The Patrol should continue until the system is putback in service. Also inform the local security guard and control alarm station, so as to avoid false alarm.

Each system is to be flushed properly. To test the Foam Maker without discharging the foam into the tank seal area the foam maker is to be rotated 180° away from the wind shield. The air screen is to be inspected periodically for the obstruction of air inlet holes. If any obstruction is noticed, remove same and flush, if necessary. The foam makers outlet and pourer, if exposed to atmospheric condition, should be periodically inspected for nest and other obstructions. The obstruction, if noticed, must be removed and flushed to clear the discharge path.

NOTE

A PROVISION IS TO BE MADE FOR PRESSURE GAUGE MOUNTING AT INLET OF FOAM MAKER, WHICH CAN BE PLUGGED AFTER SUCCESSFUL COMMISSIONING OF THE SYSTEM. THIS PROVISION WILL HELP TO ANALYSE THE SYSTEM WHILE COMMISSIONING.

SELECTION OF KV FOAM MAKER

FOAM MAKER SIZE	K-FACTOR
50 NB	43.4 to 127
65 NB	115.4 to 254
80 NB	230.9 to 508

For selecting the size of Foam Maker, following formula to be used:

$$Q = KV\sqrt{P}$$

Where Q = Total solution flow in litres per minute

K = Foam Maker constant P = Inlet pressure in Kg. / sq. cm.

Example

To find K-Factor Q = 150 LPM

$$P = 3.5 \text{ Kg/sq.cm.}$$

$$K = 150 \div \sqrt{3.5} = 80.17$$

The K-Factor 80.17 falls within the range of the Foam Maker having 50 NB size. Hence 50 NB size Foam Maker is to be selected.

The Foam Maker can also be selected from the graph.

Note :

1. It is recommended to select next higher size of Foam Maker when K-factor is very much closer to upper limit of the Model.
2. For the best performance, the inlet pressure at the Foam Maker should be 2.8 Kg/sq.cm. or higher.

CALCULATION EXAMPLE

Type of tank : Floating roof tank.

Tank diameter : 42 meters

Foam dam size : 0.6 metres from shell.
0.6 metres height.

Product stored : Hydrocarbon

Inlet Pressure at Foam Maker : 3.5 Kg./sq.cm.

$$\begin{aligned} \text{Area of Dam} &= \frac{\pi}{4} (d_1^2 - d_2^2) \\ &= \frac{3.14}{4} \times (42^2 - 40.8^2) \\ &= 78.03 \text{ sq.m.} \end{aligned}$$

a) Minimum solution application rate
 = Area of dam X 12.2 LPM/min/sq.m.
 = 78.03 X 12.2 (*)
 = 951.96 LPM

(*) 12.2 LPM/sq.m. is as per NFPA-11 (12.0 LPM/sq.m. as per OISD-117) recommendations or it should be as per prevailing rules of local authority having jurisdiction.

b) Number of Foam Makers

Circumference of tank = d
 = $\pi \times 3.142 \times 42$
 = 131.95 mtrs.

Maximum spacing permissible with 0.6 meters.
 Foam dam height, (Ref : NFPA-11) - 24.4 meters
 (24.0 meters to be considered as per OISD-117).

Number of Foam Makers = $131.95 \div 24.4$
 = 5.40
 = 6 units.

c) Foam Maker Capacity

$$= \frac{\text{Foam solution rate in LPM}}{\text{Number of Foam Maker}}$$

= 951.96 ÷ 6

= 158.66 LPM at 3.5Kg./sq.cm.

say 160 LPM at 3.5Kg./sq.cm.

d) Selection of KV Foam Maker

The K-factor for 160 LPM at 3.5 Kg/sq.cm.
 $K = Q \div \sqrt{P}$
 = $160 \div \sqrt{3.5}$
 = 85.52

The K-factor 85.52 is within the range of 50 NB size of Foam Maker. Hence, six Foam Makers of FM-50NB size is to be selected.

Note :
 THE ABOVE ARE THEORETICAL CALCULATIONS. IT IS, THEREFORE, RECOMENDED THAT SYSTEM DESIGNER SHOULD CONSIDER AN APPROPRIATE FACTOR OF SAFETY

e) Minimum Foam Concentrate Required

$$\text{Minimum foam concentrate} = \left[\frac{\text{Foam solution flow rate in LPM}}{\text{Foam concentrate induction rate in \%}} \right] \times \left[\frac{\text{Minimum operating time in minutes}}{100} \right]$$

= 951.96 X $\frac{3}{100}$ X 20*

(*Reference NFPA-11)

= 517.17 add 5% = 543 litres.
 say 550 litres

The supplementary hose stream requirement is also to be considered. 100% reserve stock or stock of foam concentrate is to be maintained as per local authority having jurisdiction.

Note :
 The additional quantity of 5% is general guideline, however system designer has to work-out this percentage considering factor of safety, pipeline, minimum level for induction in storage tanks etc.

FOAM MAKER

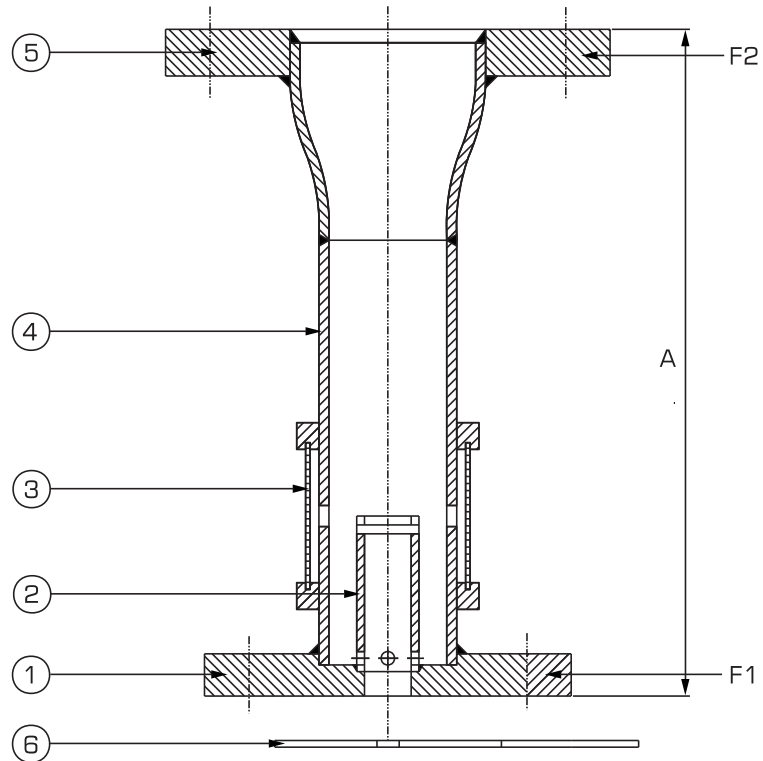

DIMENSION in millimetre (Approximate)

INLET (F1)	OUTLET (F2)	A
50NB	80 NB	300
65 NB	100 NB	400
80 NB	150 NB	475

- Dimension of inlet / outlet flanges (F1 / F2) are as per ANSI B16.5

- Pipes used are ERW (Seamless Pipes are optional on request)

PART LIST

ITEM NO.	DESCRIPTION	MATERIAL
1	INLET FLANGE	ASTMA105
2	AERATING PIPE	STEEL PIPE
3	AIR STRAINER	S.S. 304
4	FOAM MAKING CHAMBER	STEEL PIPE
5	OUTLET FLANGE	ASTMA105
6	ORIFICE PLATE	S.S. 304

PRESSURE VS FLOW PERFORMANCE CHARACTERISTIC

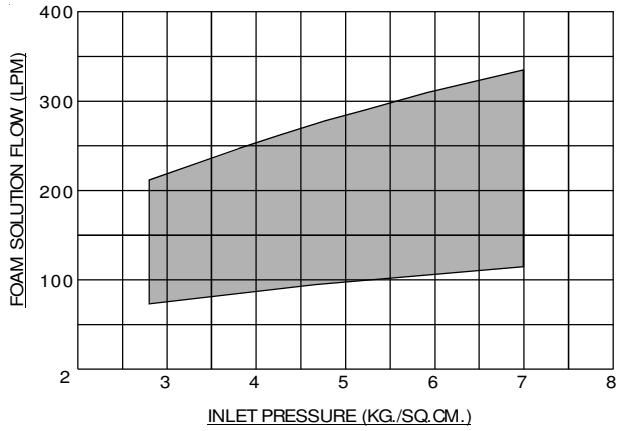

SIZE 50NB

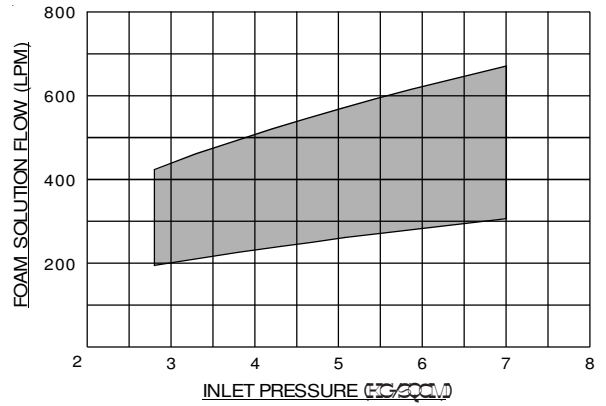

SIZE 65NB

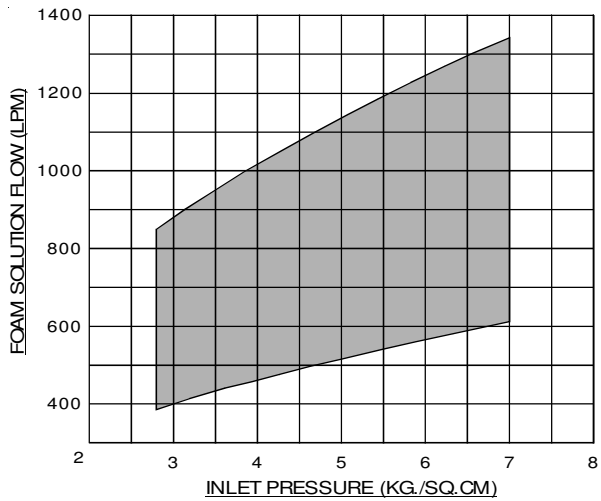

SIZE 80NB

TYPICAL INSTALLATION OF FOAM MAKER WITH FOAM POURER - MODEL : FP55

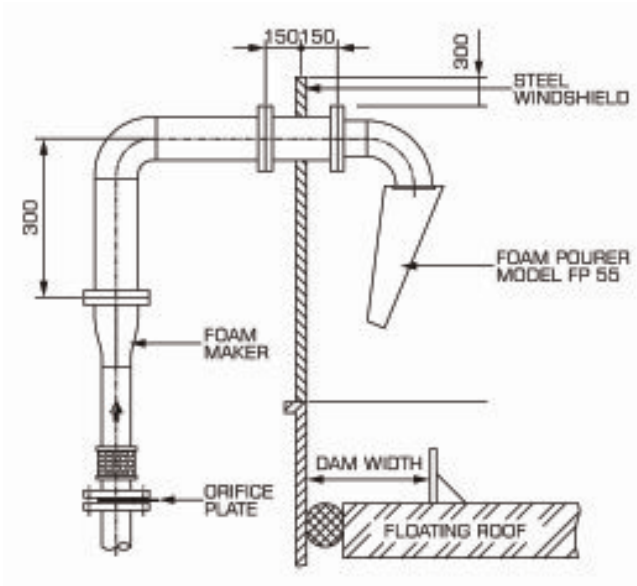

The Foam Pourer, Model FP 55 is fabricated out of steel pipe, pipe fittings and epoxy painted. The pourer is having stainless steel screen which prevents entry of nesting birds and insects. The screen also reduces the expanded foam velocity and allow the foam to gently slide down the tank wall into the seal dam area.

LIMITED WARRANTY

Products manufactured by K.V. FIRE CHEMICALS (I) PVT.LTD. are warranted against defects in material and workmanship for a period of Two (2) years from the date of shipment. KV's obligation under this warranty is limited to replace or repair the products or its parts, which are shown to KV's examination to be in a defective condition attributable to KV. No warranty is given for products or components which have been subject, to misuse, improper installation, corrosion, wear and tear, improper storage, modification or repaired. If the defect attributable to KV cannot be rectified by repair or replacement, then KV may elect to refund the purchase price of the equipment in complete discharge of its obligation under this Limited Warranty.

IN NO EVENT SHALL K.V. FIRE CHEMICALS (I) PVT. LTD. BE LIABLE IN CONTRACT, STRICT LIABILITY OR ANY OTHER LEGAL THEORY, FOR INCIDENTAL, IN-DIRECT, SPECIAL OR CONSEQUENTIAL DAMAGES, INCLUDING DAMAGES. FOR INJURY TO PERSON OR DEATH OR DAMAGE TO PROPERTY AND / OR PENALTIES RESULTING FROM ANY PRODUCTS OR COMPONENT MANUFACTURED OR ASSEMBLED BY KV. THIS IS LIMITED WARRANTY ONLY. KV DISCLAIMS WITH RESPECT TO THE PRODUCTS ALL IMPLIED WARRANTIES OF MERCHANTABILITY AND ALL IMPLIED WARRANTIES OF FITNESS FOR A PARTICULAR PURPOSE. THERE IS NO WARRANTY OF ANY NATURE MADE BY KV BEYOND AS STATED ABOVE.

NOTICE :

The equipment presented in this bulletin is to be installed in accordance with the latest publication standards of NFPA or other similar organisations and also with the provision of government codes or ordinances wherever applicable. The information provided by us are to the best of our knowledge and belief, and are general guidelines only. Site handling and installation control is beyond our reach. Hence we give no guarantee for result and take no liability for damages, loss or penalties whatsoever, resulting from our suggestion, information, recommendation or damages due to our product. Product development is a continuous programme of K.V. FIRE CHEMICALS (I) PVT. LTD. and hence the right to modify any specification without prior notice is reserved with the company.