

# **H**HN<sup>®</sup> FR SERIES

Fire and Rescue Rubber Suspension 40 - 48K

- Exceptional performance
- Outstanding durability
- Low life cycle costs

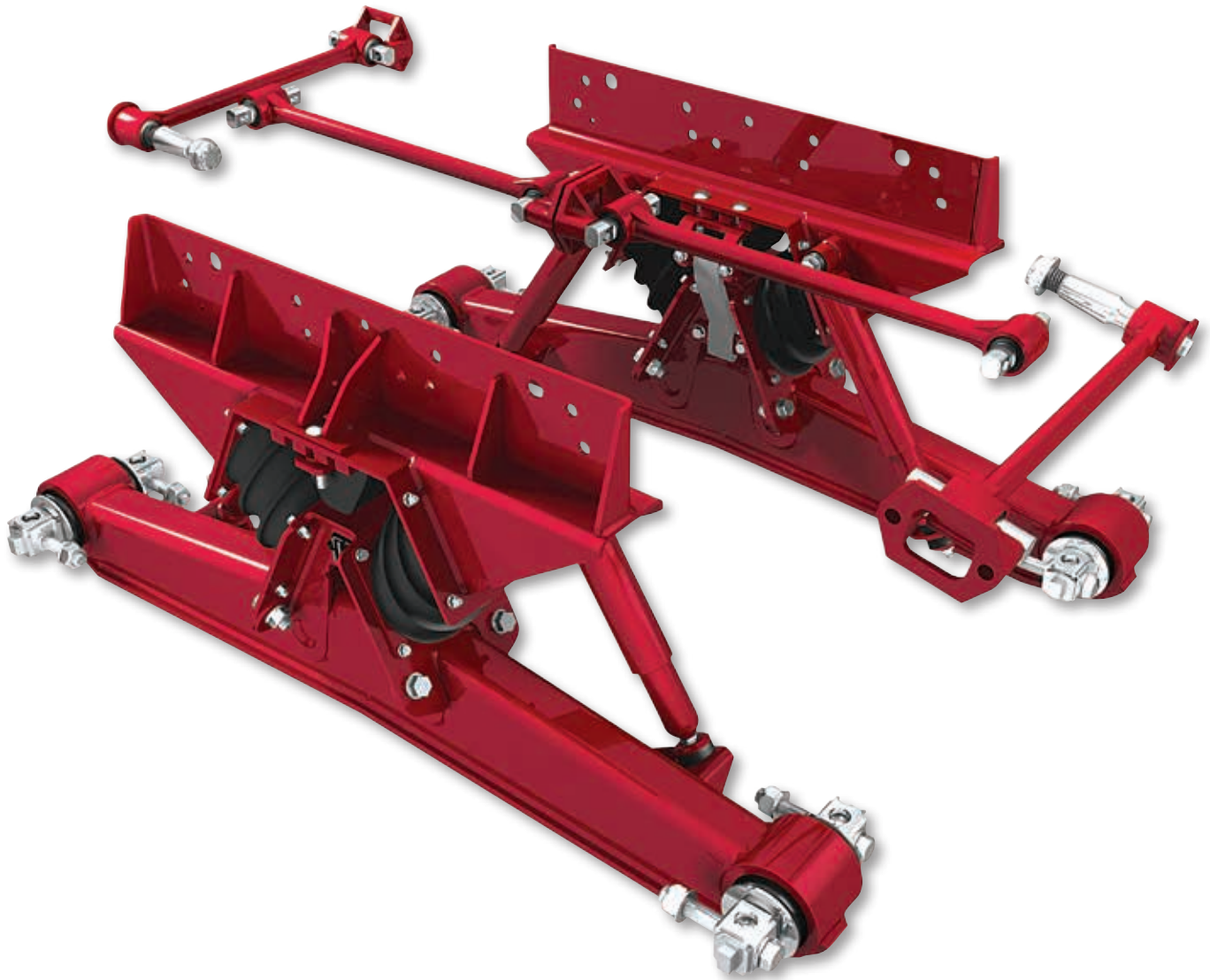

To learn more about HN FR Series,  
call 855.743.3733 or visit  
[www.hendrickson-fire.com](http://www.hendrickson-fire.com)

**H**HENDRICKSON  
*The World Rides On Us<sup>®</sup>*

# HN® FR SERIES Features and Benefits

## VariRate® Spring System

- Delivers a combination of superior stability, articulation and ride
- System can be tailored to meet the specific needs of unique vehicle applications

## Rubber Bolster Springs

- Lightweight, diagonally mounted rubber bolster springs deliver a smooth ride and outstanding articulation
- Wide spring centers enhance stability

## Auxiliary Springs

- Engage to provide added stability for more demanding applications

## Equalizing (Walking) Beam

- Distributes load equally between both axles for improved traction
- Center bushing eliminated for reduced maintenance

## Saddle Assembly

- Weight-saving, high-strength design increases carrying capacity and durability

## Rebound Control Strap

- Protects bolster springs from severe rebound tension

## Torque Rods

- Enhance handling during braking and cornering
- Transverse rods ensure axle position and lateral stability
- Longitudinal rods engineered to optimize resistance to axle wind-up during acceleration and braking

## Bar Pin Beam End Connection

- Extends bushing life and allows axle alignment capability for improved tire life

## Shock Absorbers

- Specially tuned to reduce wheel hop and enhance ride quality and handling

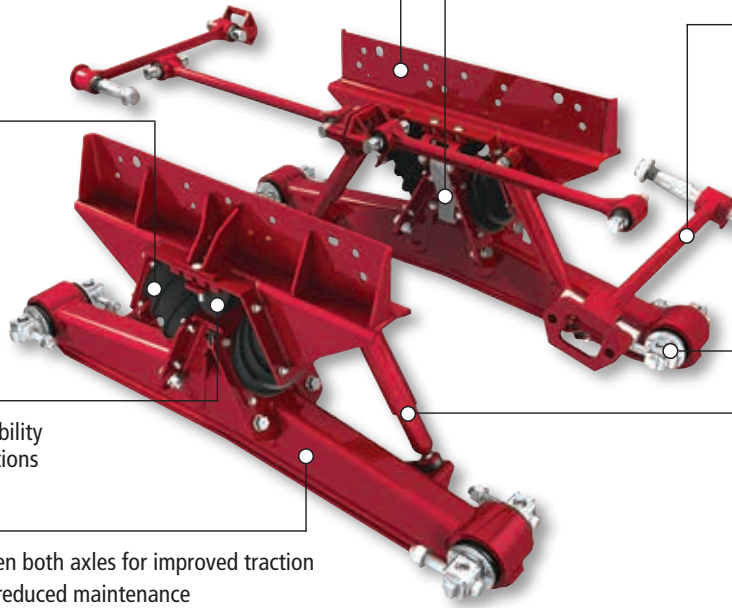

## HN FR Specifications

	HN 402FR	HN482FR
<b>Suspension Weight<sup>1</sup></b>	888 lbs.	911 lbs.
<b>Suspension Weight<sup>2</sup></b>	40,000 lbs.	48,000 lbs.
<b>GVW Approval<sup>3</sup></b>	73,000 lbs.	80,000 lbs.
<b>Diagonal Articulation<sup>4</sup></b>	17 in.	17 in.
<b>Ride Heights</b>	9.5, 10.5, 11.5, 13.25 and 15.5 in.	9.5, 10.5, 11.5, 13.25 and 15.5 in.
<b>Axle Spacing</b>	52, 54, 60, 72.5 in.	54, 60, 72.5 in.

1. Suspension weight includes complete suspension, as shown above, at 9.5-in. ride height and 54-in. axle spacing.

2. Capacity ratings approved for fire and rescue applications only.

3. Contact Hendrickson for applications that may exceed GVW approval ratings.

4. Suspension articulation may exceed vehicle's capability and may be limited by vehicle manufacturer; vehicle manufacturer installed axle stops may restrict suspension's articulation.

- Hendrickson approves the use of HN FR in fire and rescue vehicle applications. All such applications must comply with applicable Hendrickson specifications and must also be approved by the respective vehicle manufacturer with the vehicle in its original, as-built configuration. Contact Hendrickson and the respective vehicle manufacturer for approval of additional applications.
- For additional details regarding specifications; applications; capacities; and operating, service and maintenance instructions, refer to applicable Hendrickson technical literature (available at [www.hendrickson-intl.com](http://www.hendrickson-intl.com)) or contact Hendrickson at 855-743-3733.
- Actual product performance may vary depending upon vehicle configuration, operation, service and other factors.

Call Hendrickson at **630.910.2800** or **855.RIDERED (743.3733)** for additional information.



[www.hendrickson-fire.com](http://www.hendrickson-fire.com)

**TRUCK COMMERCIAL VEHICLE SYSTEMS**  
 800 South Frontage Road  
 Woodridge, IL 60517-4904 USA  
 855.RIDERED (743.3733)  
 630.910.2800 • Fax 630.910.2899