

MONITOR - VAJRA 331

(CAST BRONZE)



TECHNICAL DATA

MODEL	VAJRA 331
NOMINAL SIZE	3 Inch (75 MM)
MAX. SERVICE PRESSURE	14 Bar (200 PSI)
MAXIMUM FLOW	1000 GPM (3800 LPM)
FACTORY HYDROSTATIC TEST PRESSURE	35 Bar (500 PSI)
SWIVEL JOINT	Bronze to IS 318 / ASTM B 62 with double row of Stainless Steel Ball Bearing and Grease Fittings.
NOZZLE THRUST REACTION IN Kg.	Flow in LPM X $\sqrt{\text{Pressure}}$ in Kg./sq.cm. X 0.0228
INLET CONNECTION	3" OR 4" (80 NB OR 100 NB) Flange to ANSI B16.5 #150, F.F.
OUTLET CONNECTION	3" BSP (M) or 2-1/2" BSP (M) or 2.5 NH
MONITOR ELEVATION	90 Deg. above horizontal & 45 Deg. below horizontal and optional 85 Deg. above horizontal & 0 or 15 or 30 Deg. below horizontal.
MONITOR ROTATION	360 Deg. continuous
MONITOR MOVEMENT	Manual
FINISH	Red RAL 3000
WEIGHT (Approx)	33 Kg
ORDERING INFORMATION	Specify Monitor Model, Inlet Flange Size and Outlet Connection

DESCRIPTION

The monitor Model- VAJRA-331 is durable manual controlled monitor for fixed installation as well as trailer mounted unit. The monitor is generally used for protection of flammable liquid storage tanks, loading racks, dykes marine and many other Industrial application.

The Monitor possess several design features that provides ease of operation, minimum maintenance and resistance to corrosive environments. The monitor is used with aspirating, non-aspirating and water nozzles with flow range upto 1000 GPM (3800 LPM).



The monitor has cast bronze 3 inch (75 MM) water way. The vertical and horizontal rotation is through corrosion resistant bronze swiveling joint with double row of stainless steel ball bearing. Both vertical and horizontal movement are controlled by handle with twist lock.

The monitor has large flow capability and can be manually operated by a single fire fighter. The design ensures to prevent jet reaction forces from effecting the horizontal and the vertical position of the monitor. The monitor has the ability for 360 deg. continuous horizontal rotation and angle of elevation is from 90 deg. above horizontal and 45 deg. below horizontal. Angle of elevation of 85 deg. above horizontal and 0 or 15 or 30 deg. below horizontal is available as optional.

The water vanes in discharge tube reduces the turbulence and friction loss, thus increasing the nozzle performance to achieve greater range. To ensure desired performance, the friction loss through monitor must be considered while selecting the nozzle and the flow through the monitor with reference to available base pressure at inlet of the monitor. For flow and jet reach data refer monitor nozzle data sheet.

INSTALLATION, TESTING AND MAINTENANCE

The monitor must be installed and operated carefully by a trained person, having good knowledge of equipment. Before assembly of the monitor to the supply piping, thoroughly flush the piping with water to avoid sand, residue, welding slag or other debris hindering the proper functioning of the monitor.

After few initial successful tests, an authorized person must be trained to perform the inspection and testing of the monitor.

The monitor should be ready for use. To achieve this condition, scheduled inspection and maintenance operation should be performed and it must be recorded in the maintenance register book indicating the requirement or recommendation. The recommended maintenance, procedure must be followed as given in the manual and also as per the local authority having jurisdiction.

It is recommended to carry out on weekly basis physical inspection of the monitor. The inspection should verify that no damage has taken place to any component and the monitor is ready for use.

Carry out functional test every month for the flow, regular rotation in horizontal and vertical plane for the entire operating range to observe any leakage.

Periodic proper greasing through grease nipple provided on bearing, worm wheel and worm shaft must be ensured. Use water resistant low friction synthetic grease. Lubrication is required for smooth operation.

Each monitor must be operated with the full flow in accordance to the guidelines of the organisation having local jurisdiction.

The owner is responsible for maintaining the equipment in proper operating condition.

CAUTION

- A trained personnel for fire fighting must use the monitor. Appropriate guidance & training must be given to reduce the risk or injury.
- The nozzle must be fixed to the monitor carefully, The flange bolts must be tightened uniformly.
- The piping must be able to withstand the horizontal reaction force. Serious injury to personnel and equipment can result from improper installation.
- When installing monitor it is critical that flange bolts be tightened uniformly to prevent cocking of the monitor relative to the flange or valve.
- Before flowing water from monitor, check that all personnel are out of stream path and stream direction will not cause avoidable property damage.

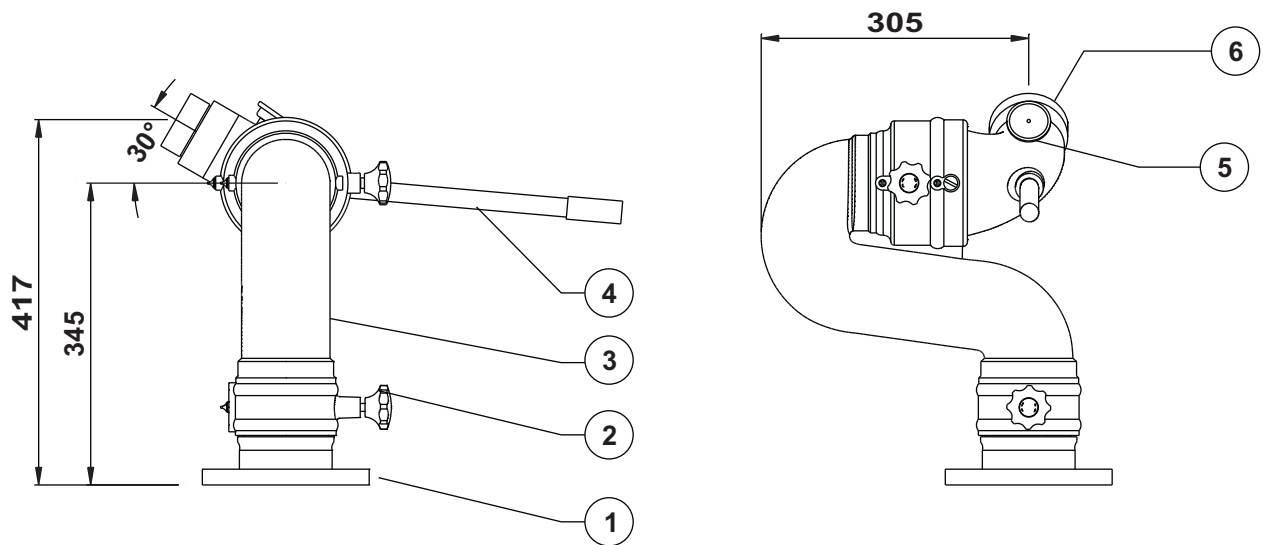

PART LIST

ITEM NO.	DESCRIPTION	MATERIAL SPECIFICATION
1	BASE FLANGE	BRONZE IS 318 / ASTM B62
2	LOCK	BRONZE IS 318 / ASTM B62
3	ELBOW	BRONZE IS 318 / ASTM B62
4	HANDLE	CARBON STEEL
5	PRESSURE GAUGE	0 to 16 kg/sqcm (Optional)
6	OUTLET ELBOW	BRONZE IS 318 / ASTM B62

Note :

- 1) Inlet flange standard size is 80 NB (3") or 100 NB (4") to ANSI B 16.24, 150#. 2) All dimensions in mm and are approximate.

LIMITED WARRANTY

HD FIRE PROTECT PVT. LTD. hereby referred to as HD FIRE warrants to the original purchaser of the fire protection products manufactured by HD FIRE and to any other person to whom such equipment is transferred, that such products will be free from defect in material and workmanship under normal use and care, for two (2) years from the date of shipment by HD FIRE. Products or Components supplied or used by HD FIRE, but manufactured by others, are warranted only to the extent of the manufacturer's warranty. No warranty is given for product or components which have been subject to misuse, improper installation, corrosion, unauthorized repair, alteration or un-maintained. HD FIRE shall not be responsible for system design errors or improper installation or inaccurate or incomplete information supplied by buyer or buyer's representatives.

HD FIRE will repair or replace defective material free of charge, which is returned to our factory, transportation charge prepaid, provided after our inspection the material is found to have been defective at the time of initial shipment from our works. HD FIRE shall not be liable for any incidental or consequential loss, damage or expense arising directly or indirectly from the use of the product including damages for injury to person, damages to property and penalties resulting from any products and components manufactured by HD FIRE. HD FIRE shall not be liable for any damages or labour charges or expense in making repair or adjustment to the product. HD FIRE shall not be liable for any damages or charges sustained in the adaptation or use of its engineering data & services. In no event shall HD Fire's product liability exceed an amount equal to the sale price.

The foregoing warranty is exclusive and in lieu of all other warranties and representation whether expressed, implied, oral or written, including but not limited to, any implied warranties or merchantability or fitness for a particular purpose. All such other warranties and representations are hereby cancelled.

NOTICE :

The equipment presented in this bulletin is to be installed in accordance with the latest publication standards of NFPA or other similar organisations and also with the provision of government codes or ordinances wherever applicable. The information provided by us are to the best of our knowledge and belief, and are general guidelines only. Site handling and installation control is beyond our reach. Hence we give no guarantee for result and take no liability for damages, loss or penalties whatsoever, resulting from our suggestion, information, recommendation or damages due to our product. Product development is a continuous programme of HD FIRE PROTECT PVT. LTD. and hence the right to modify any specification without prior notice is reserved with the company.

**HD FIRE PROTECT
PVT. LTD.**

C-3/6, THE NANDANVAN IND. ESTATE, L.B.S. MARG, THANE 400 604., INDIA.
• PHONES : + (91) 22 2583 5434 • 2582 6958 • 2582 6793
• FAX : +(91) 22 2581 2524 • 6796 9049
• EMAIL : info@hdfire.com • WEBSITE : www.hdfire.com