

# MONITOR - M - ISI MARKED

(CARBON STEEL, HOT DIP GALVANIZED)



## TECHNICAL DATA

MODEL	M (ISI)
MAXIMUM RATED	12 BAR (175 PSI)
NOMINAL WATERWAY SIZE	63mm, 75 mm and 100 mm
SPECIFICATION	Reference : IS:8442 - 1977
FLOW AT 7 Kg. / Sq. Cm PRESSURE	63 MM - 1750 LPM 75 MM - 2580 LPM 100 MM - 3500 LPM
FACTORY HYDROSTATIC TEST PRESSURE	25 Kg / Sq. Cm
NOZZLE THURST REACTION IN Kg.	Flow in LPM X $\sqrt{\text{Pressure}}$ in Kg./Sq. Cm. X 0.0228
INLET FLANGE SIZE	63 MM - 100 NB 75 MM - 100 NB 100 MM - 100 NB / 150 NB Flange dimension as per IS 6392-1971 Table 17 & 28
NOZZLE	Straight stream nozzle of Bronze or Aluminium material
MONITOR ELEVATION	90 Deg. above horizontal 45 Deg. below horizontal
ROTATION	360 Deg. continuous
WEIGHT (Approx)	63MM - 33 Kg 75MM - 40 Kg 100MM - 69 Kg
FINISH	Fire Red Shade 536 of IS: 5-1961 painted from outside
ORDERING INFORMATION	Specify Monitor Model Size and Inlet Flange Size
APPROVAL	ISI marked



and resistance to normally destructive environments. The monitor fitted with solid bore straight stream nozzle.

The monitor has welded carbon steel water way. All steel parts are hot dip galvanized and painted for excellent corrosion resistance. The vertical and horizontal rotation is through corrosion resistant bronze swiveling joint with double row of stainless steel ball bearing. Both vertical and horizontal movement are controlled with handle with twist lock.

The monitor has large flow capability and can be manually operated by a single fire fighter. The design ensures to prevent jet reaction forces from effecting the horizontal and the vertical position of the monitor. The monitor has the ability for 360 deg. continuous horizontal rotation and angle of elevation is adjustable with fix stop from +90 deg. above horizontal to -45 deg. below horizontal.

The water vanes in discharge tube reduces the turbulence and friction loss, thus increasing the nozzle performance to achieve greater range. To ensure desired performance, the friction loss through monitor must be considered while selecting the nozzle and the flow through the monitor with reference to available base pressure at inlet of the monitor. For flow and jet reach data refer table.

## DESCRIPTION

The monitor Model - M is durable manual controlled monitor for fixed installation as well as trailer mounted unit. The monitor is generally used for protection of flammable liquid storage tanks, loading racks, dykes marine and many other Industrial application.

The Monitor possess several design features that provides ease of operation, minimum maintenance

## **INSTALLATION, TESTING AND MAINTENANCE**

The monitor must be installed and operated carefully by a trained person, having good knowledge of equipment. Before assembly of the monitor to the supply piping, thoroughly flush the piping with water to avoid sand, residue, welding slag or other debris hindering the proper functioning of the monitor.

After few initial successful tests, an authorized person must be trained to perform the inspection and testing of the monitor.

The monitor should be ready for use. To achieve this condition, scheduled inspection and maintenance operation should be performed and it must be recorded in the maintenance register book indicating the requirement or recommendation. The recommended maintenance, procedure must be followed as given in the manual and also as per the local authority having jurisdiction.

It is recommended to carry out weekly physical inspection of the monitor. The inspection should verify that no damage has taken place to any component and the monitor is ready for use.

Carry out functional test every month for the flow, regular rotation in horizontal and vertical plane for the entire operating range to observe any leakage.

Periodic proper greasing through grease nipple provided on bearing, worm wheel and worm shaft must be ensured. Use water resistant low friction synthetic grease. Lubrication is required for smooth operation.

Each monitor must be operated with the full flow in accordance to the guidelines of the organisation having local jurisdiction.

The owner is responsible for maintaining the equipment in proper operating condition.

### **CAUTION**

- A trained personnel for fire fighting must use the monitor. Appropriate guidance & training must be given to reduce the risk or injury.
- The nozzle must be fixed to the monitor carefully. Do not over tighten the nozzle to the monitor. The flange bolts must be tightened uniformly.
- The piping must be able to withstand the horizontal reaction force. Serious injury to personnel and equipment can result from improper installation.
- When installing monitor it is critical that flange bolts be tightened uniformly to prevent cocking of the monitor relative to the flange or valve.
- Before flowing water from monitor, check that all personnel are out of stream path and stream direction will not cause avoidable property damage.

- Application of water or foam on an electric appliance can cause serious injury.
- The water supply to monitor must be increased / decreased gradually to prevent possible water hammer occurrence.
- Do not install shat offs on the outlet of the monitor.
- Do not exceed the maximum pressure or flow rating of the monitor. Exceeding the pressure or flow rating may cause injury or damage to the monitor.

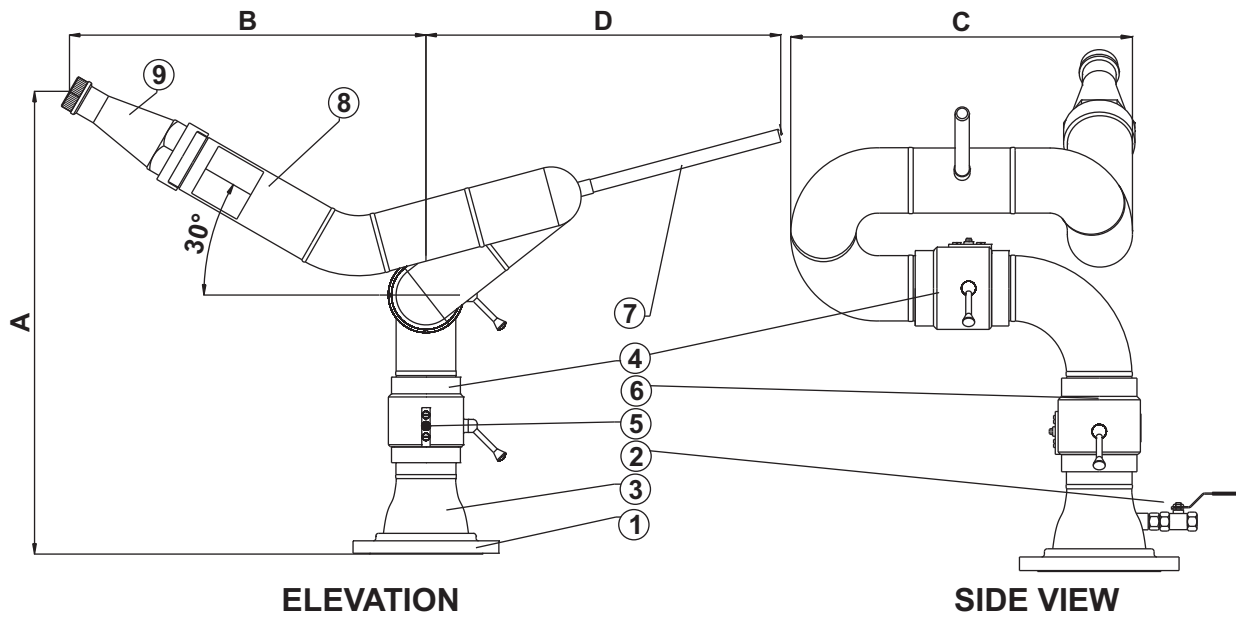

**DIMENSION** in millimeter (Approximate)

SIZE	A	B	C	D
63 NB	677	515	415	570
75 NB	720	560	470	620
100 NB	890	685	600	690

**PART LIST**

ITEM NO.	QTY.	DESCRIPTION	MATERIAL SPECIFICATION
1	1	BASE FLANGE*	IS:2002-1
2	1	DRAIN VALVE	BRASS
3	1	REDUCER	M.S. IS:1239 -II
4	2	SWIVEL JOINT	BRONZE IS:318 LTB-II
5	4	GREASE NIPPLE	BRASS
6	2	LOCK NUT	BRASS IS:291-I
7	1	HANDLE	M.S. IS : 1732-1971
8	1	WATER BARREL	SEAMLESSIS: 1239 (I)
9	1	NOZZLE	BRONZE IS:318 LTB-II OR

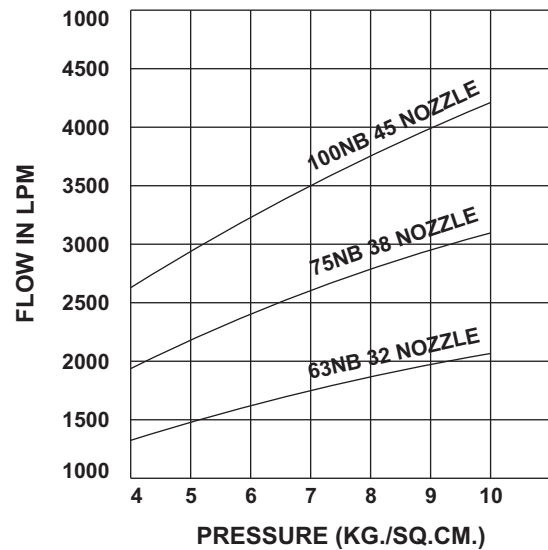
\* As per IS:6392

**HORIZONTAL STRAIGHT STREAM**

MONITOR SIZE	NOZZLE MODEL	FLOW IN LPM	WATER JET IN MTRS.
63	S 22 / 23 / 24	1750	53
75	S 32 / 33 / 34	2580	60
100	S 42 / 43 / 44	3500	64

Note:

1) Horizontal Straight Stream range is in still air with nozzle elevation at 30° to inlet flange at 1 to 1.5 meters above ground level and at 7 Kg./Sq.cm. nozzle pressure.

#### LIMITED WARRANTY

HD FIRE PROTECT PVT. LTD. hereby referred to as HD FIRE warrants to the original purchaser of the fire protection products manufactured by HD FIRE and to any other person to whom such equipment is transferred, that such products will be free from defect in material and workmanship under normal use and care, for two (2) years from the date of shipment by HD FIRE. Products or Components supplied or used by HD FIRE, but manufactured by others, are warranted only to the extent of the manufacturer's warranty. No warranty is given for product or components which have been subject to misuse, improper installation, corrosion, unauthorized repair, alteration or un-maintained. HD FIRE shall not be responsible for system design errors or improper installation or inaccurate or incomplete information supplied by buyer or buyer's representatives.

HD FIRE will repair or replace defective material free of charge, which is returned to our factory, transportation charge prepaid, provided after our inspection the material is found to have been defective at the time of initial shipment from our works. HD FIRE shall not be liable for any incidental or consequential loss, damage or expense arising directly or indirectly from the use of the product including damages for injury to person, damages to property and penalties resulting from any products and components manufactured by HD FIRE. HD FIRE shall not be liable for any damages or labour charges or expense in making repair or adjustment to the product. HD FIRE shall not be liable for any damages or charges sustained in the adaptation or use of its engineering data & services. In no event shall HD Fire's product liability exceed an amount equal to the sale price.

The foregoing warranty is exclusive and in lieu of all other warranties and representation whether expressed, implied, oral or written, including but not limited to, any implied warranties or merchantability or fitness for a particular purpose. All such other warranties and representations are hereby cancelled.

#### NOTICE :

The equipment presented in this bulletin is to be installed in accordance with the latest publication standards of NFPA or other similar organisations and also with the provision of government codes or ordinances wherever applicable.

The information provided by us are to the best of our knowledge and belief, and are general guidelines only. Site handling and installation control is beyond our reach. Hence we give no guarantee for result and take no liability for damages, loss or penalties whatsoever, resulting from our suggestion, information, recommendation or damages due to our product.

Product development is a continuous programme of HD FIRE PROTECT PVT. LTD. and hence the right to modify any specification without prior notice is reserved with the company.

**HD FIRE PROTECT  
PVT. LTD.**

C-3/6, THE NANDANVAN IND. ESTATE, L.B.S. MARG, THANE 400 604., INDIA.  
• PHONES : + (91) 22 2583 5434 • 2582 6958 • 2582 6793  
• FAX : +(91) 22 2581 2524 • 6796 9049  
• EMAIL : info@hdfire.com • WEBSITE : www.hdfire.com