

FOAM CHAMBER MODEL-FC



TECHNICAL DATA

MODEL	FC
SIZE	50, 65, 80, 100 & 150 NB inlet
WORKING PRESSURE	Minimum 2.8 Kg. / sq.cm. (40 PSI) Maximum 7 Kg. / sq.cm. (100 PSI)
FLANGE CONNECTION	ANSI B16.5 Class 150#
WEIGHT (Approx)	FC 50 - 28.0 Kg FC 65 - 35.0 Kg FC 80 - 52.0 Kg FC 100 - 78.0 Kg FC 150 - 108.0 Kg
VAPOUR SEAL RUPTURE PRESSURE	0.7 to 1.75 Kg./sq.cm. (10 PSI TO 25 PSI) Running water/Water foam solution pressure at the inlet of Foam Chamber
MAXIMUM PERMISSIBLE BACK PRESSURE ON VAPOUR SEAL	0.06 Kg./sq.cm. (0.9 PSI)
FINISH	Red RAL 3000
ORDERING INFORMATION	Specify a) Model and size b) Inlet pressure c) Foam solution flow required d) Inlet, outlet flange specification e) Type of foam concentrate used

APPLICATION

Foam Chamber is used in one of the most common application to protect vertical fixed roof (cone) liquid storage tanks, with or without internal floating roof with the low expansion foam system. The application of foam is on the basis that the risk comprises the total surface area of the fuel. The foam system design guidelines generally used are in accordance with NFPA-11, standard.

Foam Chambers are defined by NFPA-11 as Type II discharge outlets for delivering the foam to the surface of a flammable liquid. The Foam Chambers are widely used with the in-line foam inductor, Balance pressure foam proportioning system, Bladder tank proportioner or Foam tender.



SPECIFICATION

Foam chamber is an air aspirating foam discharge device, covering wide range of flow from 75 to 3600 litres per minute at 2.8 to 7 kg/sq.cm inlet pressure. The foam chamber contains a vapour seal to prevent the entry of vapour into the foam chamber and the foam solution pipe. Each foam chamber is supplied with an orifice plate, designed for the required flow and inlet pressure. The orifice is field replaceable in the event of change in design parameters. The foam is produced by introducing air into the foam solution stream. The inlet of foam chamber is designed to create venturi jet which draws air into the foam solution stream. The air is drawn into the foam solution through the holes located on the foam chamber covered with stainless steel screen to exclude nesting birds and insects. The aerated foam is directed into the deflector for the gentle application of the expanded foam. The deflectors are available in different models.

On removal of cover plate from the top of the chamber allows the system to be tested and to draw a sample of the expanded foam, without removing the vapour seal or disconnecting the foam chamber from the tank. Frangible glass bursting disc (vapour seal) can be replaced very easily.

SYSTEM DESIGN REQUIREMENT

The NFPA-11, a standard for low expansion foam, provides the essential requirement of an appropriate designed foam pouring system, which are identified and outlined as below:

The Foam Deflector is used with the Foam Chamber. The aerated foam from the Foam Chamber

is directed in to the deflector for the gentle application of the expanded foam. The deflector reduces the expanded foam velocity and allows the foam to slide down the tank wall.

a) Number of Foam Chamber

The number of foam chambers required is determined by the tank diameter. Where two or more foam chambers are required, they shall be spaced equally around the tank periphery and each Foam Chamber shall be sized to deliver foam at an approximately same rate. Please refer graph to select the unit that will provide the required minimum foam solution application rate at the available operating pressure of the Foam Chamber. For minimum number of Foam Chamber requirement, kindly follow the recommendations as per NFPA/OISD/TAC or as per the governmental codes or ordinances wherever applicable.

b) Minimum Foam Solution Application Rate

The minimum foam solution application rate is the rate at which the water and foam concentrate in correctly proportioned ratio should be delivered to the surface of a storage tank under protection to control and extinguish the fire. For minimum application rate requirement follow the recommendations as per NFPA/OISD/TAC or governmental codes or ordinances wherever applicable.

TESTING AND MAINTENANCE

Qualified and trained person must commission the system. After few initial successful tests an authorized person must be trained to perform inspection and testing of the system. It is recommended to carry out physical inspection of the system regularly. The system must be fully tested at least once in a year or in accordance with applicable NFPA/OISD/TAC standards or in accordance with standards of the organization having local jurisdiction.

Do not turn off the system or any valve to make repair or test the system, without placing a roving Fire Patrol in the area covered by the system. The Patrol should continue until the system is put back in service. Also inform the local security guard and control alarm station, so as to avoid false alarm.

Each system is to be flushed properly. The vapour seal must be replaced if the system has been operated. Normal testing of the chamber can be carried out by removing the cover plate from the top of the chamber. This allows the system to draw a sample of the expanded foam without removing the vapour seal or disconnecting the Foam Chamber from the tank.

The air screen is to be inspected periodically for the obstruction of air inlet holes. If any obstruction is noticed, remove the same and flush if necessary.

It is recommended to have regular maintenance programme to inspect the Vapour Seal Chamber discharge area and deflector for possible deposit or obstruction.

NOTE :

A PROVISION IS TO BE MADE FOR PRESSURE GAUGE MOUNTING AT INLET OF FOAM CHAMBER, WHICH CAN BE PLUGGED AFTER SUCCESSFUL COMMISSIONING OF THE SYSTEM. THIS WILL HELP TO ANALYSE THE SYSTEM WHILE COMMISSIONING.

Selection Of HD Foam Chamber

SIZE OF FOAM CHAMBER	K-FACTOR
50 NB	43.4 to 127
65 NB	115.4 to 254
80 NB	230.9 to 508
100 NB	461.8 to 1016
150 NB	923.6 to 1524.2

To select the size of the Foam Chamber use the following formula

$$Q = K \sqrt{P}$$

Q = Total solution flow in litres per minute.

K = Constant for Foam Chamber

P = Inlet pressure in kg/sq.cm.

Example

To find K-Factor

$$Q = 300 \text{ LPM}$$

$$P = 3.5 \text{ Kg/sq.cm.}$$

$$K = 300 \div \sqrt{3.5}$$

$$= 160.35$$

This K-Factor falls within the range of the Foam Chamber having 65 NB size. Hence 65 NB size of Foam Chamber should be selected.

The Foam Chamber size may also be selected with the help of the graph.

Calculation example

Tank type : Fixed roof storage tank

Tank diameter : 40 meters.

Foam concentrate to be used : AFFF 3%

Pressure at inlet of Foam Chamber : 3.5 kg/sq.cm.

Flash point of liquid stored in tank : -27°C.

$$\text{Surface area} = \frac{d^2 \div 4}{4}$$

$$= \frac{(3.14 \times 40^2)}{4}$$

$$= 1256 \text{ Sq. mts.}$$

$$\begin{aligned} \text{a) Foam solution application rate} &= *4.1 \text{ LPM / Sq.mts.} \times \text{Surface area} \\ &= 4.1 \times 1256 \\ &= 5150 \text{ LPM} \end{aligned}$$

*4.1 LPM is as per NFPA-11 (5 LPM as per OISD recommendations) or it should be as per prevailing rules of local authority having jurisdiction.

b) Number of Foam Chamber required for 40 metres diameter tank = 3 nos. minimum (Reference NFPA-11)

Capacity of Foam Chamber required

$$= 5150 \div 3$$

$$= 1717 \text{ LPM}$$

The K-Factor for flow of 1718 LPM at 3.5kg/sq.cm

$$K = Q \div \sqrt{P}$$

$$= 1717 \div \sqrt{3.5}$$

$$= 918.30$$

The K-Factor (918.30) falls within the K-Factor of 100 NB size of the Foam Chamber. Hence 3 units of 100 NB Foam Chamber with 1717 LPM capacity at 3.5 kg./sq.cm inlet pressure are to be selected.

NOTE :

THE ABOVE ARE THEORETICAL CALCULATIONS. IT IS, THEREFORE, RECOMENDED THAT SYSTEM DESIGNER CONSIDERS AN APPROPRIATE FACTOR OF SAFETY

c) Foam Concentrate Requirement

The fuel stored has flash point of 27°C. So the minimum system running duration recommended is 55 minutes. (Reference NFPA-11)

$$\text{The foam concentrate required} = \left[\frac{\text{foam solution application rate in LPM}}{5154} \right] \times \left[\frac{\text{percentage of foam concentrate}}{3} \right] \times \left[\frac{\text{system running time}}{55} \right]$$

$$= \frac{8505 \text{ litres.}}{100}$$

Add 5% = 8930 litres.

The supplementary hose stream requirement is also to be considered and 100% reserve stock to be maintained or as per local authority having jurisdiction.

The additional quantity of 5% is general guideline, however system designer has to work-out this percentage considering factor of safety, pipeline, minimum level for induction in storage tanks etc.

NOTE :

1. It is recommended to select next higher size of Foam Chamber when the K-Factor is very much close to upper limit of the model.
2. For the best performance the inlet pressure at the Foam Chamber should be 2.8 kg/sq.cm. or higher.

FOAM CHAMBER

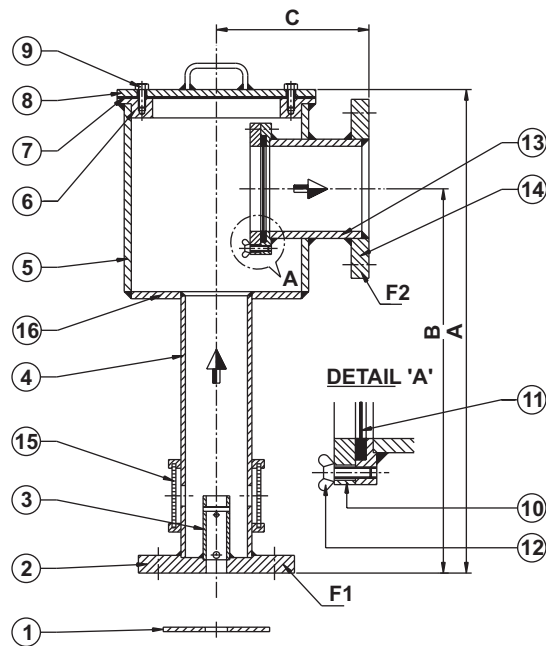

DIMENSION in millimetre (Approximate)

INLET (F1)	OUTLET (F2)	A	B	C
50 NB	80 NB	630	518	160
65 NB	100 NB	720	589	175
80 NB	150 NB	1050	895	225
100 NB	200 NB	1175	986	275
150 NB	250 NB	1250	1020	325

- Dimensions of inlet / outlet flanges (F1 / F2) are as per ANSI B16.5
- Pipes used are ERW (Seamless Pipes are optional on request)

PART LIST

ITEM NO.	DESCRIPTION	MATERIAL SPECIFICATION
1	ORIFICE PLATE	S.S. 304
2	INLET FLANGE	STEEL ASTM A105
3	AERATING PIPE	STEEL PIPE
4	FOAM MAKING CHAMBER	STEEL PIPE
5	FOAM CHAMBER	STEEL PIPE
6	CHAMBER FLANGE	STEEL
7	GASKET	NEOPRENE
8	INSPECTION HATCH	STEEL
9	BOLT	STEEL
10	VAPOUR SEAL RING & SEAL	STEEL
11	VAPOUR SEAL	GLASS
12	WING NUT & STUD	S.S. 304
13	DISCHARGE PIPE	STEEL PIPE
14	OUTLET FLANGE	STEEL ASTM A105
15	AIR STRAINER	S.S. 304
16	CHAMBER PLATE	STEEL

PRESSURE VS FLOW PERFORMANCE CHARACTERISTIC

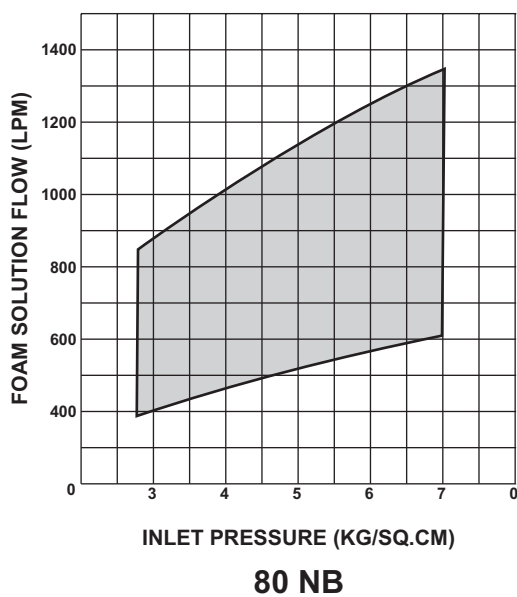
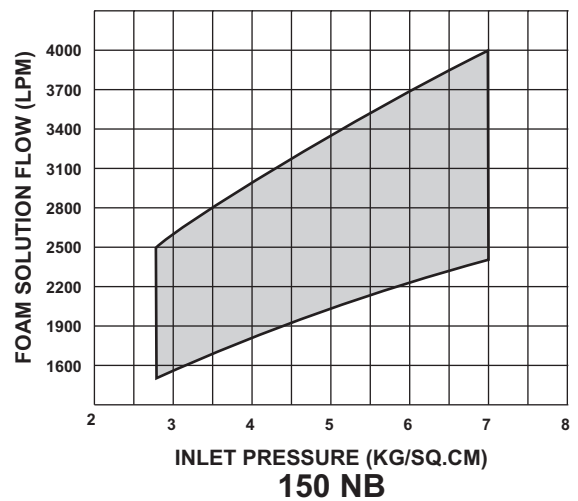
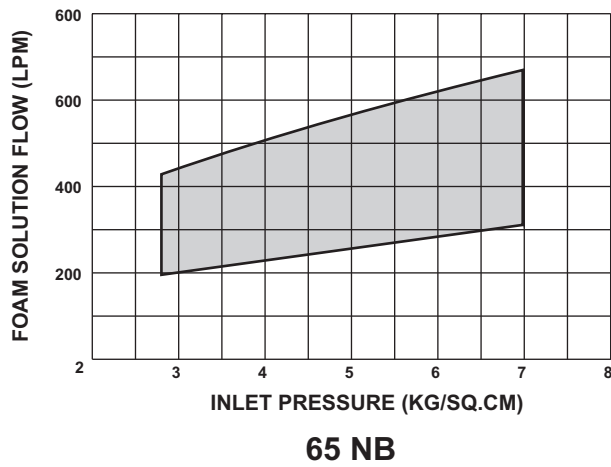
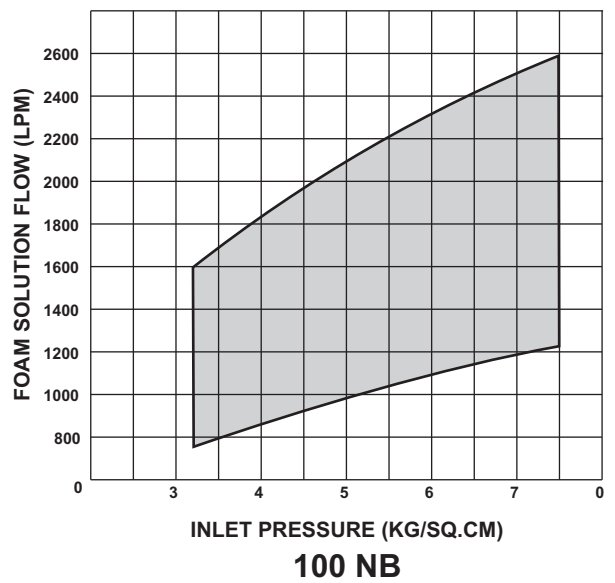
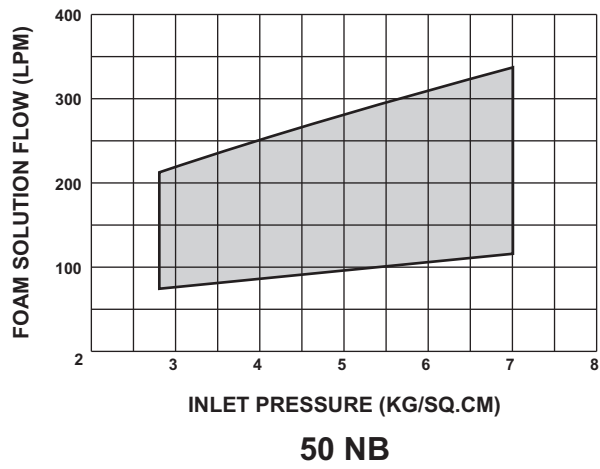

TYPICAL FOAM CHAMBER INSTALLATION WITH DEFLECTOR

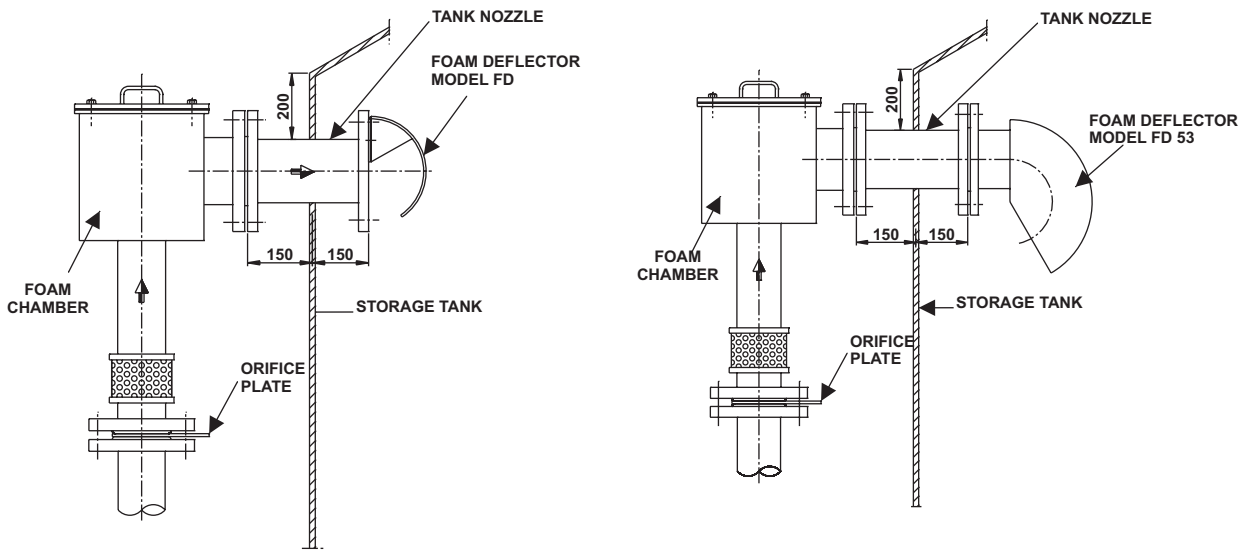

NOTE :

Above dimensions are general guideline only. The system designer can adopt the dimensions as per NFPA/TAC/OISD or as per the governing rules & ordinances having local jurisdiction.

LIMITED WARRANTY

HD FIRE PROTECT PVT. LTD. hereby referred to as HD FIRE warrants to the original purchaser of the fire protection products manufactured by HD FIRE and to any other person to whom such equipment is transferred, that such products will be free from defect in material and workmanship under normal use and care, for two (2) years from the date of shipment by HD FIRE. Products or Components supplied or used by HD FIRE, but manufactured by others, are warranted only to the extent of the manufacturer's warranty. No warranty is given for product or components which have been subject to misuse, improper installation, corrosion, unauthorized repair, alteration or un-maintained. HD FIRE shall not be responsible for system design errors or improper installation or inaccurate or incomplete information supplied by buyer or buyer's representatives.

HD FIRE will repair or replace defective material free of charge, which is returned to our factory, transportation charge prepaid, provided after our inspection the material is found to have been defective at the time of initial shipment from our works. HD FIRE shall not be liable for any incidental or consequential loss, damage or expense arising directly or indirectly from the use of the product including damages for injury to person, damages to property and penalties resulting from any products and components manufactured by HD FIRE. HD FIRE shall not be liable for any damages or labour charges or expense in making repair or adjustment to the product. HD FIRE shall not be liable for any damages or charges sustained in the adaptation or use of its engineering data & services. In no event shall HD Fire's product liability exceed an amount equal to the sale price.

The foregoing warranty is exclusive and in lieu of all other warranties and representation whether expressed, implied, oral or written, including but not limited to, any implied warranties or merchantability or fitness for a particular purpose. All such other warranties and representations are hereby cancelled.

NOTICE :

The equipment presented in this bulletin is to be installed in accordance with the latest publication standards of NFPA or other similar organisations and also with the provision of government codes or ordinances wherever applicable.

The information provided by us are to the best of our knowledge and belief, and are general guidelines only. Site handling and installation control is beyond our reach. Hence we give no guarantee for result and take no liability for damages, loss or penalties whatsoever, resulting from our suggestion, information, recommendation or damages due to our product.

Product development is a continuous programme of HD FIRE PROTECT PVT. LTD. and hence the right to modify any specification without prior notice is reserved with the company.



**HD FIRE PROTECT
PVT. LTD.**

C-3/6, THE NANDANVAN IND. ESTATE, L.B.S. MARG, THANE 400 604., INDIA.
 • PHONES : + (91) 22 2583 5434 • 2582 6958 • 2582 6793
 • FAX : +(91) 22 2581 2524 • 6796 9049
 • EMAIL : info@hdfire.com • WEBSITE : www.hdfire.com