

Features

For inside/hot air use
Excellent foaming properties
Recommended foam Fomtec LS EXP
DIN or ANSI flange option

Description

The Bele high-expansion foam generator is designed for total flooding systems or local application of high expansion foam. The massive volume of expanded foam will keep the water application to a minimum and extinguish through a combination of vapour suppression, cooling, oxygen reduction and wetting capability. Depending on foam concentrate used, it is also suitable for inside/hot air applications and polar solvents.

As standard, the Bele S-800 have stainless steel 304 body, carbon steel red epoxy painted (RAL 3000) connection piping and brass nozzles.

Application

The Bele high expansion foam generators can be used for applications such as:

- Aircraft hangars
- Ship Holds and engine rooms
- Power stations and transformers
- Gas turbine generators
- Flammable liquid storage
- LNG vapour suppression

Recommended foam concentrate:

- Fomtec LS EXP
- Fomtec LS xMax
- Fomtec LS aMax

Installation

The Bele S unit generator body, nozzle and pipework are shipped disassembled for packing/transport cost reasons. Foam generator mesh, connecting piping and nozzles need to be assembled before final installation.

Bele units can be installed for horizontal or vertical hi-ex foam application. As per figure 1.1, the generator body is equipped with mounting feet to allow mounting to either wall or ceiling. 3 x support brackets (not included) must be



properly fixated and able to carry the weight of the foam generator during operation.

The foam generator is attached to foam premix pipe system with flanged connection as standard. The foam premix feeding line should be equipped with a strainer mesh size no greater than 2,5 mm.

Operation

The Bele high expansion foam generators are water driven, passive type, and do not require any other power source to function in case of fire. It can be attached to any foam proportioning system such as inductor, bladder tank or foam pump.

For correct operation make sure that:

- Air at the suction side is clean (depending on foam concentrate used).
- The foam generator mesh must be clean and free of grease and other foreign material.

Maintenance

After use:

- Clean the strainer in foam premix line.
- Clean the generator externally and internally with fresh water.

Options

- Zinc plated inlet connection
- AISI 316 stainless steel inlet connection

Model	Flow rate L/min – 4 bar	Expansion ratio 4 bar ⁽¹⁾	Flow rate L/min – 5bar	Expansion ratio 5 bar ⁽¹⁾	Flow rate L/min – 6bar	Expansion ratio 6 bar ⁽¹⁾	Inlet connection	Weight Kg
BELE S-800	719	500-650:1	790	550-700:1	854	600-750:1	ANSI flange	138

(1): The expansion ratio is depending on foam concentrate type. Results achieved in full scale tests. Please consult Fomtec for most suitable hi-ex foam concentrate for your application.

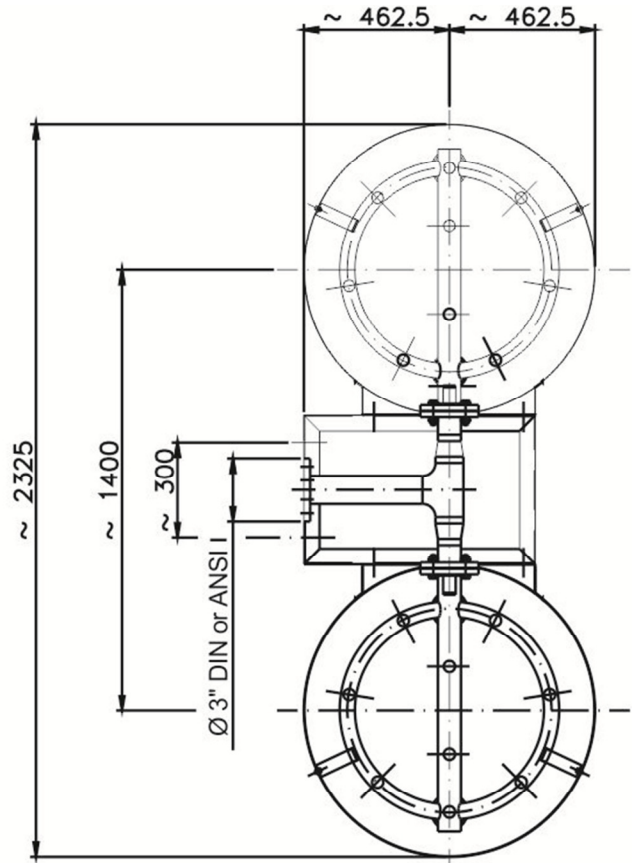
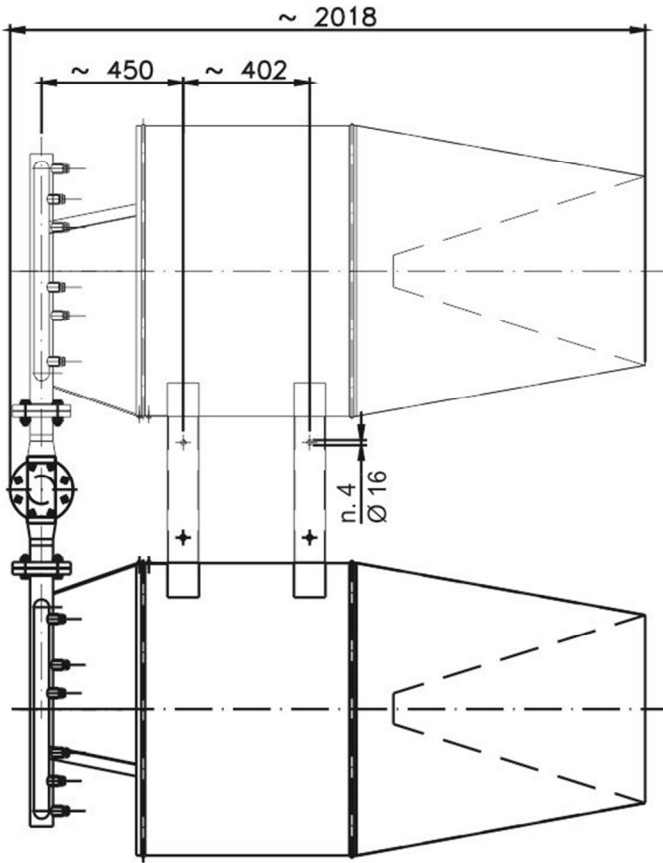

Dimensions in mm