

# WATER-BASED PORTABLE EXTINGUISHERS

## PRODUCT OVERVIEW

When a fire breaks out, there are bigger dangers than the ones you can see. The rising temperature of fuel around the fire, paper, and cloth are the best examples. Water is the only extinguishing agent that can instantly bring down the temperature of the fire and the area around it.

Ceasefire's water extinguishers use proprietary stored pressure technology, delivering a high power throw of water. It makes them more effective against the fire and allows the firefighter to stay at a safe distance from the flames. They are also packed with all the trademark features that make Ceasefire the fastest, safest, and most user-friendly extinguishers in the market today. Every Ceasefire extinguisher has ISO 9001 and CE certifications and conforms to ISI standards.



## ENGINEERING DRAWINGS

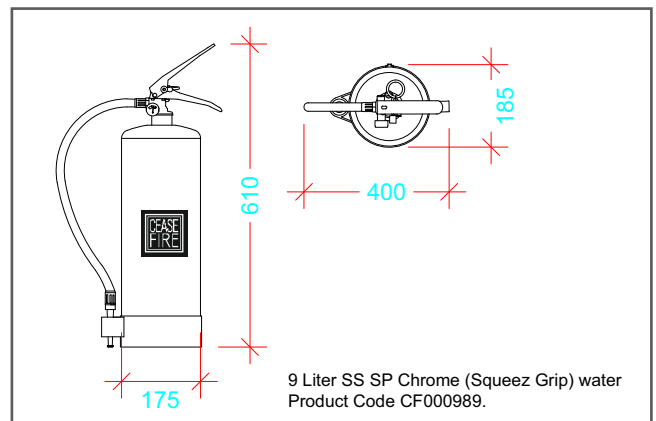
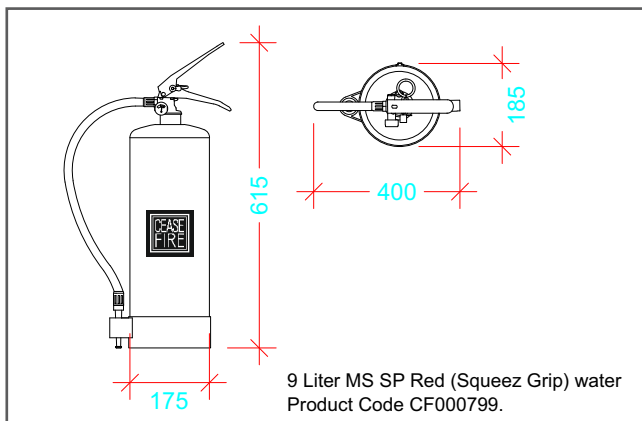
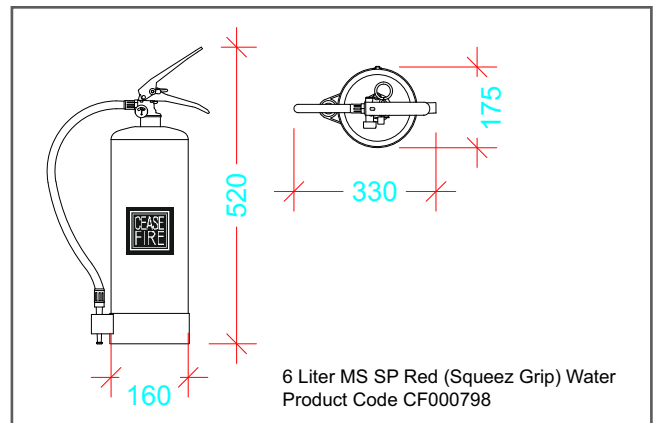
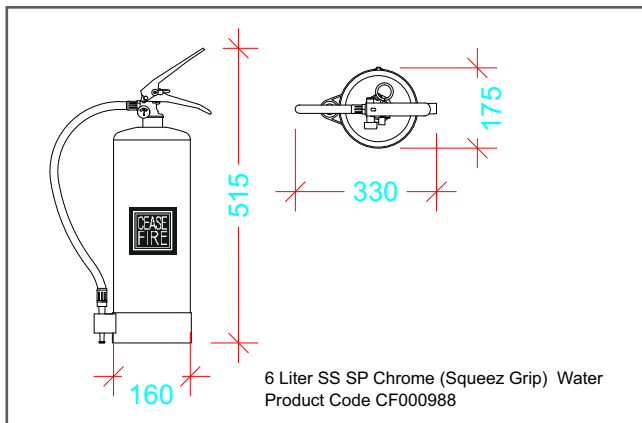



## TECHNICAL SPECIFICATIONS

Product Code	UOM	CF-000988	CF-000798	CF-000799	CF-000989
Description	—	Fire Ext Water 6L SS SP Chrome	Fire Ext Water 6L MS SP Red	Fire Ext Water 9L MS SP Red	Fire Ext Water 9L SS SP Chrome
Capacity of Agent	KG	6-5%	6-5%	9-5%	9-5%
Certification	—	PED EN3	PED EN3	PED EN3	PED EN3
Diameter of Shell	MM	160	160	175	175
Total Height (approx.)	MM	520	520	615	610
MOC of Shell	—	SS 304 (1.4301)	Steel Cr2 (DC01)	Steel Cr2 (DC01)	SS 304 (1.4301)
Min. Wall Thickness	MM	1.5	1.4	1.4	1.5
Test Pressure	BAR	35	35	35	35
Anti-Corrosive Treatment	—	NA	Outer & Inner surfaces were EP Powder coated having Thickness 50 Micron Min. RAL Shade 3000	Outer & Inner surfaces were EP Powder coated having Thickness 50 Micron Min. RAL Shade 3000	NA
Service Pressure	BAR	10	10	10	10
Type of Operating Mechanism	—	Squeeze Grip with NRV and Burst Disc.	Squeeze Grip with NRV and Burst Disc.	Squeeze Grip with NRV and Burst Disc.	Squeeze Grip with NRV and Burst Disc.
Type of Pressure Gauge	—	Magnetic Bourdon Tube Type	Magnetic Bourdon Tube Type	Magnetic Bourdon Tube Type	Magnetic Bourdon Tube Type



Product Code	UOM	CF-000988	CF-000798	CF-000799	CF-000989
Type of Dis. Fitting & Length	MM	EPDM Rubber Braided Hose Pipe with nozzle Length of Hose 400 mm (Min.)	EPDM Rubber Braided Hose Pipe with nozzle Length of Hose 400 mm (Min.)	EPDM Rubber Braided Hose Pipe with nozzle Length of Hose 500 mm (Min.)	EPDM Rubber Braided Hose Pipe with nozzle Length of Hose 500 mm (Min.)
Throw	METER	7	7	7	7
Min. Discharge Time	SEC.	9	9	9	9
Fire Rating	—	13A	13A	21A	21A
Operating Temperature Range	°C	From +5°C to +60°C	From +5°C to +60°C	From +5°C to +60°C	From +5°C to +60°C
Applicable to Type of Fire	—	A	A	A	A
Filled Weight Range*	KG	Approx 9.60	9.50 to 10.10	14.15 to 14.85	Approx. 13.40
Packed Weight Range (approx)**	KG	9.2	10.2	14.72	14.72
Packed Size Length x Width x Height	MM	175 x 175 x 585	175 x 175 x 585	230 x 220 x 670	230 x 220 x 670
Product Warranty	—	5	5	5	5

\*It includes Empty Extinguisher, Contents, Plastic Base, Hose / Horn and bracket.

\*\*It includes Empty Extinguisher, Contents, Packaging, Plastic Base, Hose / Horn and bracket.

**CERTIFICATIONS**

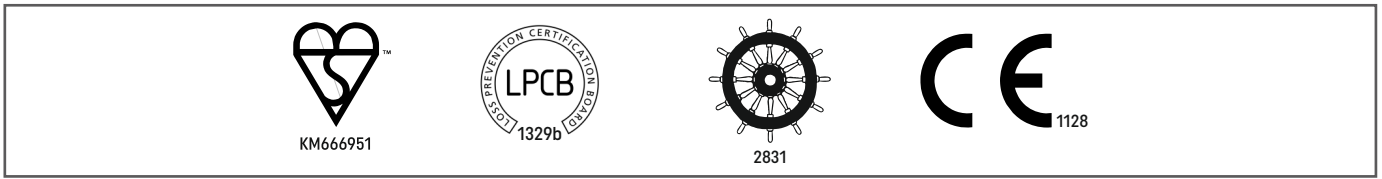

**PRODUCT PICTURES**



6 L

6 L

9 L

9 L



# WATER-BASED WHEELED EXTINGUISHERS

## PRODUCT OVERVIEW

When a fire breaks out, there are bigger dangers than the ones you can see. The rising temperature of fuel around the fire, paper, and cloth are the best examples. Water is the only extinguishing agent that can instantly bring down the temperature of the fire and the area around it.

Ceasefire's water extinguishers use proprietary stored pressure technology, delivering a high power throw of water. It makes them more effective against the fire and allows the firefighter to stay at a safe distance from the flames. They are also packed with all the trademark features that make Ceasefire the fastest, safest, and most user-friendly extinguishers in the market today. It not only comes with a 5-year warranty but also fights against class A and B fires.



## ENGINEERING DRAWINGS

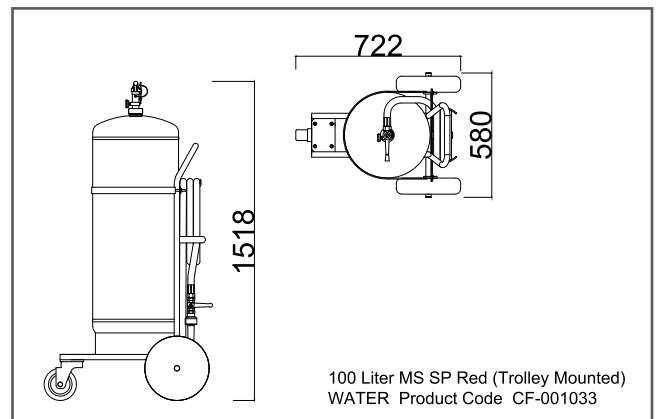
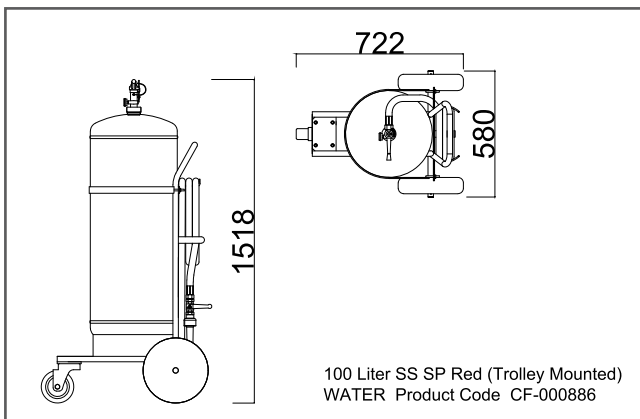
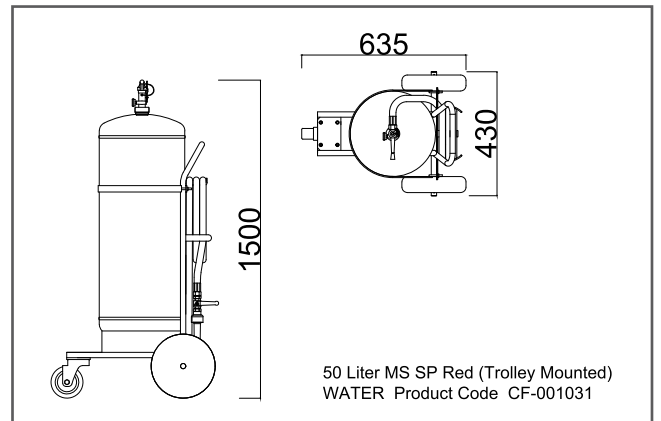
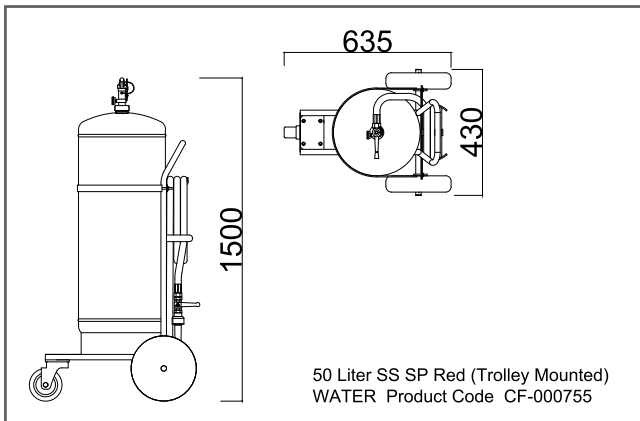



## TECHNICAL SPECIFICATIONS

Product Code	UOM	CF-000755	CF-001031	CF-000886	CF-001033
Description	—	Fire Ext Water 50L SS SP Red	Fire Ext Water 50L MS SP Red	Fire Ext Water 100L SS SP Red	Fire Ext Water 100L MS SP Red
Capacity of Agent	KG	50-5%	50-5%	100-5%	100-5%
Certification	—	En1866 PED	En1866 PED MED	En1866 PED	En1866 PED MED
Diameter of Shell	MM	300	300	400	400
Total Height (approx.)	MM	1510	1510	1520	1520
MOC of Shell	—	SS 304 (1.4301)	Steel Cr2 (DC01)	SS 304 (1.4301)	Steel Hr3 (DD13)
Min. Wall Thickness	MM	1.8	3	2	3.5
Test Pressure	BAR	30	30	30	30
Anti-Corrosive Treatment	—	Outer surfaces are EP Powder coated having Thickness 50 Micron Min. RAL Shade 3000	Outer surfaces are EP Powder coated having Thickness 50 Micron Min. RAL Shade 3000	Outer surfaces are EP Powder coated having Thickness 50 Micron Min. RAL Shade 3000	
Service Pressure	BAR	15	15	15	15
Type of Operating Mechanism	—	Operating Lever (Ball Valve)	Operating Lever (Ball Valve)	Operating Lever (Ball Valve)	Operating Lever (Ball Valve)
Type of Pressure Gauge	—	Magnetic Bourdon Tube Type	Magnetic Bourdon Tube Type	Magnetic Bourdon Tube Type	Magnetic Bourdon Tube Type



Product Code	UOM	CF-000755	CF-001031	CF-000886	CF-001033
Type of Dis. Fitting & Length	MM	EPDM Rubber Braided Hose Pipe with nozzle Length of Hose 5000mm (Min.)	EPDM Rubber Braided Hose Pipe with nozzle Length of Hose 5000mm (Min.)	EPDM Rubber Braided Hose Pipe with nozzle Length of Hose 5000mm (Min.)	EPDM Rubber Braided Hose Pipe with nozzle Length of Hose 5000mm (Min.)
Throw	METER	10	10	10	10
Min. Discharge Time	SEC.	40	40	80	80
Fire Rating	—	A	A	A	A
Operating Temperature Range	°C	5°C to +55°C	5°C to +55°C	5°C to +55°C	5°C to +55°C
Applicable to Type of Fire	—	Class A Fire	Class A Fire	Class A Fire	Class A Fire
Filled Weight Range*	KG	Approx. 91.50	Approx. 102.50	Approx. 158.20	Approx. 178.50
Packed Weight Range (approx)**	KG	102	113	181.93	205.28
Packed Size Length x Width x Height	MM	450 x 640 x 1555	450 x 640 x 1555	790 x 650 x 1650	790 x 650 x 1650
Product Warranty	—	5	5	5	5

\*It includes Empty Extinguisher, Contents, Hose / Nozzle and trolley.

\*\*It includes Empty Extinguisher, Packaging, Contents, Hose / Nozzle and trolley.

## CERTIFICATIONS

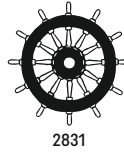

## PRODUCT PICTURES



50 L



100 L

\*v1' Published Date is 31-07-2022.

\*\*Regular R&D and product improvisations may lead to change in product specifications in this data sheet, without any prior notice.