

## EXTINGUISHERS FOR METAL FIRES

### SPM-TEC (PRODUCT OVERVIEW)

Using the wrong extinguishing agent on a Class D fire may cause more damage than the fire itself. Other than the extreme threat that all metal fires pose, one common characteristic is that all of them react violently, often exploding, when they come in contact with water. So, what is the solution to a raging metal fire? The National Fire Prevention Association (NFPA), a panel of experts on fire safety and prevention, recommends Dry Powder extinguishing agents.

These extinguishing agents have a blanketing effect on the fire and smother the flames by absorbing the heat. SPM-TEC is a specially formulated powder agent based on a mixture of 3 metal chlorides: Sodium, Potassium, and Barium. Conforming to world-class manufacturing quality standards, it is ideal for fighting lighter metal fires in the range of 500-2000 degrees Celsius.



### ENGINEERING DRAWINGS

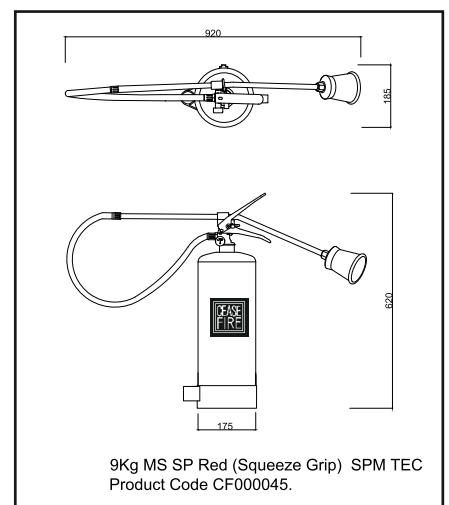
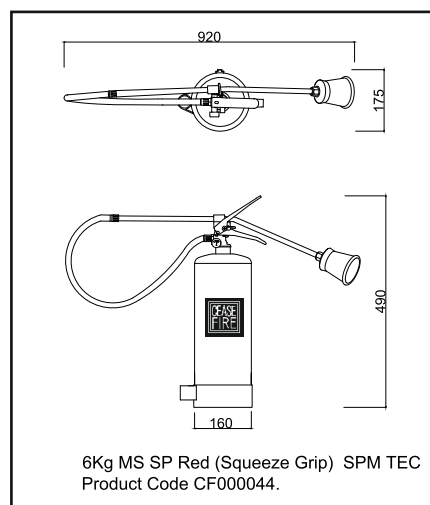
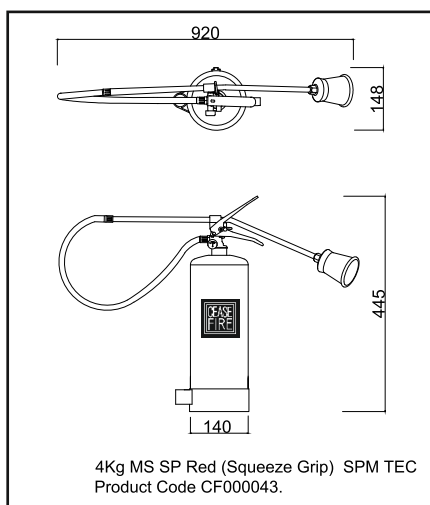



## TECHNICAL SPECIFICATIONS

Product Code	UOM	CF-000043	CF-000044	CF-000045
Description	—	Metal Fire Ext SPM Tec-4kg MS SP Red	Metal Fire Ext SPM Tec-6kg MS SP Red	Metal Fire Ext SPM Tec-9kg MS SP Red
Capacity of Agent	KG	4 ± 2%	6 ± 2%	9 ± 2%
Certification	—	PED	PED	PED
Diameter of Shell	MM	140	160	175
Total Height (approx.)	MM	440	485	615
MOC of Shell	—	Steel Cr2 (DC01)	Steel Cr2 (DC01)	Steel Cr2 (DC01)
Min. Wall Thickness	MM	1.2	1.4	1.4
Test Pressure	BAR	35	35	35
Anti-Corrosive Treatment	—	Outer surfaces were EP Powder coated having Thickness 50 Micron Min. RAL Shade 3000	Outer surfaces were EP Powder coated having Thickness 50 Micron Min. RAL Shade 3000	Outer surfaces were EP Powder coated having Thickness 50 Micron Min. RAL Shade 3000
Service Pressure	BAR	15	15	15
Type of Operating Mechanism	—	Squeeze Grip with NRV and Burst Disc.	Squeeze Grip with NRV and Burst Disc.	Squeeze Grip with NRV and Burst Disc.
Type of Pressure Gauge	—	Magnetic Bourdon Tube Type	Magnetic Bourdon Tube Type	Magnetic Bourdon Tube Type
Type of Dis. Fitting & Length	MM	EPDM Rubber Braided Hose Pipe with nozzle Length of Hose 730mm (Min.)	EPDM Rubber Braided Hose Pipe with nozzle Length of Hose 730 mm (Min.)	EPDM Rubber Braided Hose Pipe with nozzle Length of Hose 730 mm (Min.)
Throw	Meter	N/A	N/A	N/A
Min. Discharge Time	Sec.	15	16	18
Fire Rating	—	N/A	N/A	N/A
Operating Temperature Range	°C	From -30°C to +60°C	From -30°C to +60°C	From -30°C to +60°C

Product Code	UOM	CF-000043	CF-000044	CF-000045
Applicable to Type of Fire	—	Class D	Class D	Class D
Filled Weight Range*	KG	7.10 to 7.30	9.40 to 9.90	13.80 to 14.30
Packed Weight Range (approx)**	KG	8.53	11.1	16.1
Packed Size Length x Width x Height	MM	160 x 160 x 470	175 x 175 x 515	190 x 195 x 650
Product Warranty	YEAR	5	5	5

\*It includes Empty Extinguisher, Contents, Plastic Base, Hose / Horn and bracket.

\*\*It includes Empty Extinguisher, Packaging, Contents, Plastic Base, Hose / Horn and bracket.

## CERTIFICATIONS



## PRODUCT PICTURES



# EXTINGUISHERS FOR METAL FIRES

## SPM-PYRO (PRODUCT OVERVIEW)

Using the wrong extinguishing agent on a Class D fire may cause more damage than the fire itself. Other than the extreme threat that all metal fires pose, one common characteristic is that all of them react violently, often exploding, when they come in contact with water. So, what is the solution to a raging metal fire? The National Fire Prevention Association (NFPA), a panel of experts on fire safety and prevention, recommends Dry Powder extinguishing agents.

These extinguishing agents have a blanket effect on the fire and smother the flames by absorbing the heat. Metals such as plutonium and titanium can react and burn at temperatures of over 5000 °C. Ceasefire has a specialised firefighting agent, SPM PYRO, which is effective even at high temperatures.



## ENGINEERING DRAWINGS

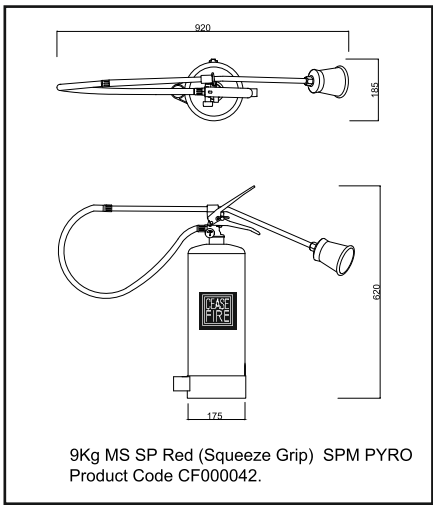
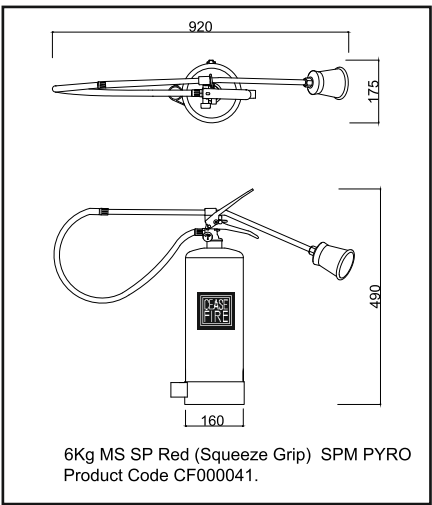
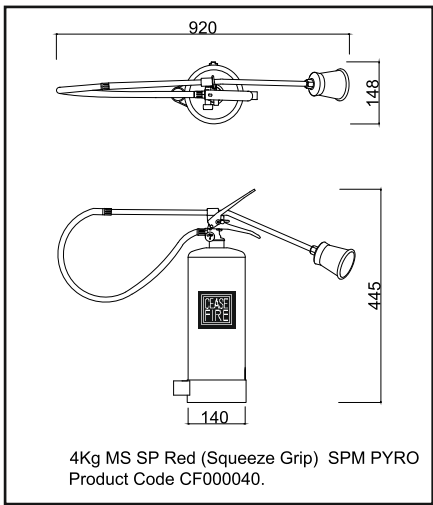



## TECHNICAL SPECIFICATIONS

Product Code	UOM	CF-000040	CF-000041	CF-000042
Description	—	Metal Fire Ext SPM PYRO-4kg MS SP Red	Metal Fire Ext SPM PYRO-6kg MS SP Red	Metal Fire Ext SPM PYRO-9kg MS SP Red
Capacity of Agent	KG	4 ± 2%	6 ± 2%	9 ± 2%
Certification	—	PED	PED	PED
Diameter of Shell	MM	140	160	175
Total Height (approx.)	MM	440	485	615
MOC of Shell	—	Steel Cr2 (DC01)	Steel Cr2 (DC01)	Steel Cr2 (DC01)
Min. Wall Thickness	MM	1.2	1.4	1.4
Test Pressure	BAR	35	35	35
Anti-Corrosive Treatment	—	Outer surfaces were EP Powder coated having Thickness 50 Micron Min. RAL Shade 3000	Outer surfaces were EP Powder coated having Thickness 50 Micron Min. RAL Shade 3000	Outer surfaces were EP Powder coated having Thickness 50 Micron Min. RAL Shade 3000
Service Pressure	BAR	15	15	15
Type of Operating Mechanism	—	Squeeze Grip with NRV and Burst Disc.	Squeeze Grip with NRV and Burst Disc.	Squeeze Grip with NRV and Burst Disc.
Type of Pressure Gauge	—	Magnetic Bourdon Tube Type	Magnetic Bourdon Tube Type	Magnetic Bourdon Tube Type
Type of Dis. Fitting & Length	MM	EPDM Rubber Braided Hose Pipe with nozzle Length of Hose 730mm (Min.)	EPDM Rubber Braided Hose Pipe with nozzle Length of Hose 730 mm (Min.)	EPDM Rubber Braided Hose Pipe with nozzle Length of Hose 730 mm (Min.)
Throw	Meter	N/A	N/A	N/A
Min. Discharge Time	Sec.	15	16	18
Fire Rating	—	N/A	N/A	N/A
Operating Temperature Range	°C	From -30°C to +60°C	From -30°C to +60°C	From -30°C to +60°C

Product Code	UOM	CF-000040	CF-000041	CF-000042
Applicable to Type of Fire	—	Class D	Class D	Class D
Filled Weight Range*	KG	7.10 to 7.30	9.40 to 9.90	13.80 to 14.30
Packed Weight Range (approx)**	KG	8.53	11.1	15.53
Packed Size Length x Width x Height	MM	160 x 160 x 470	175 x 175 x 515	190 x 195 x 650
Product Warranty	YEAR	5	5	5

\*It includes Empty Extinguisher, Contents, Plastic Base, Hose / Horn and bracket.

\*\*It includes Empty Extinguisher, Packaging, Contents, Plastic Base, Hose / Horn and bracket.

## CERTIFICATIONS



## PRODUCT PICTURES



\*v1' Published Date is 31-07-2022.

\*\*Regular R&D and product improvisations may lead to change in product specifications in this data sheet, without any prior notice.

# CEASEFIRE INDUSTRIES UK LIMITED

Call us at: 0-113-868-6666, 0-126-891-9999

[www.ceasefire.co.uk](http://www.ceasefire.co.uk)