

DATA SHEET

NEMA BELL HOUSING AND FLEXIBLE COUPLERS



**Bell Housing
Models:**

76215.15FR, 76256.15FR, 76286.15FR

**Flexible Coupling
Models:**

8382, 8383, 8388

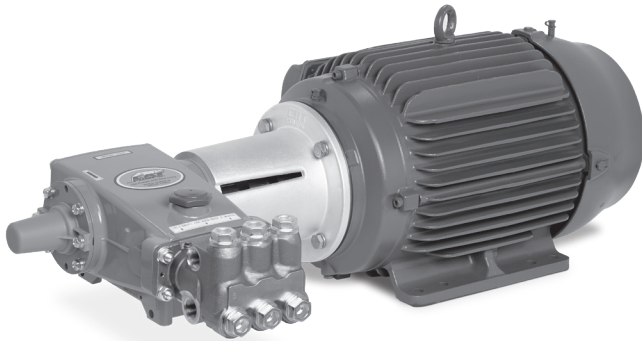

Bell housing and flexible coupling assembly shown with Model 660 and electric motor. Pump and motor sold separately.

FEATURES

- Eliminates belt selection, sizing and adjusting.
- Compact direct mounting feature reduces space required for belts or gearbox drive assemblies.
- Insulates against heat transfer.
- Special urethane flexible spyder designed for extended life with high temperature and high RPM.
- Complete assembled units from Cat Pumps includes pump, shaft protector, bell housing, flange adapter, flexible coupler, mounting hardware and motor.
- Designed to fit 15 and 18 frame pumps

PARTS LIST

8388 Flexible Coupler Assembly

| Pump Series | Motor Frame | Flex Coupler Assy | Shaft to Shaft | Torque Rating | Weight |
|--|-------------|-------------------|----------------|---------------|----------|
| 15 & 18FR | 213/215TC | 8388 | M30 to 1-3/8" | 150 ft/lbs | 6.28 lbs |
| PART NUMBERS | | | | | |
| Coupler Half, Motor – 1-3/8" Shaft, 5/16" Keyway | | | | | 996671 |
| Coupler Half, Pump – 30mm Shaft, 8mm Keyway | | | | | 996672 |
| Spyder (Purple) | | | | | 31544 |
| Key, Pump | | | | | 990036 |

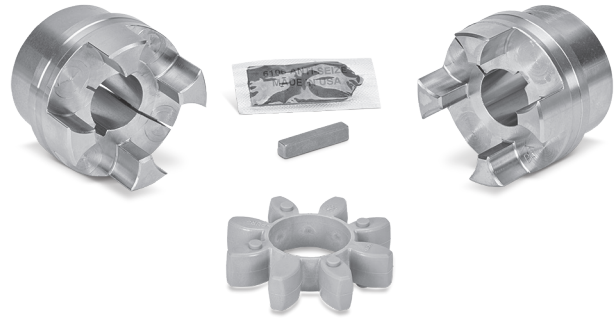

8382 Flexible Coupler Assembly

| Pump Series | Motor Frame | Flex Coupler Assy | Shaft to Shaft | Torque Rating | Weight |
|---|-------------|-------------------|----------------|---------------|----------|
| 15 & 18FR | 254/256TC | 8382 | M30 to 1-5/8" | 150 ft/lbs | 5.91 lbs |
| PART NUMBERS | | | | | |
| Coupler Half, Motor – 1-5/8" Shaft, 3/8" Keyway | | | | | 31543 |
| Coupler Half, Pump – 30mm Shaft, 8mm Keyway | | | | | 996672 |
| Spyder (Purple) | | | | | 31544 |
| Key, Pump | | | | | 990036 |

8383 Flexible Coupler Assembly

| Pump Series | Motor Frame | Flex Coupler Assy | Shaft to Shaft | Torque Rating | Weight |
|---|-------------|-------------------|----------------|---------------|----------|
| 15 & 18FR | 284/286TC | 8383 | M30 to 1-7/8" | 225 ft/lbs | 9.65 lbs |
| PART NUMBERS | | | | | |
| Coupler Half, Motor – 1-7/8" Shaft, 1/2" Keyway | | | | | 996693 |
| Coupler Half, Pump – 30mm Shaft, 8mm Keyway | | | | | 996692 |
| Spyder (Purple) | | | | | 996694 |
| Key, Pump | | | | | 990036 |

Bell Housing Assembly

| Pump Series | Models | NEMA Type | Bell Housing Assembly |
|-------------|----------------------|-----------|-----------------------|
| 15 & 18FR | All 15 & 18FR Models | 213/215TC | 76215.15FR |
| | | 254/256TC | 76256.15FR |
| | | 284/286TC | 76286.15FR |

76215.15FR & 76256.15FR include bell housing and mounting hardware.

76286.15FR includes bell housing, flange adapter and mounting hardware.



INSTALLATION

NEMA bell housing and flexible coupling

1. Separate the parts included in the bell housing assembly package and/or flexible coupler assembly package. Both assemblies offer separate kits to cover the various motor frames and pump models.
2. Remove bearing cover screws from either side of pump and discard screws. New screws supplied with bell housing assembly.
3. From the side where the screws have been removed, slide the small end of the bell housing over the pump shaft with the Cat Pumps logo facing up and positioned 22° from the top.
4. Use the new conical lock washers and screws as supplied in the bell housing assembly. Install eight (8) conical lock washers onto the eight (8) M8 screws. Apply Loctite® 242® to the threads of the screws and torque to specifications per chart.
5. Apply a light film of anti-seize lubricant to the pump shaft.
6. Install key into pump shaft.
7. Separate the pump M30 half of the flexible coupling and slide onto the pump shaft. Align inner face of coupler flush with end of crankshaft.
8. On the 213/215T and 254/256T frames, there is no flange adapter.
9. On the 284/286T frame, mount flange adapter with raised and finished surface away from motor. Apply Loctite® 242® to the threads of the four (4) 1/2" screws and torque to specifications per chart.
10. Apply a light film of anti-seize lubricant to the motor shaft.
11. Install motor key (as supplied with motor) into motor keyway.
12. Slide the 1-3/8", 1-5/8" or 1-7/8" half (motor side) of the flexible coupling with spyder onto the electric motor shaft.
13. Mount pump/bell housing/coupling half assembly to motor shaft with coupling half. Ensure the two halves are properly aligned.
14. Install four (4) lock washers onto four (4) 1/2" screws. Apply Loctite® 242® to the threads of the screws and thread into bell housing, torque to specifications per chart.
15. Through the opening at the top of the bell housing adjust coupler spacing so small knobs on spyder just barely contact each coupler half. Rotate coupling halves so the two (2) clamping screws are facing up. Use a 6mm Allen wrench and torque to specifications per chart.

NOTE: Flexible coupler halves should not contact each other. Ensure there is a small gap between coupler halves.

Loctite and 242 are registered trademarks of the Henkel Corporation.

Torque Specifications Chart

| Screw | Size | Tool | in/lbs | ft/lbs | Nm |
|-------------------------------------|------|-----------------|--------|--------|----|
| Bell Housing to Pump | M8 | M5 Allen | 115 | 9.6 | 13 |
| Bell Housing to Motor | 1/2" | 3/4" Hex Wrench | 300 | 25 | 34 |
| Adapter Plate to Motor (76286.15FR) | 1/2" | 3/8" Allen | 300 | 25 | 34 |
| Flexible Coupler Clamping Screws | M8 | M6 Allen | 300 | 25 | 34 |
| | M10 | M8 Allen | 600 | 50 | 68 |

DIMENSIONAL DRAWINGS

Bell Housing Assemblies

| Model | Motor Frame | A | Ø B | C (BC) | QTY | Ø D | E (BC) | QTY | Ø F |
|------------|-------------|-------|-------|--------|-----|-------|--------|-----|--------|
| 76215.15FR | 213/215TC | 5.92" | .565" | 7.25" | 4 | .335" | 4.13" | 8 | 8.50" |
| 76256.15FR | 254/256TC | 6.92" | .565" | 7.25" | 4 | .335" | 4.13" | 8 | 8.50" |
| 76286.15FR | 284/286TC | 7.87" | .565" | 9.00" | 4 | .335" | 4.13" | 8 | 10.50" |

76286.15FR

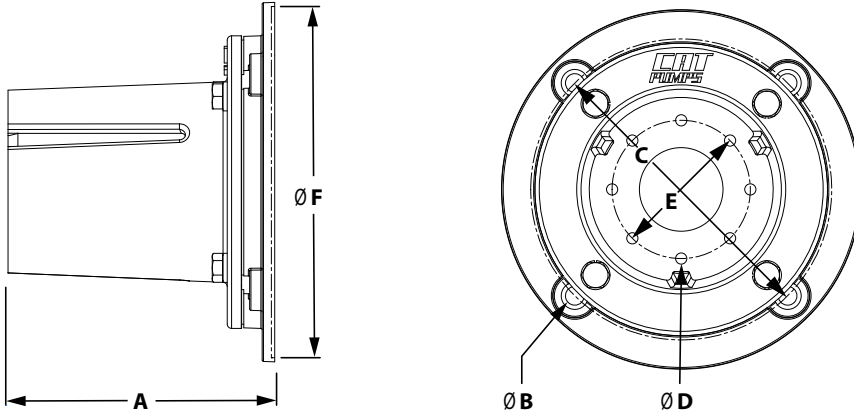

Flexible Coupling Assemblies

| Model | Ø A | B | C | D |
|-------|-------|-------|-------|-------|
| 8382 | 3.15" | 4.41" | .86" | 1.77" |
| 8383 | 3.15" | 4.41" | .86" | 1.77" |
| 8388 | 3.74" | 4.96" | 1.02" | 1.97" |

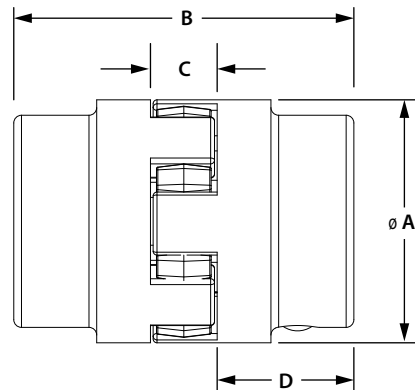
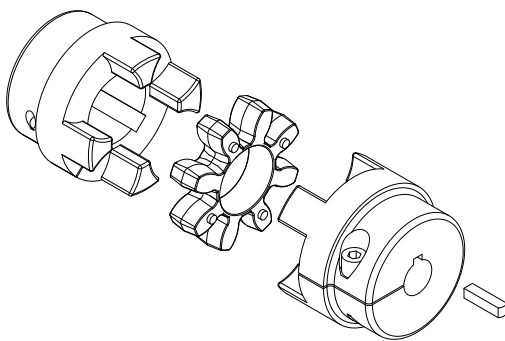

⚠ CAUTIONS AND WARNINGS

All High-Pressure Systems require a primary pressure regulating device (i.e. regulator, unloader) and a secondary pressure relief device (i.e. pop-off valve, relief valve). Failure to install such relief devices could result in personal injury or damage to pump or property. Cat Pumps does not assume any liability or responsibility for the operation of a customer's high-pressure system.

Read all CAUTIONS and WARNINGS before commencing service or operation of any high-pressure system. The CAUTIONS and WARNINGS are included in each service manual and with each Accessory Data Sheet. CAUTIONS and WARNINGS can also be viewed online at www.catpumps.com/cautions-warnings or can be requested directly from Cat Pumps.

WARRANTY

View the Limited Warranty on-line at www.catpumps.com/warranty.