

# DATA SHEET

## BELL HOUSING AND COUPLERS



**Hydraulic  
Bell Housing Models:** **76SAEC.25FR**  
**76SAEC.35FR**

**Flexible Coupling  
25 Frame Model:** **994303**

**Flexible Coupling  
35 Frame Models:** **994403, 997872, 999180,  
999206, 999368**

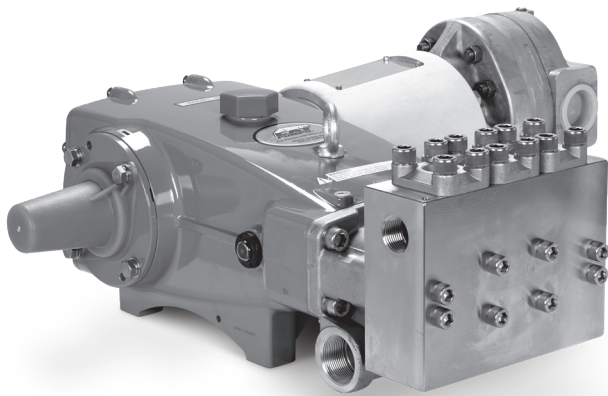

Model 3560 Shown  
(Bell housing and hydraulic motor sold separately)

### FEATURES

- Optimal alignment reduces side-loading for quiet, trouble-free operation
- Compact direct mounting reduces space requirement
- Bell housing cast from lightweight, high-strength aluminum alloy
- Ease of assembly reduces fabrication costs
- Rectangle opening in housings allow easy access to coupler set screws
- Available as a complete drive package for fast and convenient assembly

## INSTALLATION

### Hydraulic bell housing and flexible coupling for 25 frame pumps

**Note:** Ensure your pump has a production date of July 2020 or later. Prior to this July 2020 date the bell housing cannot be used.

1. Use an M13 hex wrench to remove four (4) screws from bearing cover. Remove bearing cover.
  2. Remove o-ring and oil seal. Inspect for wear or damage, replace as needed.
- Note:** Bearing does not need to be removed.
3. Place new bearing cover on flat surface with large opening facing up.
  4. Lubricate and install o-ring into groove of new bearing cover.
  5. Install oil seal into new bearing cover with spring side facing up.
  6. Slide new bearing cover over crankshaft. Align new bearing cover holes with crankcase hole pattern.
  7. Slide small diameter end of bell housing over the crankshaft with the opening at 45° facing forward or back. Line up holes.
  8. Slide lock washers over the eight (8) socket head cap screws as supplied.
  9. Apply Loctite®242® to each screw thread and insert into bell housing. Hand thread in.
  10. Use an M6 Allen wrench and torque to 115 in-lbs., 9.6 ft-lbs., 13 N-m.
  11. Lubricate and install key into slot of crankshaft.
  12. Slide 30mm end of pump coupler half over crankshaft.
  13. Slide spyder over crankshaft and fit into pump coupler half.
  14. Slide motor coupler half over crankshaft and fit onto spyder.
  15. Install hydraulic motor.
  16. Through the opening at the top of bell housing, adjust coupler spacing so small knobs on spyder just barely contact each coupler half. Rotate coupling halves so the two (2) clamping screws are facing up. Use an M6 allen wrench and torque to 300 in-lbs., 25 ft-lbs., or 34 N-m.
  17. Install flat cover over the opening on bell housing.
  18. Install four (4) No. 8-32 screws and tighten.

### Hydraulic bell housing and flexible coupling for 35 frame pumps

**Note:** Ensure your pump has a production date of June 2018 or later with quantity of four (4) M10 side cover screws (17 mm hex on screw head). Prior to this June 2018 date the bell housing cannot be used.

1. Remove existing bearing cover.
2. Ensure your pump has the 2-piece, 6-hole shim.
3. Before installing new bearing cover the following must be done:
  - a. With the bearing cover removed in step 1, please note that the bearing will stay on the crankshaft, but the bearing race will still be in the old bearing cover along with the oil seal and the o-ring.
  - b. Remove o-ring, oil seal and bearing race from old bearing cover. Discard old bearing cover.
  - c. Place new bearing cover on work surface with larger opening facing up.
  - d. Install bearing race into new bearing cover with the larger opening facing up.
  - e. Install oil seal into new bearing cover with small spring facing up.
  - f. Install o-ring onto groove of new bearing cover and lubricate.
  - g. Ensure that there is a gap between the top and bottom shim halves so the M10 screws will fit through.

4. Installing new bearing cover:
  - a. Slide new bearing cover over crankshaft and ensure bearing race fits over the bearing on the crankshaft. Align new bearing cover holes with crankcase hole pattern.
  - b. Slide small diameter end of bell housing over the crankshaft with the opening facing up. line up holes.
  - c. Slide lock washers over screws.
  - d. Apply Loctite®242® to screw threads and torque to 360 in-lbs., 30 ft-lbs or 41 N-m.
5. Installing flexible coupling:
  - a. Lubricate and install key into slot of crankshaft.
  - b. Slide 35mm end of pump coupler half over crankshaft.
  - c. Slide spyder over crankshaft and fit into pump coupler half.
  - d. Slide motor coupler half over crankshaft and fit onto spyder.
  - e. Install hydraulic motor.
  - f. Through the opening at the top of bell housing adjust coupler spacing so small knobs on spyder just barely contact each coupler half. Rotate coupling halves so the two (2) clamping screws are facing up. Use a M10 Allen wrench and torque to 360 in-lbs., 30 ft-lbs., or 41 N-m.
  - g. Install flat cover over opening on bell housing.
  - h. Install four (4) No. 8-32 screws and tighten.

Loctite and 242 are registered trademarks of the Henkel Corporation.



### Bell Housing Assemblies

PUMP SERIES	MODELS	SAE TYPE	BELL HOUSING ASSEMBLY
25FR Series	All 25FR Models	C2/C4	76SAEC.25FR
35FR Series	All 35FR Models	C2/C4	76SAEC.35FR

Bell housing assembly include mounting hardware, flat cover with screws and bearing cover.

#### SAE TYPE:

C2 = SAE "C" 2 Bolt, 5" Pilot

C4 = SAE "C" 4 Bolt, 5" Pilot

## Flexible Coupler Assemblies

PUMP SERIES	SAE TYPE	FLEX COUPLER ASSY	SHAFT TO SHAFT	TORQUE RATING
25FR	C2, C4	994303	30mm x 1 ¼"	188 ft-lbs
35FR	C2, C4	997872	35mm x 1 ¼"	350 ft-lbs
		999368	35mm x 1 ⅜"	350 ft-lbs
		994403	35mm x 1 ½"	350 ft-lbs
		999180	35mm x 1 ⅝"	350 ft-lbs
		999206	35mm x 1 ⅞"	350 ft-lbs

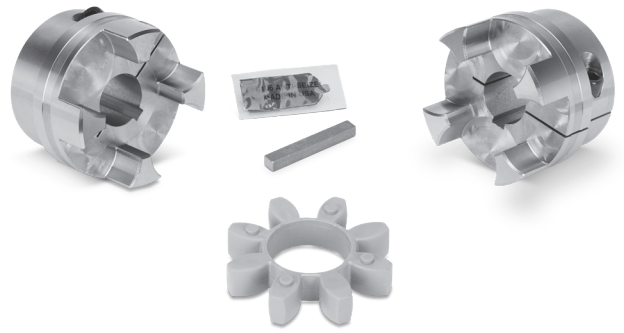

### SAE TYPE:

C2 = SAE "C" 2 Bolt, 5" Pilot

C4 = SAE "C" 4 Bolt, 5" Pilot

## Flexible Coupler Model Assemblies

	994303	997872	999368	994403	999180	999206
SAE Type	C	C	C	C	C	C
Motor Shaft Ø	1 ¼"	1 ¼"	1 ⅜"	1 ½"	1 ⅝"	1 ⅞"
Motor Shaft Key	⅝"	⅝"	⅝"	⅜"	⅜"	½"
Pump Shaft Ø	30mm	35mm	35mm	35mm	35mm	35mm
Pump Shaft Key	8mm	10mm	10mm	10mm	10mm	10mm
Diameter	3.14"	4.13"	4.13"	4.13"	4.13"	4.13"
Length	4.41"	5.52"	5.52"	5.52"	5.52"	5.52"
Spyder	994302	997633	997633	997633	997633	997633
(Color)	Light Green	Purple	Purple	Purple	Purple	Purple
Coupler Half, Motor	31898	996821	996816	996811	996814	996813
Coupler Half, Pump	996672	996818	996818	996818	996818	996818
Key, Pump	30067	34021	34021	34021	34021	34021

## Torque Specifications Chart

Screw	Size	Tool	in-lbs.	ft-lbs.	Nm.
Bell Housing, 25 Frame Screws	M8	6 mm allen	115	9.6	13
Flexible Coupler, 25 Frame Clamping Screws	M8	6 mm allen	300	250	34
Bell Housing, 35 Frame Screws	M10	8 mm allen	360	30	41
Flexible Coupler, 35 Frame Clamping Screws	M12	10mm allen	360	30	41

## Dimensional Drawing

	A	B
25FR	8.61	18.37
35FR	9.88	21.38

**Note:** Overall length will vary pending hydraulic motor selection

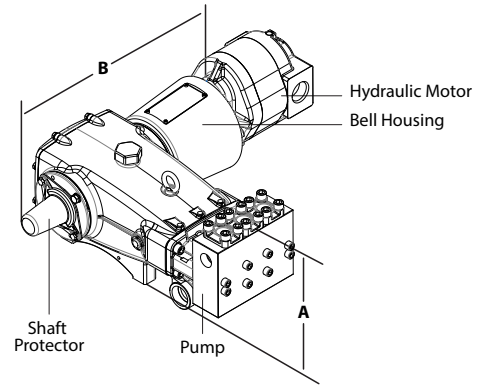

Model 3560 Shown

## Flexible Coupling Assembly

Model	A	B	C	D
994303	3.14 (79.75)	4.41 (112.00)	0.86 (21.84)	1.77 (44.95)
997872	4.13 (104.90)	5.52 (140.20)	1.02 (25.90)	2.20 (55.90)
999368	4.13 (104.90)	5.52 (140.20)	1.02 (25.90)	2.20 (55.90)
994403	4.13 (104.90)	5.52 (140.20)	1.02 (25.90)	2.20 (55.90)
999180	4.13 (104.90)	5.52 (140.20)	1.02 (25.90)	2.20 (55.90)
999206	4.13 (104.90)	5.52 (140.20)	1.02 (25.90)	2.20 (55.90)

## DIMENSIONAL

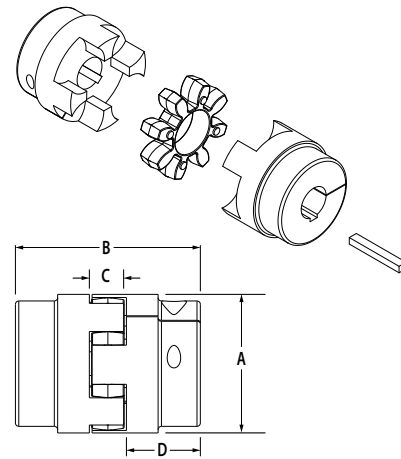

### ⚠ CAUTIONS AND WARNINGS

All high-pressure systems require a primary pressure regulating device (i.e. regulator, unloader) and a secondary pressure relief device (i.e. pop-off valve, relief valve). Failure to install such relief devices could result in personal injury or damage to pump or property. Cat Pumps does not assume any liability or responsibility for the operation of a customer's high-pressure system.

Read all CAUTIONS and WARNINGS before commencing service or operation of any high-pressure system. The CAUTIONS and WARNINGS are included in each Service Manual and with each Accessory Data sheet. CAUTIONS and WARNINGS can also be viewed online at [www.catpumps.com/dynamic-literature/cautions-and-warnings](http://www.catpumps.com/dynamic-literature/cautions-and-warnings) or can be requested directly from Cat Pumps.

### WARRANTY

View the Limited Warranty on-line at [www.catpumps.com/literature/cat-pumps-limited-warranty](http://www.catpumps.com/literature/cat-pumps-limited-warranty)