

# 68 Frame Block-Style Stainless Steel Plunger Pump

**Standard  
Models**

**6831**

**Flushed  
Models**

**6831K**

## FEATURES

### Superior Design

- Triplex plunger design provides smoother liquid flow.
- Oil bath crankcase assures optimum lubrication.
- Close tolerance concentricity of the ceramic plunger maximizes seal life.
- **Standard Models:** Lo-Pressure Seals and V-Packings are completely lubricated and cooled by the liquid being pumped.
- **K Models:** Special Flushed Inlet Manifold permits flush for added cooling with high temperature liquids and lubrication with low lubricity liquids.

### Quality Materials

- Precision design 316 stainless steel valves and seats are hardened and polished for ultimate seating and extended valve life.
- 316 SSL block-style manifolds for strength and corrosion resistance.
- Special concentric, high-density, polished, solid ceramic plungers provide a true wear surface and extended seal life.
- Specially formulated, CAT PUMP exclusive, V-Packings offer unmatched performance and seal life.
- Die cast aluminum crankcase provides high strength, minimum weight and precision tolerance control.
- Optional Cast Iron crankcase for hazardous environments.
- Chrome-moly crankshaft gives unmatched strength and surface hardness.
- Oversized crankshaft bearings mean longer bearing life.

### Easy Maintenance

- Wet-end is easily serviced without entering crankcase, requiring less time and effort.
- Inlet and discharge valve assemblies interchange for easier maintenance without disturbing piping.
- Preset packings mean no packing gland adjustment is necessary, reducing maintenance costs.

### **⚠ WARNING**

All systems require both a primary pressure regulating device (i.e., regulator, unloader) and a secondary pressure safety relief device (i.e., pop-off valve, safety valve). Failure to install such relief devices could result in personal injury or damage to the pump or to system components. CAT PUMPS does not assume any liability or responsibility for the operation of a customer's high pressure system.

## SPECIFICATIONS

	U.S. Measure	Metric Measure
Flow .....	40 GPM	(151 L/M)
Pressure Range.....	100 to 2300 PSI	(7 to 160 BAR)
Inlet Pressure Range* .....	Flooded to 50 PSI	(Flooded to 3.5 BAR)
Max. RPM.....	625 RPM	(625 RPM)
Bore.....	1.575"	(40 mm)
Stroke.....	2.579"	(65.5 mm)
Crankcase Capacity.....	10 Qts.	(9.46 L)
Maximum Liquid Temperature .....	140°F	(60°C)
Above 130F call CAT PUMPS for inlet conditions and elastomer recommendations.		
Inlet Ports (2) .....	1-1/2" NPTF	(1-1/2" NPTF)
Flushing Ports (2)* .....	1/2" NPTF	(1/2" NPTF)
Discharge Ports (2).....	1" NPTF	(1" NPTF)
Shaft Diameter .....	1.772"	(45 mm)
Weight.....	355 lbs.	(161 kg)
Dimensions.....	29.5 x 24.33 x 12.00"	(750 x 618 x 305 mm)

\* K Models: Special Flushed Inlet Manifold permits external flush for added cooling with high temperature liquids and lubrication with low lubricity liquids.

## ELECTRIC HORSEPOWER REQUIREMENTS

FLOW		PRESSURE				RPM
		PSI 1000	PSI 1500	PSI 2000	PSI 2300	
U.S. GPM	L/M	BAR 70	BAR 105	BAR 140	BAR 160	
40	151	27.4	41.1	54.8	63.0	625
30	114	20.6	30.9	41.1	47.3	470
25	95	17.2	25.7	34.3	39.4	391
20	76	13.7	20.5	27.5	31.5	331

**DETERMINING THE PUMP R.P.M.**       $\frac{\text{Rated G.P.M.}}{\text{Rated R.P.M.}}$       =       $\frac{\text{"Desired" G.P.M.}}{\text{"Desired" R.P.M.}}$

**DETERMINING THE REQUIRED H.P.**       $\frac{\text{GPM} \times \text{PSI}}{1460}$       =      Electric Brake H. P. Required

**DETERMINING MOTOR PULLEY SIZE**       $\frac{\text{Motor Pulley O.D.}}{\text{Pump R.P.M.}}$       =       $\frac{\text{Pump Pulley O.D.}}{\text{Motor R.P.M.}}$

See complete Drive Packages [Incls: Pulleys, Belts, Hubs, Key] Tech Bulletin 003.  
Refer to pump **Service Manual** for repair procedure, additional technical information and **pump warranty**.

*"Customer confidence is our greatest asset"*

# PARTS LIST

ITEM	PART NUMBER		DESCRIPTION	QTY		
	<b>6831</b>	<b>MATL</b>	<b>6831K</b>	<b>MATL</b>		
2	43048	STL	43048	STL	Key (M14x9x90)	1
5	89728	S	89728	S	Screw, HH (M10x40)	8
6	15847	S	15847	S	Lockwasher (M10)	8
7	19934	SS	19934	SS	Washer, Flat (M10)	8
8	29443	AL	29443	AL	Cover, Bearing, Outer	2
10	29444	NBR	29444	NBR	O-Ring, Cover Bearing - 70D	2
11	11443	NBR	11443	NBR	Seal, Oil, Crankshaft - 70D	2
12	43642	S	43642	S	Washer, Shim (M120x0.3)	0-2
	126594	STCP R	126594	STCP R	Washer, Shim (M120x0.3)	0-2
13	126595	STCP R	126595	STCP R	Washer, Shim (M120x0.5)	0-2
15	29441	STL	29441	STL	Bearing, Roller	2
16	29442	STL	29442	STL	Cover Bearing, Inner	2
17	29444	NBR	29444	NBR	O-Ring, Cover Bearing - 70D	2
20	126612	BBHS	126612	BBHS	Rod, Connecting Assembly (Incls: 21, 22)	3
21	126560	STCP R	126560	STCP R	Washer, Locking	3
22	126593	STCP R	126593	STCP R	Shim, Washer (M10.5x1.5)	6
25	29440	FCM	29440	FCM	Crankshaft, Dual Shaft	1
31	828710	—	828710	—	Protector, Oil Cap	1
32	43211	ABS	43211	ABS	Cap, Oil Filler	1
33	14177	NBR	14177	NBR	O-Ring, Filler Cap - 70D	1
34	126743	STCP R	126743	STCP R	Bolt, Eye (M12) (For Lifting Pump Only)	1
38	11338	NBR	11338	NBR	O-Ring, Dip Stick - 70D	1
39	27769	ABS	27769	ABS	Dipstick	1
40	89627	S	89627	S	Screw, HH (M10x30)	8
41	15847	S	15847	S	Lockwasher (M10)	8
42	19934	SS	19934	SS	Washer, Flat (M10)	8
48	25625	STCP	25625	STCP	Plug, Drain (1/4"x19BSP)	1
49	23170	NBR	23170	NBR	O-Ring, Drain Plug - 70D	1
50	29438	AL	29438	AL	Cover, Rear	1
51	29439	NBR	29439	NBR	Gasket, Rear Cover	1
53	45303	AL	45303	AL	Crankcase (Incls: 34, 54)	1
54	43282	S	43282	S	Pin, Guide	2
64	29481	CM	29481	CM	Pin, Crosshead	3
65	48735	SSZZ	48735	SSZZ	Rod, Plunger Assembly	3
69	126588	STCP R	126588	STCP R	Washer, Oil Seal	3
70	29454	NBR	29454	NBR	Seal, Oil, Crankcase - 80D	3
75	43865	S	43865	S	Slinger, Barrier	3
88	45676	S	45676	S	Washer, Keyhole (M16)	3
90	43921	CC	43921	CC	Plunger (M40x145)	3
95	89778	SS	89778	SS	Stud, Plunger Retainer (M10x135)	3
96	20189	PTFE	20189	PTFE	Back-up-Ring, Plunger Retainer	3
97	11345	NBR	11345	NBR	O-Ring, Plunger Retainer - 70D	3
	11375	FPM	11375	FPM	O-Ring, Plunger Retainer - 70D	3
98	44085	SS	44085	SS	Gasket, Plunger Retainer	3
99	44084	SS	44084	SS	Retainer, Plunger (M10)	3
100	703084	D	703084	D	Retainer, Seal	3
106	44113	NBR	44113	NBR	Seal, LPS, w/SS-Spg	3
	44740	FPM	44740	FPM	Seal, LPS, w/SS-Spg	3
108	45381	SS	45381	SS	Spacer, LPS	3
110	701321	SSL	—	—	Manifold Inlet, Block-Style	1
	—	—	701322	SSL	Manifold Inlet, Block-Style, Flushed	1
111	701116	SS	701116	SS	Plug, Inlet Manifold (1-1/2" NPT)	1
112	701632	NBR	701632	NBR	O-Ring, Spacer	6
	701328	FPM	701328	FPM	O-Ring, Spacer	6
113	701329	PTFE	701329	PTFE	Back-up-Ring, Spacer	6
114	701327	SS	701327	SS	Spacer, Inlet	3
117	89694	S	89694	S	Screw, HSH (M16x110)	6
118	701077	SS	—	—	Plug (1/4" NPT)	3
126	45367	SS	45367	SS	Adapter, Female	3
127	44609	STG*	44609	STG*	V-Packing	6
	44741	SFG	44741	SFG	V-Packing	6
128	45368	SS	45368	SS	Adapter, Male	3
155	48860	NBR	48860	NBR	O-Ring, V-Packing Spacer, Inner - 90D	3
	20137	FPM	20137	FPM	O-Ring, V-Packing Spacer, Inner - 70D	3
156	48362	D	48362	D	Back-up-Ring, V-Packing Spacer	6
157	45369	SS	45369	SS	Spacer, V-Packing	3
159	48860	NBR	48860	NBR	O-Ring, V-Packing Spacer, Outer - 90D	3
	20137	FPM	20137	FPM	O-Ring, V-Packing Spacer, Outer - 70D	3
160	44756	SS	44756	SS	Pin, Guide	2
162	48363	D	48363	D	Back-up-Ring, Seat	6
163	26142	NBR	26142	NBR	O-Ring, Seat - 80D	6
	14330	FPM	14330	FPM	O-Ring, Seat	6
164	44612	SS	44612	SS	Seat	6
166	44108	SS	44108	SS	Valve	6
167	44109	SS	44109	SS	Spring	6
168	44728	PVDF	44728	PVDF	Retainer, Spring	6
170	44729	SS	44729	SS	Washer, Retainer	6
171	44644	SS	44644	SS	Spring, Coil	6
172	89827	NBR	89827	NBR	O-Ring, Valve Plug - 90D	6
	11747	FPM	11747	FPM	O-Ring, Valve Plug - 90D	6
173	48364	D	48364	D	Back-up-Ring, Valve Plug	6
174	701432	SS	701432	SS	Plug, Valve	6
175	87951	S	87951	S	Screw, HSH (M10x30)	36
185	701431	SSL	701431	SSL	Manifold, Discharge, Block-Style	1
188	701279	S	701279	S	Screw, HSH (M12x100), Lower	4
193	89694	S	89694	S	Screw, HSH (M16x110), Upper	8
250	29445	AL	29445	AL	Protector, Shaft	1
255	33243	STZP	33243	STZP	Kit, Mount (Included w/Pump)	2
259	29477	STZP	29477	STZP	Rail, Box (Included w/Pump)	2
275	990014	STL	990014	STL	Hub, "B", (M45), (Keyway M14x9x90) [See Drive Package, Tech Bulletin 003]	1
283	34314	—	34314	—	Kit, Oil Drain (3/8" x 48")	1
290	6124	—	6124	—	Gasket, Liquid (3 oz.)	1

# EXPLODED VIEW

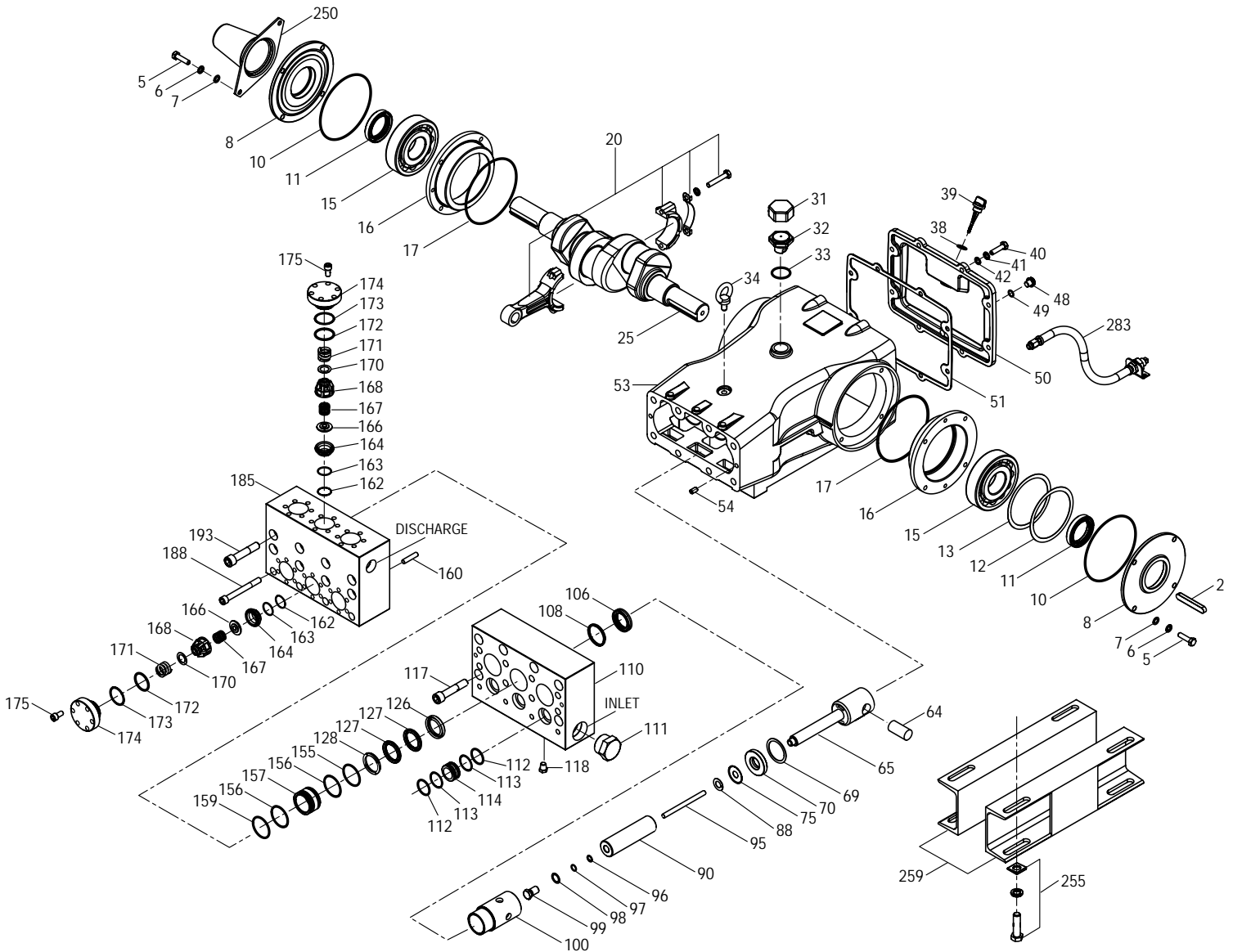

Models  
 Standard - 6831  
 Flushed - 6831K  
 February 2009

	<b>6831</b>	<b>MATL</b>	<b>6831K</b>	<b>MATL</b>		
299	<b>910003</b>	<b>SSL</b>	—	—	Head, Complete, Block-Style	1
—	—	—	<b>910004</b>	<b>SSL</b>	Head, Complete, Block-Style, Flushed	1
300	701647	NBR*	701647	NBR*	Kit, Seal (Incls: 97,106,112,113,127,155,156,159)	1
—	33708	FPM	33708	FPM	Kit, Seal (Incls: 97,106,112,113,127,155,156,159)	1
310	34017	NBR	34017	NBR	Kit, Valve (Incls: 162,163,164,166,167,168,170,172,173)	2
—	31955	FPM	31955	FPM	Kit, Valve (Incls: 162,163,164,166,167,168,170,172,173)	2
—	819010	F	819010	F	Assy, Crankcase, CAST IRON Conversion	1
370	—	—	<b>990663</b>	—	Assembly, Flushing, 5 gal., 115V, 1.1 Amp, 1/2" NPT	1
390	714500	SS	714500	SS	C.A.T. (Inlet pressure stabilizer for RO and boosted inlet applications)	1
391	714506	SS	714506	SS	Adapter (2 per C.A.T.) (See Data Sheet for complete selection)	2
392	701828	SS	701828	SS	Elbow Assy used with Adapter Assy 714506	1
—	6575	—	6575	—	Plunger Pump Service DVD	1
—	6105	—	6105	—	Oil, Twin Pack (Two 2.5 gal.) ISO-68 Hydraulic	1
—	6119	—	6119	—	(Fill to specified crankcase capacity prior to start-up) Lubricant, Antiseize (1 oz.)	1

**Bold print part numbers are unique to a particular pump model. Italics are optional items.** R Components comply with RoHS Directive.

\*Review individual parts in each kit for material code identification.

See Tech Bulletin 002, 003, 024, 036, 074, 077, 083, 084, 095 and 105 for additional information.

C.A.T. highly recommended for pressurized inlet, R.O. and industrial applications.

MATERIAL CODES (Not Part of Part Number): ABS=ABS Plastic AL=Aluminum BBHS=Brass/High Strength CC=Ceramic CM=Chrome-Moly  
 D=Delryn F=Cast Iron FCM=Forged Chrome-moly FPM=Fluorocarbon NBR=Medium Nitrile (Buna-N) PTFE=Pure Polytetrafluoroethylene PVDF=Polyvinylidene Fluoride  
 S=304SS SS=316SS SSL=316SS/Low Carbon SSZZ=316SS/Zamak SFG=Special Blend FPM STG=Special Blend PTFE White STL=Steel  
 STCP=Steel/Chrome Plated STZP=Steel/Zinc Plated

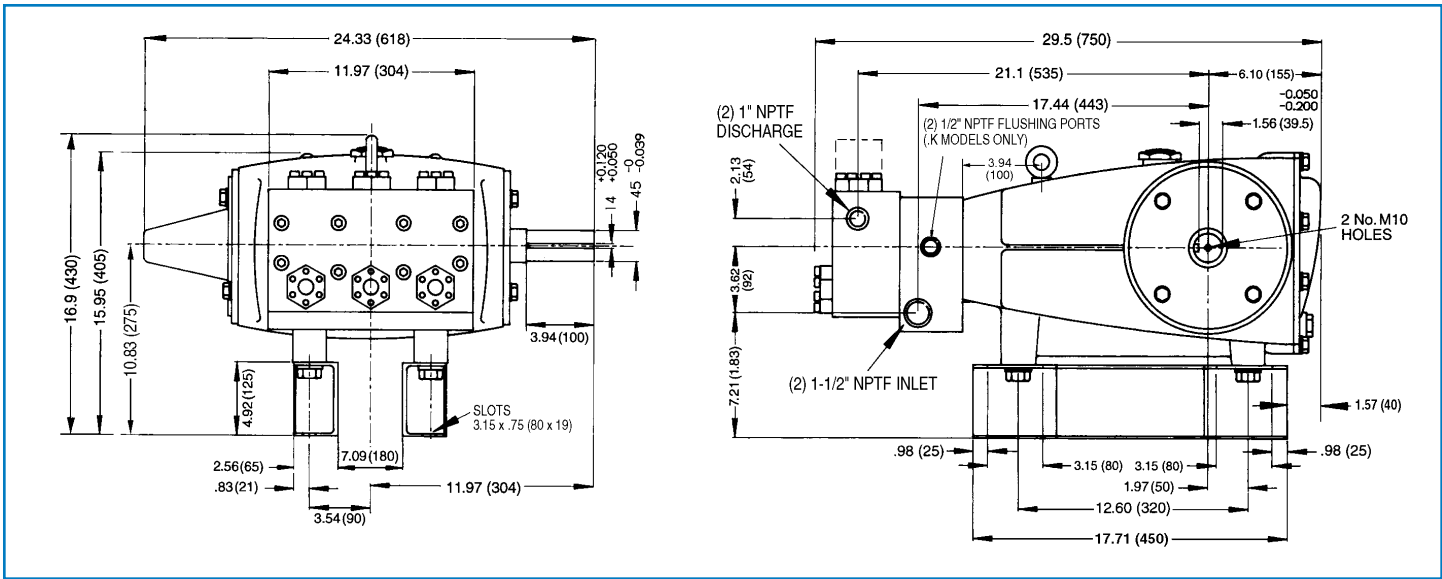

Models 6831, 6831K

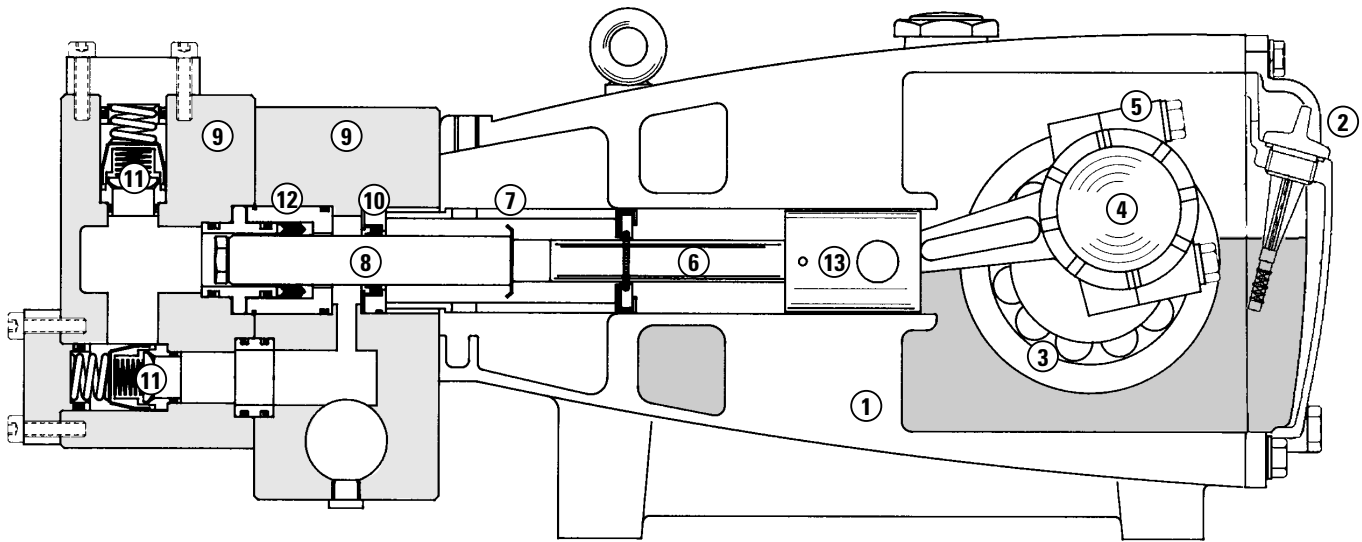

- 1 Die cast aluminum **crankcase** means high strength, light weight, and excellent tolerance control.
- 2 **Dipstick** offers top access for easy oil level check.
- 3 Oversized crankshaft **bearings** provide extended bearing life and pump performance.
- 4 Chrome-moly **crankshaft** provides unmatched strength and surface hardness for long life.
- 5 Matched oversized high strength **connecting rods** are noted for superior tensile strength and bearing quality.
- 6 Special stainless steel high strength **plunger rods** for high load bearing and longevity.
- 7 The stainless steel **barrier slinger** provides back-up protection for the crankcase seal, keeping pumped liquids out of the crankcase.
- 8 Special concentric, high density, polished, solid ceramic **plungers** provide a true wear surface and extended seal life.
- 9 **Manifolds** are 316 SSL block-style for long-term, continuous-duty and corrosion resistance.
- 10 **Standard Models:** Lo-Pressure Seals and V-Packings are completely lubricated and cooled by the liquids being pumped.
- 11 Special **Flushed Inlet Manifold** permits external flush for added cooling with high temperature liquids and lubrication with low lubricity liquids.
- 12 316 stainless steel **valves, seats and springs** provide corrosion-resistance, ultimate seating and extended life.
- 13 Specially formulated, CAT PUMP exclusive, **V-Packings** offer unmatched performance and seal life.
- 14 **Crossheads** are 360° supported for uncompromising alignment.

## World Headquarters

CAT PUMPS

1681 - 94th Lane N.E. Minneapolis, MN 55449-4324

Phone (763) 780-5440 — FAX (763) 780-2958

e-mail: techsupport@catpumps.com

www.catpumps.com

## International Inquiries

FAX (763) 785-4329

e-mail: intlsales@catpumps.com



The Pumps with Nine Lives

## CAT PUMPS (U.K.) LTD.

1 Fleet Business Park, Sandy Lane, Church Crookham

FLEET, Hampshire, GU52 8BF, England

Phone Fleet 44 1252-622031 — Fax 44 1252-626655

e-mail: sales@catpumps.co.uk www.catpumps.co.uk

## N.V. CAT PUMPS INTERNATIONAL S.A.

Heiveldekens 6A, B-2550 Kontich, Belgium

Phone 32-3-450.71.50 — Fax 32-3-450.71.51

e-mail: cpi@catpumps.be www.catpumps.be

## CAT PUMPS DEUTSCHLAND GmbH

Buchwiese 2, D-65510 Idstein, Germany

Phone 49 6126-9303 0 — Fax 49 6126-9303 33

e-mail: catpumps@t-online.de www.catpumps.de