

3CP Plunger Pump

Standard Models 3CP1120, 3CP1130
3CP1140

Gearbox Model 3CP1120G

FEATURES

Superior Design

- Triplex plunger design delivers smoother liquid flow.
- Hi-Pressure Seals are completely lubricated and cooled by the liquid being pumped.
- Inlet and discharge valve assemblies interchange for easier maintenance.
- Lubricated Lo-Pressure Seal provides double protection against external leakage.
- Oil bath crankcase assures optimum lubrication.
- Close tolerance concentricity of the ceramic plunger maximizes seal life.

Quality Materials

- Precision design 304 stainless steel valves and seats are hardened and polished for ultimate seating and extended valve life.
- Forged brass manifolds for strength and corrosion resistance.
- Special concentric, high-density, polished, solid ceramic plungers provide a true wear surface and extended seal life.
- Specially formulated, CAT PUMP exclusive, Hi-Pressure Seals offer unmatched performance and seal life.
- Die cast aluminum crankcase provides high strength, minimum weight and precision tolerance control.
- Chrome-moly crankshaft gives unmatched strength and surface hardness.
- Oversized crankshaft bearings with greater capacity mean longer bearing life.

Easy Maintenance

- Wet-end is easily serviced without entering crankcase, requiring less time and effort.
- Valve assemblies are accessible without disturbing piping, for quick service.
- Preset packings mean no packing gland adjustment is necessary, reducing maintenance costs.

SPECIFICATIONS

U.S. Measure Metric Measure

MODEL 3CP1120

Flow4.2 GPM (16 L/M)
Pressure Range100 to 2200 PSI (7 to 155 BAR)
RPM1725 RPM (1725 RPM)
Stroke0.500" (12.7 mm)

MODEL 3CP1120G — GEARBOX (2.55 : 1 RATIO)

Flow3.5 GPM (13.2 L/M)
Pressure Range100 to 2200 PSI (7 to 155 BAR)
RPM1420 RPM (1420 RPM)
Engine RPM3600 RPM (3600 RPM)
Stroke0.512" (12.7 mm)

MODEL 3CP1130

Flow2.4 GPM (9 L/M)
Pressure Range100 to 2200 PSI (7 to 155 BAR)
RPM1725 RPM (1725 RPM)
Stroke0.276" (7 mm)

MODEL 3CP1140

Flow3.6 GPM (13.6 L/M)
Pressure Range100 to 2200 PSI (7 to 155 BAR)
RPM1725 RPM (1725 RPM)
Stroke0.433" (11 mm)

COMMON SPECIFICATIONS

Inlet Pressure RangeFlooded to 70 PSI (Flooded to 4.9 BAR)
Bore0.709" (18 mm)
Crankcase Capacity11.8 oz. (0.35 L)
Maximum Liquid Temperature160°F (71°C)
Above 130°F call CAT PUMPS for inlet conditions and elastomer recommendations.
Inlet Ports (2)1/2" NPTF (1/2" NPTF)
Discharge Ports (2)3/8" NPTF (3/8" NPTF)
Pulley MountingEither Side (Either Side)
Shaft Diameter0.650" (16.5 mm)
Weight14.84 lbs. (6.7 kg)
Dimensions9.1 x 8.78 x 5.47" (231 x 223 x 139 mm)

ELECTRIC HORSEPOWER REQUIREMENTS

MODEL	FLOW		PRESSURE				MOTOR PULLEY SIZE	
	U.S. GPM	L/M	PSI 1200	PSI 1500	PSI 2000	PSI 2200	RPM	Pulley O.D.
3CP1120	4.2	16	3.5	4.3	5.8	6.3	1725	5.0
	3.5	13.2	2.9	3.6	4.8	5.3	1531	4.4
	3.0	11.4	2.5	3.1	4.2	4.5	1313	3.8
3CP1130	2.4	9	1.9	2.4	3.2	3.6	1725	Direct Drive
3CP1140	3.6	13.6	3.0	3.7	5.0	5.4	1725	Direct Drive
3CP1120G	3.5	13.2	2.9	3.6	4.8	5.3	1420	Gearbox

DETERMINING THE PUMP R.P.M. $\frac{\text{Rated G.P.M.}}{\text{Rated R.P.M.}}$ = "Desired" G.P.M. / "Desired" R.P.M.

DETERMINING THE REQUIRED H.P. $\frac{\text{GPM} \times \text{PSI}}{1460}$ = Electric Brake H. P. Required

DETERMINING MOTOR PULLEY SIZE $\frac{\text{Motor Pulley O.D.}}{\text{Pump R.P.M.}}$ = $\frac{\text{Pump Pulley O.D.}}{\text{Motor R.P.M.}}$

See complete Drive Packages [Incls: Pulleys, Belts, Hubs, Key] Tech Bulletin 003.
Refer to pump **Service Manual** for repair procedure, additional technical information and **pump warranty**.

⚠ WARNING

All systems require both a primary pressure regulating device (i.e., regulator, unloader) and a secondary pressure safety relief device (i.e., pop-off valve, safety valve). Failure to install such relief devices could result in personal injury or damage to the pump or to system components. CAT PUMPS does not assume any liability or responsibility for the operation of a customer's high pressure system.

"Customer confidence is our greatest asset"

PARTS LIST

ITEM	P/N	MATL	DESCRIPTION	QTY
2	30047	STL	Key (M5x5x24)	1
5	92519	STZP	Screw, HHC Sems (M6x16)	8
	125824	STCP R	Screw, HHC Sems (M6x16)	8
8	46901	AL	Cover, Bearing	2
	48259	AL	Cover, Blind - 3CP1120G	1
10	14028	NBR	O-Ring, Bearing Cover - 70D	2
11	43222	NBR	Seal, Oil, Crankshaft - 70D	1/2
15	14480	STL	Bearing, Ball	2
20	48730	TNM	Rod, Connecting, Assembly [5/01]	3
25	46927	FCM	Crankshaft, Dual End - 3CP1120 (M12.7)	1
	46994	FCM	Crankshaft, Dual End - 3CP1130 (M7)	1
	46991	FCM	Crankshaft, Dual End - 3CP1140 (M11)	1
	48257	FCM	Crankshaft, Single End - 3CP1120G (M12.7)	1
32	46798	RTP	Cap, Oil Filler	1
33	14179	NBR	O-Ring, Oil Filler Cap - 70D	1
37	92241	—	Gauge, Oil, Bubble w/Gasket	1
38	44428	NBR	Gasket, Flat, Oil Gauge - 80D	1
40	92519	STZP	Screw, HHC Sems (M6x16)	4
	125824	STCP R	Screw, HHC Sems (M6x16)	4
48	25625	STCP	Plug, Drain (1/4"x19BSP)	1
49	23170	NBR	O-Ring, Drain Plug - 70D	1
50	46939	AL	Cover, Rear	1
51	14041	NBR	O-Ring, Rear Cover - 70D	1
53	48644	AL	Crankcase	1
64	46615	CM	Pin, Crosshead	3
65	48459	BBNP	Rod, Plunger	3
70	46839	NBR	Seal, Oil, Crankcase	3
75	43900	S	Slinger, Barrier	3
88	45697	S	Washer, Keyhole	3
90	46976	CC	Plunger (M18x43)	3
98	46730	NBR	Washer, Seal - 90D	3
	48394	FPM	Washer, Seal - 90D	3
99	† 48201	SSL	Retainer, Plunger w/Stud (M6)	3
100	46541	PVDF	Retainer, Seal	3
106	43243	NBR	Seal, LPS w/S-Spg	3
	44926	FPM	Seal, LPS w/SS-Spg	3
	76243	ST	Seal, LPS w/S-Spg	3
120	46625	BB	Case, Seal	3
	49426	BB	Case, Seal (use w/76243, 13976)	3
121	13976	NBR	O-Ring, Seal Case - 70D	3
	48522	FPM	O-Ring, Seal Case	3
125	43245	SNG	Seal, HPS w/S	3
	44925	FPM	Seal, HPS w/SS	3
	46652	HT	Seal, HPS "Hi-Temp", 2-Pc w/S-Support	3
	76245	ST	Seal, HPS w/S	3
139	43448	BB	Plug, Inlet (1/2"NPT)	1
163	17547	NBR	O-Ring, Seat - 85D	6
	11685	FPM	O-Ring, Seat - 85D	6
164	45790	S	Seat	6
166	43723	S	Valve	6
167	43750	S	Spring	6
168	44565	PVDF	Retainer, Spring	6
172	17615	NBR	O-Ring, Valve Plug - 75D	6
	15855	FPM	O-Ring, Valve Plug - 70D	6
174	46756	BB	Plug, Valve	6
185	46616	FBB	Manifold, Head	1
188	126512	STCP R	Screw, HSH (M8x65)	8
196	22187	BBCP	Plug, Discharge (3/8"NPT)	1
250	118672	STCP	Protector, Shaft	1
260	30612	STZP	Mount, Rail Assy	1
265	30641	—	Mount, Assy (Incls: 30612, 30032, 30047, 118672)	1
270	30246	STL	Assy, Pulley & Key (Incls: 30032, 30047)	1
	—	—	[See Drive Packages, Tech Bulletin 003]	
283	34334	—	Kit, Oil Drain	1
299	814841	FBB	Head, Complete	1
300	33983	NBR	Kit, Seal (Incls: 98, 106, 121, 125)	1
	33257	FPM	Kit, Seal (Incls: 98, 106, 121, 125)	1
	31983	HT	Kit, Seal (Incls: 98, 106, 121, 125)	1
	76526	STHT	Kit, Seal (Incls: 98, 106, 120, 121, 125)	1
310	33062	NBR	Kit, Valve (Incls: 163, 164, 166, 167, 168, 172)	2
	33258	FPM	Kit, Valve (Incls: 163, 164, 166, 167, 168, 172)	2
350	30696	STZP	Plier, Reverse	1
500	8075	—	Gearbox (See Individual Data Sheet)	1
—	6107	—	Oil, Bottle (21 oz.) ISO 68 Multi-viscosity Hydraulic (Fill to specified crankcase capacity prior to start-up)	1

Bold print part numbers are unique to a particular pump model. Italics are optional items. [] Date of latest production change.

† Production parts are different than repair parts. R Components comply with RoHS Directive.

See Tech Bulletins 002, 003, 024, 036, 064, 073, 074, 077 and 083 for additional information.

For motorized versions see BD motor data sheet. For Gearbox version see 8075 data sheet.

MATERIAL CODES (Not Part of Part Number): AL=Aluminum BB=Brass BBBCP=Brass/Chrome Plated BBNP=Brass Nickel Plated CC=Ceramic
 CM=Chrome-moly FBB=Forged Brass FCM=Forged Chrome-Moly FPM=Fluorocarbon HT=Hi-Temp (EPDM Alternative) NBR=Medium Nitrile (Buna-N)
 PVDF=Polyvinylidene Fluoride RTP=Reinforced Composite S=304SS SNG=Special Blend (Buna) SSL=316SS/Low Carbon ST=Polyetheretherketon
 STHT=Special PTFE High Temp STL=Steel STCP=Steel/Chrome Plated STZP=Steel/Zinc Plated TNM=Special High Strength

EXPLODED VIEW

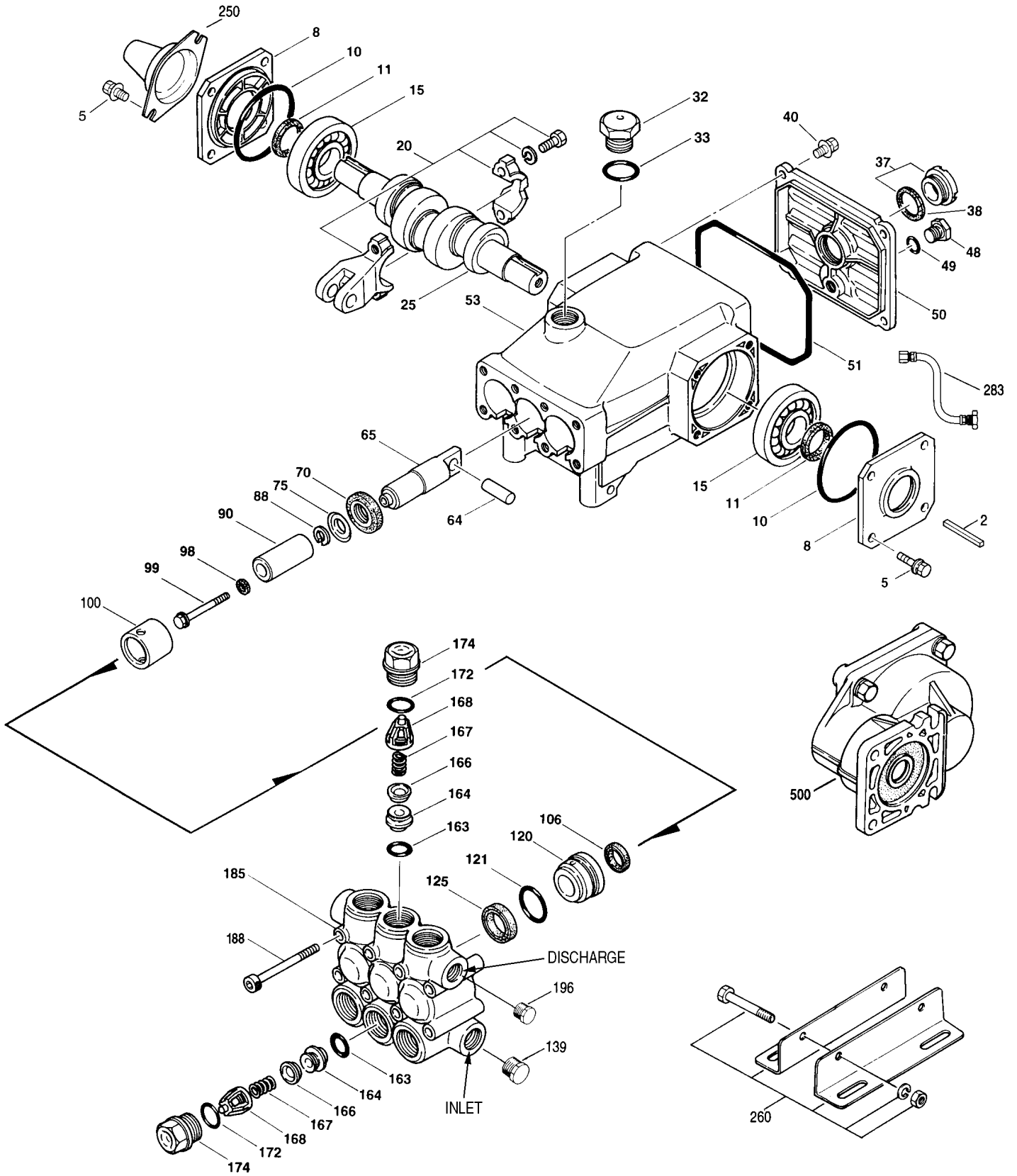

Models
 3CP1120, 3CP1120G,
 3CP1130, 3CP1140
 January 2008

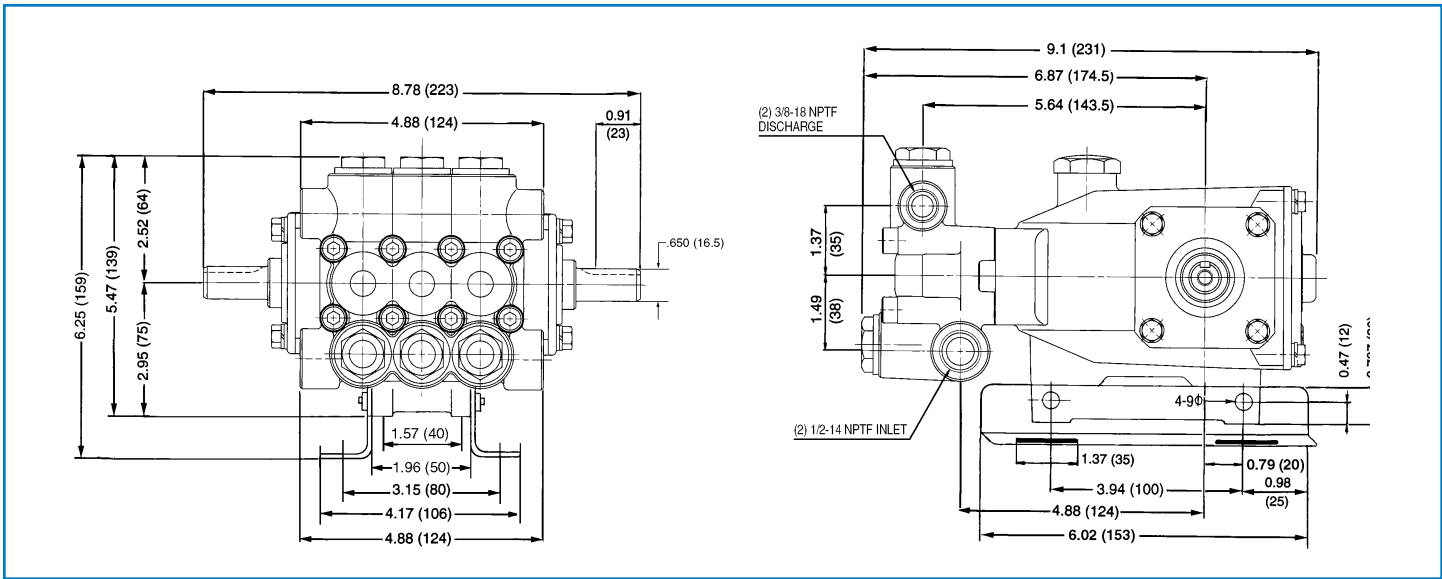

Models 3CP1120, 3CP1120G, 3CP1130, 3CP1140

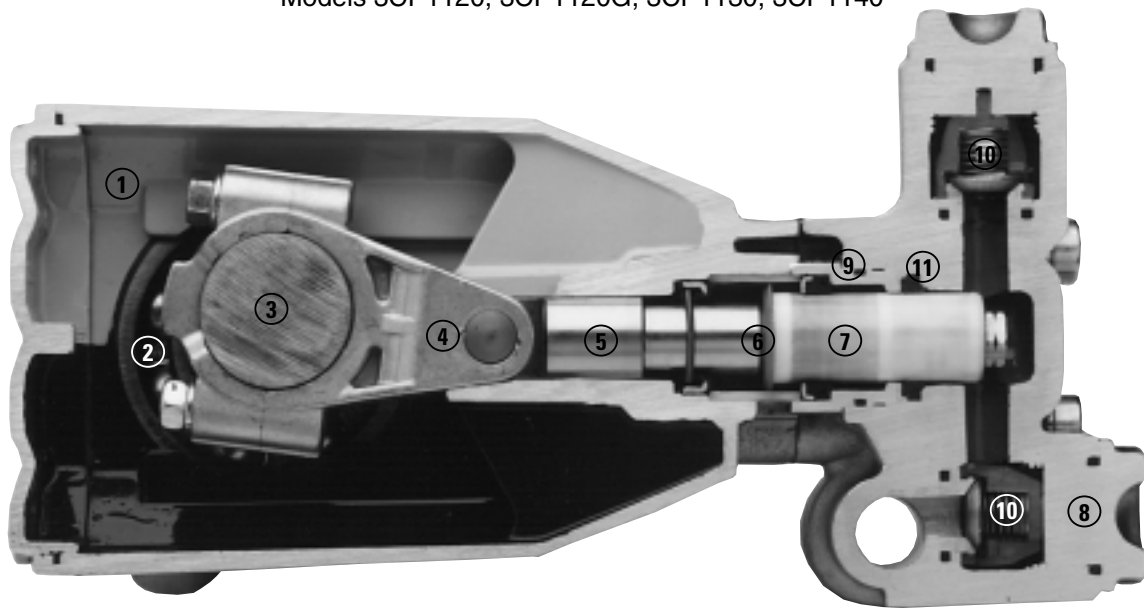

- 1 Die cast aluminum **crankcase** means high strength, lightweight, and excellent tolerance control.
- 2 Oversized crankshaft **bearings** provide extended bearing life and pump performance.
- 3 Chrome-moly **crankshaft** provides unmatched strength and surface hardness for long life.
- 4 Matched oversized TNM **connecting rods** noted for superior tensile strength and bearing quality.
- 5 The **plunger rods** are hardened, surface plated for wear resistance, with high load capacity.
- 6 The stainless steel **slinger** provides back-up protection for the crankcase seal, keeping pumped liquids out of the crankcase.
- 7 Special concentric, high-density, polished, solid ceramic **plungers** provide a true wear surface and extended seal life.
- 8 **Manifolds** are a high tensile strength forged brass for long term, continuous duty.
- 9 100% wet **seal** design adds to service life by allowing pumped liquids to cool and lubricate on both sides of the seals.
- 10 Stainless steel **valves, seats and springs** provide corrosion-resistance, ultimate seating and extended life.
- 11 Specially formulated, CAT PUMP exclusive, **Hi-Pressure Seals** offer unmatched performance and seal life.

World Headquarters
CAT PUMPS
 1681 - 94th Lane N.E. Minneapolis, MN 55449-4324
 Phone (763) 780-5440 — FAX (763) 780-2958
 e-mail: techsupport@catpumps.com
 www.catpumps.com

International Inquiries
 FAX (763) 785-4329
 e-mail: intlsales@catpumps.com



CAT PUMPS (U.K.) LTD.
 1 Fleet Business Park, Sandy Lane, Church Crookham
 FLEET, Hampshire, GU52 8BF, England
 Phone Fleet 44 1252-622031 — Fax 44 1252-626655
 e-mail: sales@catpumps.co.uk

N.V. CAT PUMPS INTERNATIONAL S.A.
 Heiveldekens 6A, B-2550 Kontich, Belgium
 Phone 32-3-450.71.50 — Fax 32-3-450.71.51
 e-mail: cpi@catpumps.be www.catpumps.be

CAT PUMPS DEUTSCHLAND GmbH
 Buchwiese 2, D-65510 Idstein, Germany
 Phone 49 6126-9303 0 — Fax 49 6126-9303 33
 e-mail: catpumps@t-online.de www.catpumps.de