

38 Frame Block-Style Stainless Steel Plunger Pump

**Standard
Models**

3841

**Flushed
Models**

3841K

FEATURES

Superior Design

- Triplex plunger design provides smoother liquid flow.
- Oil bath crankcase assures optimum lubrication.
- Close tolerance concentricity of the ceramic plunger maximizes seal life.
- **Standard Models:** Lo-Pressure Seals and V-Packings are completely lubricated and cooled by the liquid being pumped.
- **K Models:** Special Flushed Inlet Manifold permits flush for added cooling with high temperature liquids and lubrication with low lubricity liquids.

Quality Materials

- Precision design 316 stainless steel valves are hardened and polished for ultimate seating and extended valve life.
- 316 SSL block-style manifolds for strength and corrosion resistance.
- Special concentric, high-density, polished, solid ceramic plungers provide a true wear surface and extended seal life.
- Specially formulated, CAT PUMP exclusive, V-Packings offers unmatched performance and seal life.
- Die cast aluminum crankcase provides high strength, minimum weight and precision tolerance control.
- Optional Cast Iron crankcase for hazardous environments.
- Chrome-moly crankshaft gives unmatched strength and surface hardness.
- Oversized crankshaft bearings with greater loading capacity means longer bearing life.

Easy Maintenance

- Wet-end is easily serviced without entering crankcase, requiring less time and effort.
- Inlet and discharge valve assemblies interchange for easier maintenance without disturbing piping.
- Preset packings mean no packing gland adjustment is necessary, reducing maintenance costs.

⚠ WARNING

All systems require both a primary pressure regulating device (i.e., regulator, unloader) and a secondary pressure safety relief device (i.e., pop-off valve, safety valve). Failure to install such relief devices could result in personal injury or damage to the pump or to system components. CAT PUMPS does not assume any liability or responsibility for the operation of a customer's high pressure system.

SPECIFICATIONS

	U.S. Measure	Metric Measure
Flow.....	45 GPM	(170 L/M)
Pressure Range.....	100 to 1000 PSI	(7 to 70 BAR)
Inlet Pressure Range*.....	Flooded to 70 PSI	(Flooded to 4.9 BAR)
RPM.....	765 RPM	(765 RPM)
Bore.....	1.772"	(45 mm)
Stroke.....	1.890"	(48 mm)
Crankcase Capacity.....	4.2 Qts.	(4 L)
Maximum Liquid Temperature.....	140°F	(60°C)
Above 130°F call CAT PUMPS for inlet conditions and elastomer recommendations.		
Inlet Ports (2).....	1-1/2" NPTF	(1-1/2" NPTF)
Flushing Ports (2)*.....	1/2" NPTF	(1/2" NPTF)
Discharge Ports (2).....	1" NPTF	(1" NPTF)
Shaft Diameter.....	1.378"	(35 mm)
Weight.....	139 lbs.	(63 kg)
Dimensions.....	24.8 x 18.11 x 9.37"	(620 x 460 x 238 mm)

* K Models: Special Flushed Inlet Manifold permits external flush for added cooling with high temperature liquids and lubrication with low lubricity liquids.

ELECTRIC HORSEPOWER REQUIREMENTS

FLOW		PRESSURE			RPM
		PSI 800	PSI 900	PSI 1000	
U.S. GPM	L/M	BAR 55	BAR 63	BAR 70	
45	170	24.7	27.8	30.9	765
40	151	22.0	24.7	27.4	680
35	133	19.2	21.6	24.0	595

**DETERMINING
THE PUMP R.P.M.**

$\frac{\text{Rated G.P.M.}}{\text{Rated R.P.M.}} = \frac{\text{"Desired" G.P.M.}}{\text{"Desired" R.P.M.}}$

**DETERMINING
THE REQUIRED H.P.**

$\frac{\text{GPM} \times \text{PSI}}{1460} = \text{Electric Brake H. P. Required}$

**DETERMINING
MOTOR PULLEY SIZE**

$\frac{\text{Motor Pulley O.D.}}{\text{Pump R.P.M.}} = \frac{\text{Pump Pulley O.D.}}{\text{Motor R.P.M.}}$

See complete Drive Packages [Inclds: Pulleys, Belts, Hubs, Key] Tech Bulletin 003. Refer to pump **Service Manual** for repair procedure, additional technical information and **pump warranty**.

"Customer confidence is our greatest asset"

PARTS LIST

ITEM	PART NUMBER		DESCRIPTION	QTY	
	3841	MATL 3841K	MATL		
2	34021	STL	34021 STL	Key (M10x8x70)	1
5	125753	S	125753 S	Screw, HH Sems (M8x25)	8
8	44542	AL	44542 AL	Cover, Bearing	2
9	815279	FBR	815279 FBR	Shim, Split 2-Pc	0-2
10	12398	NBR	12398 NBR	O-Ring, Bearing Cover - 70D	2
11	13296	NBR	13296 NBR	Seal, Oil, Crankshaft	2
15	29326	STL	29326 ST	Bearing, Roller	2
20	121467	TNM	121467 TNM	Rod, Connecting Assy (Incls: 21,22,23) [10/00]	3
21	126749	STCP R	126749 STCP R	Washer, Locking	3
22	126574	STCP R	126574 STCP R	Washer, Flat (M10)	6
23	122045	STZP	122045 STZP	Screw, HH (M10x55)	6
25	29325	FCM	29325 FCM	Crankshaft, Dual End (M48)	1
31	828710	—	828710 —	Protector, Oil Cap w/Foam Gasket	1
32	43211	ABS	43211 ABS	Cap, Oil Filler	1
33	14177	NBR	14177 NBR	O-Ring, Oil Filler Cap - 70D	1
34	126743	STCP R	126743 STCP R	Bolt, Eye (M12x1.75) (For Lifting Pump Only)	1
37	92241	—	92241 —	Gauge, Oil, Bubble w/Gasket - 80D	1
38	44428	NBR	44428 NBR	Gasket, Flat - 80D	1
40	125753	S	125753 S	Screw, HH Sems (M8x25)	8
48	25625	STCP	25625 STCP	Plug, Drain (1/4"x19BSP)	1
49	23170	NBR	23170 NBR	O-Ring, Drain Plug - 70D	1
50	45936	AL	45936 AL	Cover, Rear	1
51	16612	NBR	16612 NBR	O-Ring, Cover - 70D	1
53	44487	AL	44487 AL	Crankcase Assy (Incls: 34, 54)	1
55	27488	S	27488 S	Pins, Guide	2
64	43864	CM	43864 CM	Pin, Crosshead	3
65	45116	SSZZ	45116 SSZZ	Rod, Plunger	3
69	126587	STZP	126587 STZP	Washer, Oil Seal	3
70	100488	NBRS	100488 NBRS	Seal, Oil, Crankcase	3
	44739	FPM	44739 FPM	Seal, Oil, Crankcase	3
75	43865	S	43865 S	Slinger, Barrier	3
88	45676	S	45676 S	Washer, Keyhole (M16)	3
90	46806	CC	46806 CC	Plunger (M45x145)	3
95	89778	SS	89778 SS	Stud, Plunger Retainer (M10x135)	3
96	20189	PTFE	20189 PTFE	Back-up-Ring, Plunger Retainer	3
97	11345	NBR	11345 NBR	O-Ring, Plunger Retainer - 70D	3
	11375	FPM	11375 FPM	O-Ring, Plunger Retainer	3
	701490	EPDM	701490 EPDM	O-Ring, Plunger Retainer	3
98	44085	SS	44085 SS	Gasket, Plunger Retainer	3
99	44084	SS	44084 SS	Retainer, Plunger (M10)	3
100	44119	PPG	44119 PPG	Retainer, Seal	3
106	48384	NBR	48384 NBR	Seal, LPS w/SS-Spg	3
	702013	SFTB*	702013 SFTB*	Seal, LPS w/SS-Spg	3
	46945	EPDM	46945 EPDM	Seal, LPS w/SS-Spg	3
107	48380	D	48380 D	Spacer, LPS	3
110	701865	SSL	—	Manifold, Inlet, Block-Style	1
	—	—	701982 SSL	Manifold, Inlet, Block-Style, Flushed (1/2" NPTF Flush)	1
111	701116	SS	701116 SS	Plug, Inlet (1-1/2" NPT)	1
112	701632	NBR	701632 NBR	O-Ring, Inlet Spacer	6
	701328	FPM	701328 FPM	O-Ring, Inlet Spacer	6
	701973	EPDM	701973 EPDM	O-Ring, Inlet Spacer	6
113	701329	PTFE	701329 PTFE	Back-up-Ring, Inlet Spacer	6
114	701327	SS	701327 SS	Spacer, Inlet	3
117	44585	S	44585 S	Screw, HSH (M14x40)	4
118	70177	SS	—	Plug (1/4" NPT)	3
126	48383	D	48383 D	Adapter, Female	3
127	46813	STG*	46813 STG*	V-Packing	6
	703080	SFTB*	703080 SFTB*	V-Packing	6
128	48386	SS	48386 SS	Adapter, Male	3
141	45113	SS	45113 SS	Spring, Coil	6/18
142	48382	SS	48382 SS	Spacer w/Coil Springs	3
155	17784	NBR	17784 NBR	O-Ring, Spacer - 80D	3
	20138	FPM	20138 FPM	O-Ring, Spacer - 80D	3
	701658	EPDM	701658 EPDM	O-Ring, Spacer - 80D	3
157	48381	SS	48381 SS	Spacer, V-Packing	3
159	17784	NBR	17784 NBR	O-Ring, Spacer - 80D	3
	20138	FPM	20138 FPM	O-Ring, Spacer - 80D	3
	701658	EPDM	701658 EPDM	O-Ring, Spacer - 80D	3
163	26143	NBR	26143 NBR	O-Ring, Seat	6
	14331	FPM	14331 FPM	O-Ring, Seat	6
	701660	EPDM	701660 EPDM	O-Ring, Seat	6
164	48393	SS	48393 SS	Seat	6
166	44108	SS	44108 SS	Valve	6
167	44109	SS	44109 SS	Spring	6
168	44728	PVDF	44728 PVDF	Retainer, Spring	6
170	44729	SS	44729 SS	Washer, Spring Retainer	6
171	44644	SS	44644 SS	Spring, Coil (70kg), Valve Plug	6
172	89827	NBR	89827 NBR	O-Ring, Valve Plug - 90D	6
	11747	FPM	11747 FPM	O-Ring, Valve Plug - 90D	6
	701494	EPDM	701494 EPDM	O-Ring, Valve Plug - 70D	6
173	48364	D	48364 D	Back-up-Ring, Valve Plug	6
174	701278	SS	701278 SS	Plug, Valve	6
176	701316	SS	701316 SS	Cover, Valve	2
177	87951	S	87951 S	Screw, HSH (M10x30)	32
185	701866	SSL	701866 SSL	Manifold, Discharge, Block-Style	1
188	701279	S	701279 S	Screw, HSH (M12x100)	8
196	701342	SS	701342 SS	Plug, Discharge (1" NPT) Not Shown	1

Replace as a set

EXPLODED VIEW

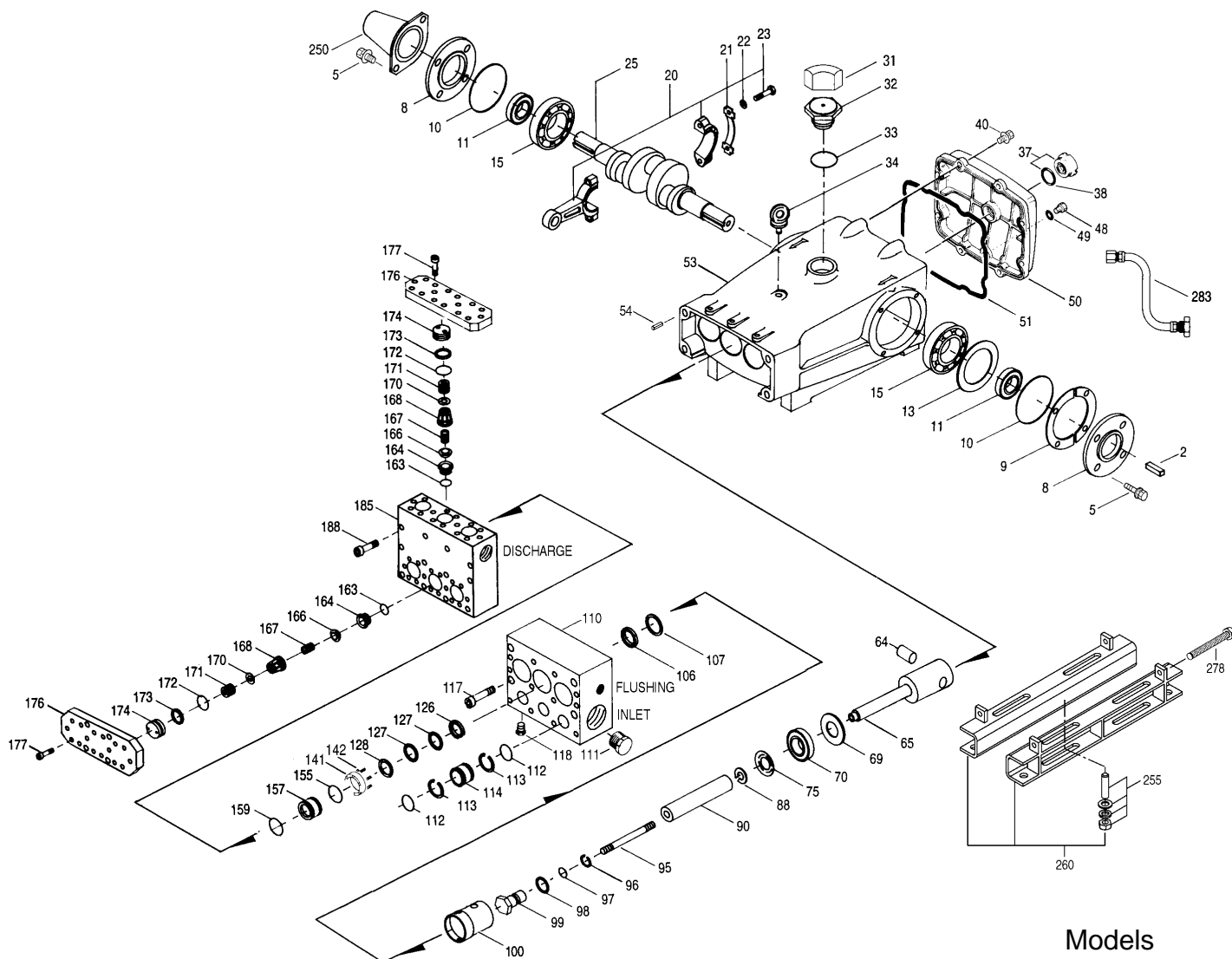

Models
 Standard - 3841
 Flushed - 3841K
 February 2009

	3841	MATL	3841K	MATL		
250	44516	NY	44516	NY	Protector, Shaft w/2 Screws, Lockwashers and Washers (Included with Pump)	1
255	34039	S	34039	S	Assy, Direct Mount	1
260	92674	STZP	92674	STZP	Mount, Rail Assy (Incls: 34018)	1
275	990013	STL	990013	STL	Hub, "B" (35mm w/keyway) [See Drive Packages Tech Bulletin 003]	1
278	80540	ZP	80540	ZP	Screw, HH (M12x100) (Rail Adjusting Screw)	1
283	34314	—	34314	—	Kit, Oil Drain (3/8" x 48")	1
290	6124	—	6124	—	Gasket, Liquid (3 oz.)	1
299	901410	SSL	—	—	Head, Complete, Block-Style	1
300	—	—	901411	SSL	Head, Complete, Block-Style, Flushed	1
	31934	NBR*	31934	NBR*	Kit, Seal (Incls: 97, 106, 112, 113, 127, 155, 159)	1
	31961	FPM*	31961	FPM*	Kit, Seal (Incls: 97, 106, 112, 113, 127, 155, 159)	1
	◆ 31923	EPDM*	◆ 31923	EPDM*	Kit, Seal (Incls: 97, 106, 112, 113, 127, 155, 159)	1
310	33835	NBR	33835	NBR	Kit, Valve, Preamsembled (Incls: 163, 164, 166, 167, 168, 170, 172, 173)	2
	31262	FPM	31262	FPM	Kit, Valve (Incls: 163, 164, 166, 167, 168, 170, 172, 173)	2
	◆ 31264	EPDM	◆ 31264	EPDM	Kit, Valve (Incls: 163, 164, 166, 167, 168, 170, 172, 173)	2
—	819000	F	819000	F	Assembly, Crankcase, Cast Iron Conversion	1
370	—	—	990663	—	Assembly, Flushing, 5 gal., 115V, 1.1 Amp, 1/2" NPT	1
390	714500	SS	714500	SS	C.A.T. (Inlet pressure stabilizer for RO and boosted applications)	1
391	714506	SS	714506	SS	Adapter (2 per C.A.T.) (See Data Sheet for complete selection)	2
392	701828	SS	701828	SS	Elbow Assy used with Adapter Assy 714506	1
—	6100	—	6100	—	Oil, Case (12-21 oz. Bottles) ISO-68 Hydraulic (Fill to specified crankcase capacity prior to start-up)	1

Bold print part numbers are unique to a particular pump model. *Italics are optional items.* [] Date of latest production change. ◆ Silicone oil/grease required.

R Components comply with RoHS Directive. * Review individual parts in each kit for material code identification.

See Tech Bulletins 002, 003, 024, 035, 036, 041, 043, 053, 074, 077, 083, 095 and 105 for additional information. **C.A.T. highly recommended for pressurized inlet, R.O. and industrial applications.**

MATERIAL CODES (Not Part of Part Number): ABS=ABS Plastic AL=Aluminum CC=Ceramic CM=Chrome-Moly D=Acetal EPDM=Ethylene Propylene Diene Monomer F=Cast Iron FBR=Fiber

FCM=Forged Chrome-moly FPM=Fluorocarbon NBR=Medium Nitrile (Buna-N) NBRs=Buna, Silicone Free NY=Nylon PPG=Glass Filled Polypropylene PTFE=Pure Polytetrafluoroethylene

PVDF=Polyvinylidene Fluoride S=304SS SFTB=Special Blend PTFE Black SSL=316SS/Low Carbon SSZZ=316SS/Zamak STG=Special Blend PTFE White STL=Steel

STZP=Steel/Zinc Plated TNM=Special High Strength ZP=Zinc Plated

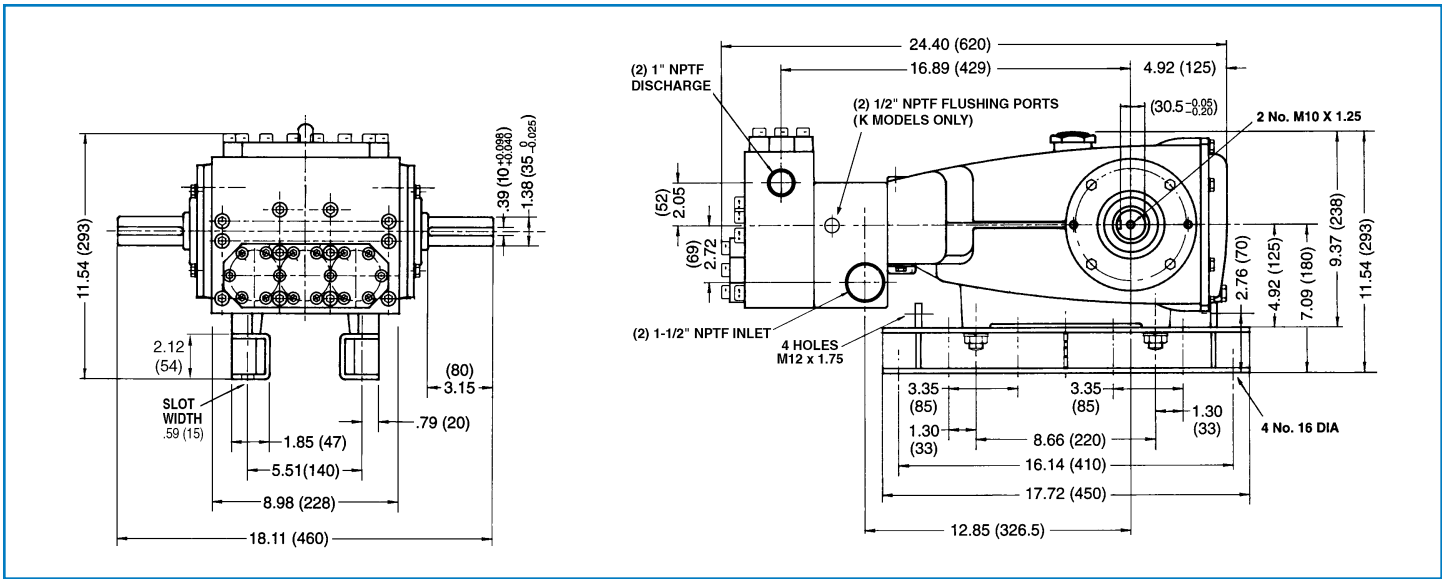

Models 3841, 3841K

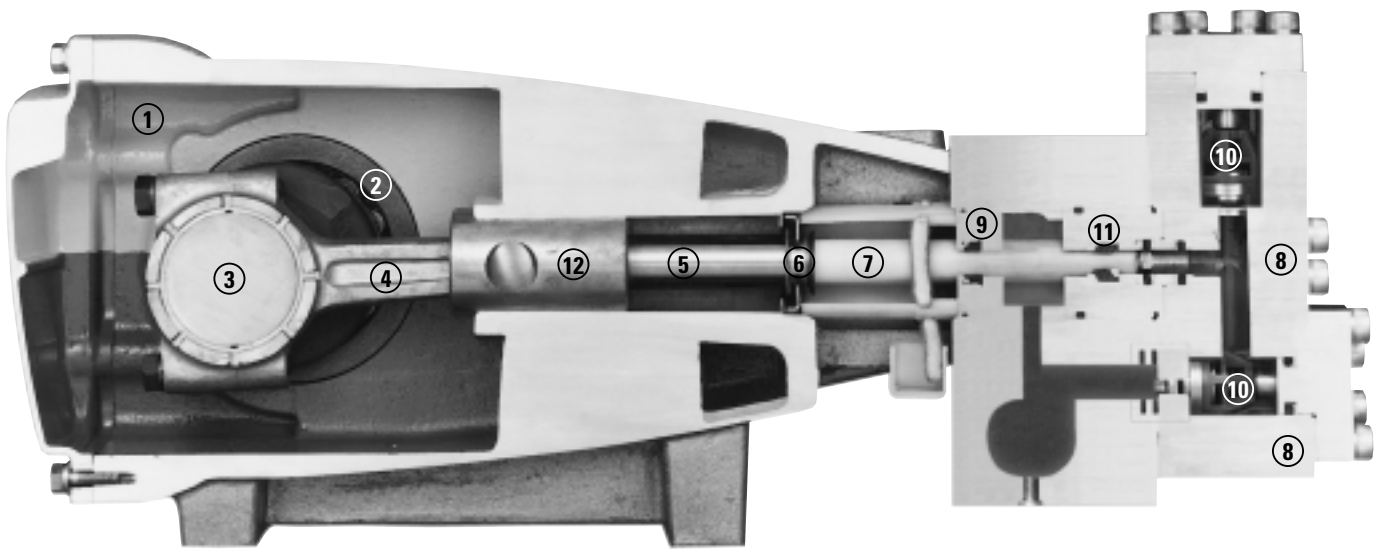

- 1 Die cast aluminum **crankcase** means high strength, lightweight, and excellent tolerance control.
- 2 Oversized crankshaft **bearings** provide extended bearing life and pump performance.
- 3 Chrome-moly **crankshaft** provides unmatched strength and surface hardness for long life.
- 4 Matched oversized high strength TNM **connecting rods** noted for superior strength and bearing quality.
- 5 Special stainless steel **plunger rods** with high strength crossheads for longevity and corrosion resistance.
- 6 The stainless steel **slinger** provides back-up protection for the crankcase seal, keeping pumped liquids out of the crankcase.
- 7 Special concentric, high-density, polished, solid ceramic **plungers** provide a true wear surface and extended seal life.
- 8 **Manifolds** are 316 SSL block-style for long-term continuous-duty and corrosion resistance.
- 9 **Standard Models:** Lo Pressure Seals and V-Packings are completely lubricated and cooled by the liquid being pumped.
- 9 Special **Flushed Inlet Manifold** permits external flush for added cooling with high temperature liquids and lubrication with low lubricity liquids.
- 10 Stainless steel **valves, seats and springs** provide corrosion-resistance, ultimate seating and extended life.
- 11 Specially formulated, CAT PUMP exclusive, **V-Packings** offer unmatched performance and seal life.
- 12 **Crossheads** are 360° supported for uncompromising alignment.

World Headquarters
CAT PUMPS
 1681 - 94th Lane N.E. Minneapolis, MN 55449-4324
 Phone (763) 780-5440 — FAX (763) 780-2958
 e-mail: techsupport@catpumps.com
 www.catpumps.com

International Inquiries
 FAX (763) 785-4329
 e-mail: intlsales@catpumps.com



CAT PUMPS (U.K.) LTD.
 1 Fleet Business Park, Sandy Lane, Church Crookham
 FLEET, Hampshire, GU52 8BF, England
 Phone Fleet 44 1252-622031 — Fax 44 1252-626655
 e-mail: sales@catpumps.co.uk www.catpumps.co.uk

N.V. CAT PUMPS INTERNATIONAL S.A.
 Heiveldekens 6A, B-2550 Kontich, Belgium
 Phone 32-3-450.71.50 — Fax 32-3-450.71.51
 e-mail: cpi@catpumps.be www.catpumps.be

CAT PUMPS DEUTSCHLAND GmbH
 Buchwiese 2, D-65510 Idstein, Germany
 Phone 49 6126-9303 0 — Fax 49 6126-9303 33
 e-mail: catpumps@t-online.de www.catpumps.de