

# DATA SHEET

## SPRAY GUNS



**Standard Model: 36140**

**Weep Model: 36141**



36141 Weep Model

### FEATURES

- Durable Z-Nylon body with new heat resistant trigger means longer life, less breakage.
- Contour design and smooth trigger action reduces operator fatigue.
- Quality construction stainless steel ball and seat assures thousands of continuous cycles.
- Choice of standard or freeze protection “weep” version.
- Special safety-lock prevents unintentional operation.

### COMMON SPECIFICATIONS

	U.S.	Metric
Max Flow	10.5 gpm	39.7 lpm
Max Pressure	5000 psi	345 bar
Max Temperature	300° F	149° C
Inlet Port	3/8" NPT(F)	3/8" NPT(F)
Discharge Port	1/4" NPT(F)	1/4" NPT(F)
Weight	36.8 oz.	1.03 kg
Dimensions	8.49 x 5.23 x 1.23"	216 x 133 x 31 mm

Use only at above specifications to assure proper gun life and performance.

### SELECTION

Select a gun to match your system flow and pressure requirements, temperature and function being performed.

### INSTALLATION

Install the appropriate relief valve when using a spray gun to avoid pressure spikes when the gun is shut off. Severe damage can occur to your system without this device. When operating in freezing conditions, use the weep version. For field conversion a standard gun may be modified to weep by **inverting the standard seat to the notched weep side**. It is recommended the color coded trigger also be used when converting to weep.

### OPERATION

Flow through the gun occurs by squeezing the trigger on the gun. This activates the actuator rod, lifting the ball off the seat, allowing the pumped liquid to flow through the valve body chamber in the gun. Releasing the trigger shuts off the flow.

### TROUBLESHOOTING

Water leaking out the discharge of the gun	<ul style="list-style-type: none"> <li>• Object lodged between the seat and ball.</li> <li>• Seat worn.</li> <li>• O-Ring under seat worn.</li> </ul>
Water leaking out the lever area	<ul style="list-style-type: none"> <li>• O-Ring around push rod worn.</li> </ul>

### ⚠ WARNING

Severe injury can occur with high pressure spray. Do not allow spray to contact any part of body.

## EXPLODED VIEW

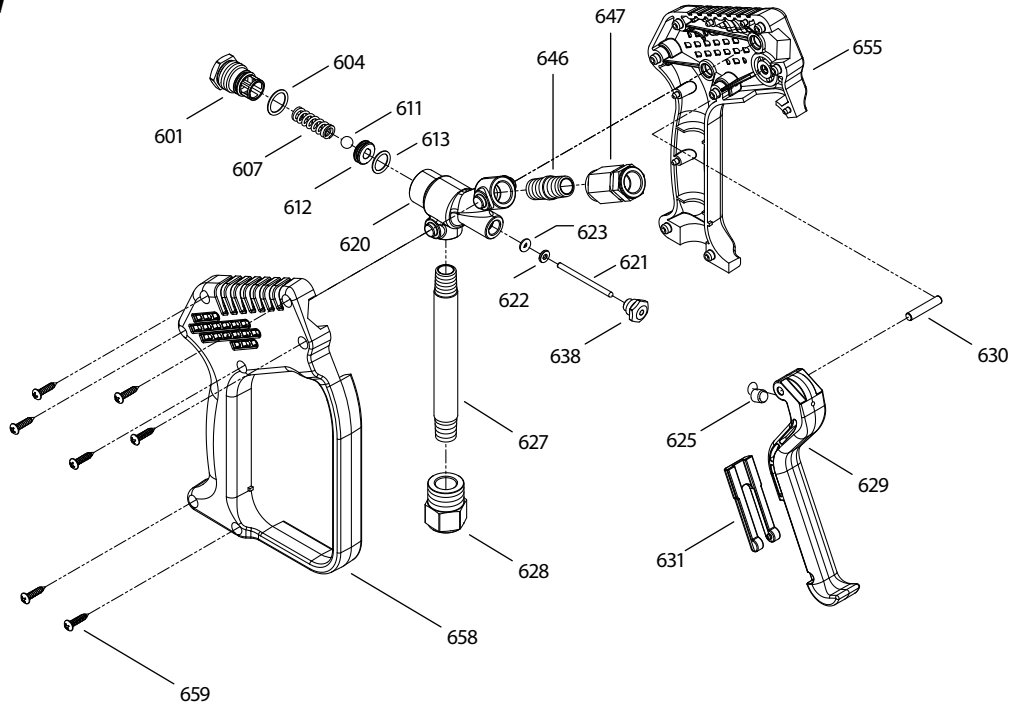

## PARTS LIST

ITEM	P/N	MATL	DESCRIPTION	QTY	ITEM	P/N	MATL	DESCRIPTION	QTY
601	—	BB	Plug, Spring Retaining	1	628	77012	BB	Fitting, Inlet [3/8" NPT(F)]	1
604	31474	FPM	O-Ring, Plug - 90D	1	629	—	Z	Trigger	1
607	77042	SS	Spring, Valve	1	630	—	BB	Pin, Trigger	1
611	77024	SSSS	Ball, Valve	1	631	77018	Z	Latch, Safety, Black	1
612	77006	S	Seat, Notched	1		77019	Z	Latch, Safety, Blue	1
613	77008	FPM	O-Ring, Seat - 90D	1	638	77005	BB	Plug, Pin Guide	1
620	—	BB	Body, Valve	1	646	77038	S	Nipple, Discharge [1/4" NPT(M)]	1
621	33787	S	Pin, Actuator	1	647	77039	BB	Fitting, Discharge [1/4" NPT(F)]	1
622	35074	PTFE	Backup-Ring, Actuator Pin	1	655	—	Z	Handle, Left	1
623	77007	FPM	O-Ring, Actuator Pin	1	658	—	Z	Handle, Right	1
625	—	S	Plug, Striker	1	659	—	S	Screw, Pan Head (M3.5x16)	7
627	—	S	Nipple, Inlet [1/4" NPT(F)]	1	668	36080	FPM	Kit, Repair (Incls: 604,611,612,613,622,623)	1

MATERIAL CODES (Not Part of Part Number):

BB=Brass FPM=Fluorocarbon PTFE=Pure Polytetrafluoroethylene S=304SS SS=316SS SSSS=440SS Z=Z-Nylon

## OPTIONAL LANCES

31219 Square Insulated Single Lance - S.S. — 32"-1/4", 5100 PSI

31220 Square Insulated Single Lance - S.S. — 42"-1/4", 5100 PSI

### ⚠ CAUTIONS AND WARNINGS

All High Pressure Systems require a primary pressure regulating device (i.e. regulator, unloader) and a secondary pressure relief device (i.e. pop-off valve, relief valve). Failure to install such relief devices could result in personal injury or damage to pump or property. Cat Pumps does not assume any liability or responsibility for the operation of a customer's high pressure system.

Read all CAUTIONS and WARNINGS before commencing service or operation of any high pressure system. The CAUTIONS and WARNINGS are included in each service manual and with each Accessory Data sheet. CAUTIONS and WARNINGS can also be viewed online at [www.catpumps.com/cautions-warnings](http://www.catpumps.com/cautions-warnings) or can be requested directly from Cat Pumps.

### WARRANTY

View the Limited Warranty on-line at [www.catpumps.com/warranty](http://www.catpumps.com/warranty).



### CAT PUMPS

1681 - 94TH LANE N.E. MINNEAPOLIS, MN 55449-4324  
 PHONE (763) 780-5440 — FAX (763) 780-2958  
 e-mail: [techsupport@catpumps.com](mailto:techsupport@catpumps.com)  
[www.catpumps.com](http://www.catpumps.com)