

Model 3535 Shown  
(Shaft protector included, mounting rails sold separately)

## FEATURES

- Triplex design delivers high efficiency and low pulsation.
- Durable dual V-Packings are lubricated and cooled by pumped liquid.
- Pre-set Lo-Pressure Seals provide secondary protection against external leaks and require no packing adjustments.
- Special high-density, polished, concentric plungers provide a true wear surface and extended seal life.
- Specially formulated Seals and V-Packings offer unmatched performance and extended life.
- Interchangeable inlet and discharge valves for easy servicing.
- Wet-end easily serviced without entering crankcase.

### ⚠ CAUTIONS AND WARNINGS

All High Pressure Systems require a primary pressure regulating device (i.e. regulator, unloader) and a secondary pressure relief device (i.e. pop-off valve, relief valve). Failure to install such relief devices could result in personal injury or damage to pump or property. CAT PUMPS does not assume any liability or responsibility for the operation of a customer's high pressure system.

Read all CAUTIONS and WARNINGS before commencing service or operation of any high pressure system. The CAUTIONS and WARNINGS are included in each service manual and with each Data sheet. CAUTIONS and WARNINGS can also be viewed online at [www.catpumps.com/cautions-warnings](http://www.catpumps.com/cautions-warnings) or can be requested directly from CAT PUMPS.

### WARRANTY

View the Limited Warranty on-line at [www.catpumps.com/warranty](http://www.catpumps.com/warranty).

## 35 Frame Plunger Pump

**Brass**  
Standard and Flushed **3535, 3535C**

**Stainless Steel**  
Standard and Flushed **3531, 3531C**

**Nickel Aluminum Bronze**  
Standard **3537**

### SPECIFICATIONS

	U.S. Measure	Metric Measure
Flow .....	36 gpm	(136l/m)
Pressure Range.....	100 to 1200 psi	(7 to 85 bar)
Inlet Pressure Range .....	Flooded to 70 psi	(Flooded to 4.9 bar)
RPM.....	800 rpm	(800 rpm)
Bore.....	1.575"	(40 mm)
Stroke.....	1.890"	(48 mm)
Crankcase Capacity .....	4.2 Qts.	(4 l)
Maximum Liquid Temperature .....	160°F	(70°C)
Above 130°F call CAT PUMPS for inlet conditions and elastomer recommendations.		
Inlet Ports (2) .....	1-1/2" NPTF	(1-1/2 NPTF)
Flushing Ports (2) (3531C,3535C).....	1/4" NPTF	1/4" NPTF
Discharge Ports (2).....	1" NPTF	(1" NPTF)
Pulley Mounting.....	Either Side	(Either Side)
Shaft Diameter.....	1.378"	(35 mm)
Weight .....	139 lbs.	(63 kg)
Dimensions (3535, 3535C) .....	23.87 x 18.11 x 9.72"	(606.5 x 460 x 247 mm)
Dimensions (3531,3531C, 3537) .....	24.33 x 18.11 x 9.72"	(618 x 460 x 247 mm)

### ELECTRIC HORSEPOWER REQUIREMENTS

FLOW		PRESSURE			rpm	DRIVE
U.S.		psi	psi	psi		
gpm	l/m	800	1000	1200		Consult CAT PUMPS for Pump and Motor Pulley Sizes
36	136	19.8	24.7	29.7	800	
30	114	16.5	20.6	24.7	667	
25	95	13.7	17.2	20.6	556	

<b>DETERMINING THE PUMP rpm</b>	$\frac{\text{Rated gpm}}{\text{Rated rpm}}$	=	$\frac{\text{"Desired" gpm}}{\text{"Desired" rpm}}$
<b>DETERMINING THE REQUIRED H.P.</b>	$\frac{\text{gpm x psi}}{1460}$	=	Electric Brake H. P. Required
<b>DETERMINING MOTOR PULLEY SIZE</b>	$\frac{\text{Motor Pulley O.D.}}{\text{Pump rpm}}$	=	$\frac{\text{Pump Pulley O.D.}}{\text{Motor rpm}}$

See complete Drive Packages [Incls: Pulleys, Belts, Hubs, Key] Tech Bulletin 003.  
Refer to pump **Service Manual** for repair procedure and additional technical information.

*"Customer confidence is our greatest asset"*

# PARTS LIST

ITEM	PART NUMBER		DESCRIPTION		QTY
	3535	3531	3537		
	MATL	MATL	MATL		
2	34021 STL	34021 STL	34021 STL	Key (M10x8x70)	1
5	125753 S	125753 S	125753 S	Screw, HHC Sems (M8x25)	8
8	44542 AL	44542 AL	44542 AL	Cover, Bearing	2
9	815279 FBR	815279 FBR	815279 FBR	Shim, Split 2-Pc	4
10	12398 NBR	12398 NBR	12398 NBR	O-Ring, Bearing Cover - 70D	2
11	13296 NBR	13296 NBR	13296 NBR	Seal, Oil, Crankshaft	2
15	29326 STL	29326 STL	29326 STL	Bearing, Roller	2
20	121467 TNM	121467 TNM	121467 TNM	Rod, Connecting Assy (Incls: 21,22,23) [10/00]	3
21	126749 STCP R	126749 STCP R	126749 STCP R	Locking Washer (M10)	3
22	126574 STZP R	126574 STZP R	126574 STZP R	Washer, Flat (M10)	6
23	122045 STZP	122045 STZP	122045 STZP	Screw, HH (M10x55)	6
25	29325 FCM	29325 FCM	29325 FCM	Crankshaft, Dual End	1
31	828710 —	828710 —	828710 —	Protector, Oil Cap w/Foam Gasket	1
32	43211 ABS	43211 ABS	43211 ABS	Cap, Oil Filler	1
33	14177 NBR	14177 NBR	14177 NBR	O-Ring, Oil Filler Cap - 70D	1
34	126743 STCP R	126743 STCP R	126743 STCP R	Bolt, Eye (M12x1.75) (For Lifting Pump Only)	1
37	92241 —	92241 —	92241 —	Gauge, Oil, Bubble w/Gasket	1
38	44428 NBR	44428 NBR	44428 NBR	Gasket, Flat, Oil Gauge - 80D	1
40	125753 S	125753 S	125753 S	Screw, HHC Sems (M8x25)	8
48	25625 STCP	25625 STCP	25625 STCP	Plug, Drain (1/4"x19BSP)	1
49	23170 NBR	23170 NBR	23170 NBR	O-Ring, Drain Plug - 70D	1
50	45936 AL	45936 AL	45936 AL	Cover, Rear	1
51	16612 NBR	16612 NBR	16612 NBR	O-Ring, Crankcase Cover - 70D	1
53	44487 AL	44487 AL	44487 AL	Crankcase Assy (Incls: 34, 54)	1
54	27488 S	27488 S	27488 S	Pins, Guide	2
56	27790 POP	27790 POP	27790 POP	Pan, Oil	1
59	92538 S	92538 S	92538 S	Screw, HHC Sems (M6x16)	2
64	43864 CM	43864 CM	43864 CM	Pin, Crosshead	3
65	† 45116 SSZZ	45116 SSZZ	45116 SSZZ	Rod, Plunger	3
69	126587 STCP R	126587 STCP R	126587 STCP R	Washer, Oil Seal	3
70	100488 NBR	100488 NBR	100488 NBR	Seal, Oil, Crankcase	3
	44739 FPM	44739 FPM	44739 FPM	Seal, Oil, Crankcase	3
75	43865 S	43865 S	43865 S	Slinger, Barrier	3
88	45676 S	45676 S	45676 S	Washer, Keyhole (M16)	3
90	43921 CC	43921 CC	43921 CC	Plunger (M40x145)	3
95	† 89778 SS	89778 SS	89778 SS	Stud, Plunger Retainer (M10x135)	3
96	20189 PTFE	20189 PTFE	20189 PTFE	Back-up-Ring, Plunger Retainer	3
97	11345 NBR	11345 NBR	11345 NBR	O-Ring, Plunger Retainer - 70D	3
	11375 FPM	11375 FPM	11375 FPM	O-Ring, Plunger Retainer	3
	◆ 701490 EPDM	◆ 701490 EPDM	◆ 701490 EPDM	O-Ring, Plunger Retainer	3
98	44085 SS	44085 SS	44085 SS	Gasket, Retainer	3
99	† 44084 SS	44084 SS	44084 SS	Retainer, Plunger (M10)	3
100	814279 PVDF	814279 PVDF	814279 PVDF	Retainer, Seal, 2 Pc. (See Tech Bulletin 105)	3
101	44112 —	44112 —	44112 —	Wick, Long Tab	3
106	† 44113 NBR	44113 NBR	44113 NBR	Seal, LPS w/SS-Spg	3
	44740 FPM	44740 FPM	44740 FPM	Seal, LPS w/SS-Spg	3
	◆ 46955 EPDM	◆ 46955 EPDM	◆ 46955 EPDM	Seal, LPS w/S-Spg	3
107	—	45381 SS	44115 NAB	Spacer, Lo-Pressure Seal	1
110	49464 BBCP R	45365 SS	45124 NAB	Manifold, Inlet	3
	49464C BBCP R	125397 SS	—	Manifold, Inlet, Flushed (1/4" Flush Ports)	1
112	11379 NBR	11379 NBR	11379 NBR	O-Ring, Inlet Manifold - 70D	3
	14183 FPM	14183 FPM	14183 FPM	O-Ring, Inlet Manifold	3
	◆ 701491 EPDM	◆ 701491 EPDM	◆ 701491 EPDM	O-Ring, Inlet Manifold - 70D	3
117	44585 S	44585 S	44585 S	Screw, HSH (M14x40)	4
126	46494 BB	48391 D	48391 D	Adapter, Female (See Tech Bulletin 087)	3
	—	45367 SS	45367 SS	Adapter Female	3
127	44609 STG*	44609 STG*	44609 STG*	V-Packing	6
	44741 SFG	44741 SFG	44741 SFG	V-Packing	6
128	43928 BB	45368 SS	45368 SS	Adapter, Male	3
141	49519 SS	49519 SS	49519 SS	Spring, Large Coil (See Tech Bulletin 108)	3
155	48860 NBR	48860 NBR	48860 NBR	O-Ring, V-Packing Spacer - 90D	3
	20137 FPM	20137 FPM	20137 FPM	O-Ring, V-Packing Spacer - 70D	3
	◆ 701492 EPDM	◆ 701492 EPDM	◆ 701492 EPDM	O-Ring, V-Packing Spacer	3
156	48362 D	48362 D	48362 D	Back-up-Ring, V-Packing Spacer	3
157	49478 BB	49520 SS	49521 NAB	Spacer, V-Packing (See Tech Bulletin 108)	3
158	48362 D	48362 D	48362 D	Back-up-Ring, V-Packing Spacer	3
159	48860 NBR	48860 NBR	48860 NBR	O-Ring, V-Packing Spacer - 90D	3
	20137 FPM	20137 FPM	20137 FPM	O-Ring, V-Packing Spacer - 70D	3
	◆ 701492 EPDM	◆ 701492 EPDM	◆ 701492 EPDM	O-Ring, V-Packing Spacer	3
162	48363 D	48363 D	48363 D	Back-up-Ring, Valve Seat	6
163	26142 NBR	26142 NBR	26142 NBR	O-Ring, Seat - 80D	6
	14330 FPM	14330 FPM	14330 FPM	O-Ring, Seat	6
	◆ 701493 EPDM	◆ 701493 EPDM	◆ 701493 EPDM	O-Ring, Seat	6
164	44727 S	44612 SS	44612 SS	Seat, Stepped	6
166	43932 S	44108 SS	44108 SS	Valve	6
167	44109 SS	44109 SS	44109 SS	Spring	6
168	44728 PVDF	44728 PVDF	44728 PVDF	Retainer, Spring	6
170	44729 SS	44729 SS	44729 SS	Washer, Spring Retainer	6
171	44644 SS	44644 SS	44644 SS	Coil Spring (70kg), Valve Plug	6
172	89827 NBR	89827 NBR	89827 NBR	O-Ring, Valve Plug - 90D	6
	11747 FPM	11747 FPM	11747 FPM	O-Ring, Valve Plug - 90D	6
	◆ 701494 EPDM	◆ 701494 EPDM	◆ 701494 EPDM	O-Ring, Valve Plug - 70D	6
173	48364 D	48364 D	48364 D	Back-up-Ring, Valve Plug	6
174	46444 FBB	49300 SSD	44643 NAB	Plug, Valve	6
185	49465 BBCP R	49299 SSD	76335 NAB	Manifold, Discharge (See Tech Bulletin 099 and 109)	1
188	89981 S	89981 S	89981 S	Screw, HSH (M12x70)	8
250	44516 NY	44516 NY	44516 NY	Protector, Shaft w/2 Screws, Lockwashers and Washers (Included With Pump)	1

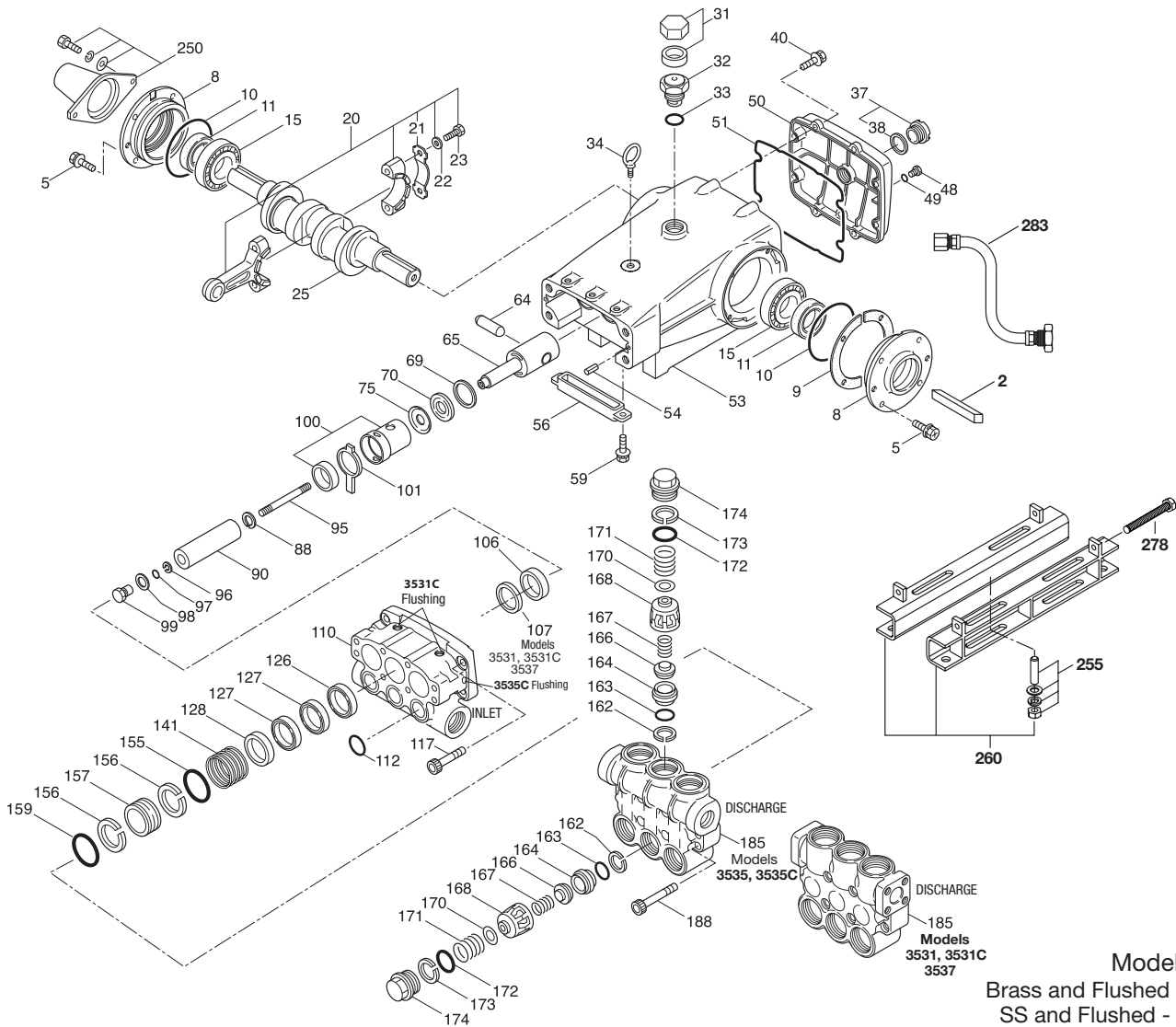

Models  
 Brass and Flushed - 3535, 3535C  
 SS and Flushed - 3531, 3531C  
 NAB and Flushed - 3537  
 March 2010

	<b>3535</b>	<b>3531</b>	<b>3537</b>					
	<b>3535C</b>	<b>MATL</b>	<b>3531C</b>	<b>MATL</b>	<b>3537</b>	<b>MATL</b>		
255	34018	STZP R	34018	STZP R	34018	STZP R	Kit, Direct Mount	1
	34039	S	34039	S	34039	S	Kit, Direct Mount	1
260	92674	STZP R	92674	STZP R	92674	STZP R	Mounting, Box Assy (Incls: 34018)	1
275	990013	STL	990013	STL	990013	STL	Hub, 'B' 35mm w/Keyway (See Tech Bulletin 003)	1
278	80540	ZP	80540	ZP	80540	ZP	Screw, HH (M12x100) (Rail Adjusting Screw)	1
279	30278	STZP	30278	STZP	30278	STZP	Oiler (1 oz.)	3
281	30967	—	30967	—	30967	—	Glass, Oiler	3
282	10069	NBR	10069	NBR	10069	NBR	Gasket, Oiler	3
283	34314	—	34314	—	34314	—	Kit, Oil Drain (3/8" x 48")	1
290	6124	—	6124	—	6124	—	Gasket, Liquid (3 oz.)	1
299	<b>818427</b>	<b>BBCP R</b>	<b>818372</b>	<b>SS</b>	<b>814522</b>	<b>NAB</b>	Complete Head (Models 3535,3531,3537 Only)	1
300	31040	NBR*	31040	NBR*	31040	NBR*	Kit, Seal (Incls: 97,106,112,127,155,156,158,159)	1
	33055	FPM	33055	FPM	33055	FPM	Kit, Seal (Incls: 97,106,112,127,155,156,158,159)	1
	◆ 33262	EPDM*	◆ 33262	EPDM*	◆ 33262	EPDM*	Kit, Seal (Incls: 97,106,112,127,155,156,158,159)	1
310	<b>34235</b>	<b>NBR</b>	<b>34017</b>	<b>NBR</b>	<b>34017</b>	<b>NBR</b>	Kit, Valve, Preassembled (Incls: 162,163,164,166,167,168,170,172,173)	2
	31955	FPM	31955	FPM	31955	FPM	Kit, Valve, Preassembled (Incls: 162,163,164,166,167,168,170,172,173)	2
	◆ 31952	EPDM	◆ 31952	EPDM	◆ 31952	EPDM	Kit, Valve, Preassembled (Incls: 162,163,164,166,167,168,170,172,173)	2
—	819000	F	819000	F	819000	F	Assy, Crankcase, Cast Iron Conversion	1
390	714500	SS	714500	SS	714500	SS	C.A.T. (Inlet pressure stabilizer for RO and boosted inlet applications)	1
391	714506	SS	714506	SS	714506	SS	Adapter (2 per C.A.T.) (See Data Sheet for complete selection)	2
392	701828	SS	701828	SS	701828	SS	Elbow Assy used with Adapter Assy 714506	1
—	6575	—	6575	—	6575	—	Plunger Pump Service DVD	1
—	6100	—	6100	—	6100	—	Oil, Case (12 Bottles) ISO -68 Hydraulic (Fill to specified crankcase capacity prior to start-up)	1
—	—	—	6119	—	—	—	Lubricant, Antiseize (1oz) (See Tech Bulletin 095)	1

**Bold print part numbers are unique to a particular pump model. Italics are optional items. [ ]** Date of latest production change.

◆ Silicone oil/grease required. † Production parts differ from service parts.\* Review individual parts in each kit for material identification. R Components comply with RoHS Directive

**C.A.T. highly recommended for pressurized inlet, R.O. and Industrial applications.**

View Tech Bulletins 03, 024, 035, 036, 040, 041, 043, 050, 052, 053, 069, 074, 077, 083, 095, 099, 105, 108 and 109 for additional information.

MATERIAL CODES (Not Part of Part Number): ABS=ABS Plastic AL=Aluminum BB=Brass BCCP=Brass/Chrome Plated CC=Ceramic CM=Chrome-Moly D=Acetal  
 EPDM=Ethylene Propylene Diene Monomer F=Cast Iron FBB=Forged Brass FBR=Fiber FCM=Forged Chrome-moly FPM=Fluorocarbon NAB=Nickel Aluminum Bronze  
 NBR=Medium Nitrile (Buna-N) NBRSS=Buna, Silicone Free NY=Nylon POP=Polypropylene PTFE=Pure Polytetrafluoroethylene PVDF=Polyvinylidene Fluoride S=304SS SS=316SS  
 SSD=Duplex Stainless Steel SSL=316/Low Carbon SSZZ=316SS/Zamak STCP=Steel/Chrome Plated STG=Special Blend (FPM) STG=Special Blend (PTFE) White  
 STL=Steel STZP=Steel/Zinc Plated TNM=Special High Strength ZP=Zinc Plated

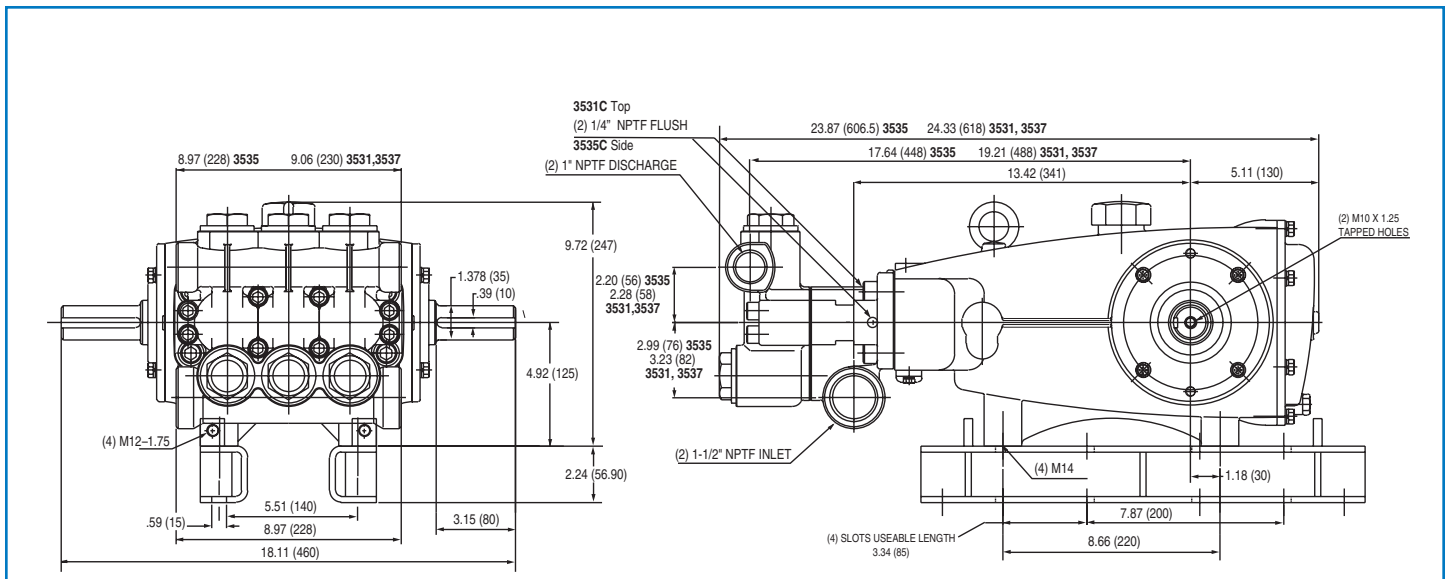

Models 3535, 3535C, 3531, 3531C, 3537

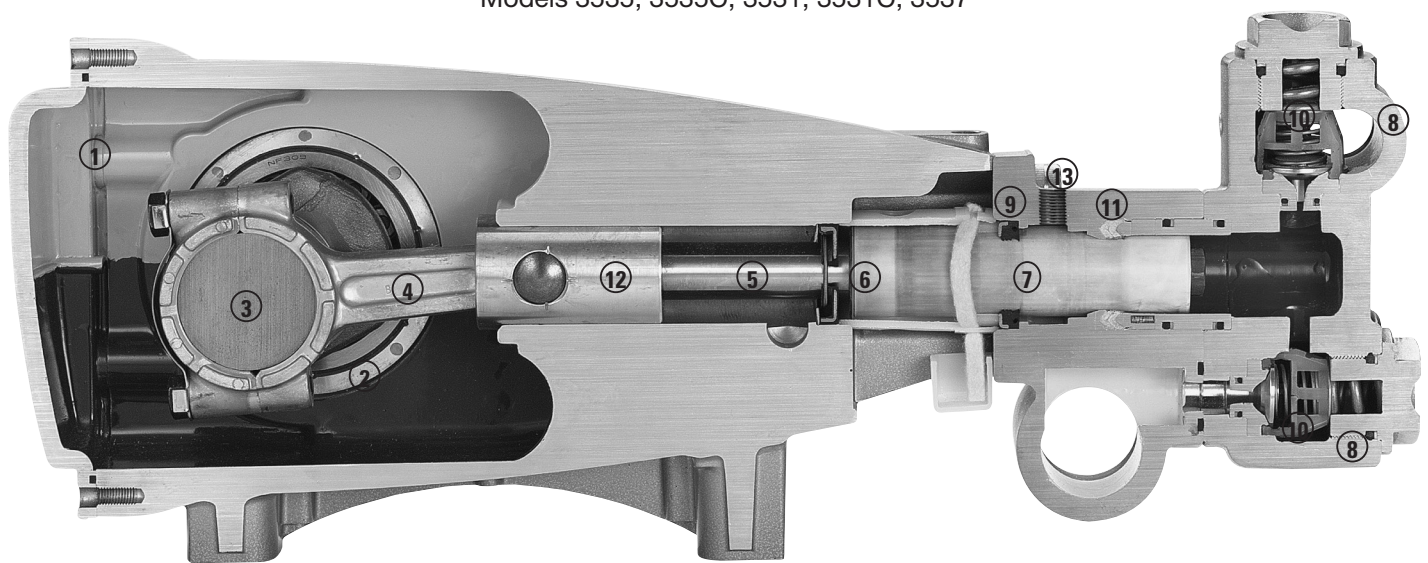

- 1 Die cast aluminum **crankcase** means high strength, lightweight, and excellent tolerance control.
- 2 Oversized crankshaft **bearings** provide extended bearing life and pump performance.
- 3 Chrome-moly **crankshaft** provides unmatched strength and surface hardness for long life.
- 4 Matched oversized TNM **connecting rods** noted for superior tensile strength and bearing quality.
- 5 Special stainless steel **plunger rods** with high strength crossheads for longevity and corrosion resistance.
- 6 The stainless steel **slinger** provides back-up protection for the crankcase seal, keeping pumped liquids out of the crankcase.
- 7 Special concentric, high-density, polished, solid ceramic **plungers** provide a true wear surface and extended seal life.
- 8 **Manifolds** are a high tensile strength forged brass, 316 stainless steel, duplex stainless or nickel aluminum bronze for long term, continuous duty.
- 9 100% wet **seal** design adds to service life by allowing pumped liquids to cool and lubricate on both sides.
- 10 Stainless steel **valves, seats and springs** provide corrosion-resistance, ultimate seating and extended life.
- 11 Specially formulated, Cat Pump exclusive, **V-Packings** offer unmatched performance and seal life.
- 12 **Crossheads** are 360° supported providing uncompromising alignment.
- 13 Special **Flushed Inlet Manifold** permits external flush for added cooling with high temperature liquids and lubrication with low lubricity liquids.

### World Headquarters

Cat Pumps

1681 - 94th Lane N.E. Minneapolis, MN 55449 - 4324

Phone (763) 780-5440 — FAX (763) 780-2958

e-mail: techsupport@catpumps.com

www.catpumps.com

### International Inquiries

FAX (763) 785-4329

e-mail: intlsales@catpumps.com



The Pumps with Nine Lives

### CAT PUMPS (U.K.) LTD.

1 Fleet Business Park, Sandy Lane, Church Crookham

FLEET, Hampshire, GU52 8BF, England

Phone Fleet 44 1252-622031 — Fax 44 1252-626655

e-mail: sales@catpumps.co.uk www.catpumps.co.uk

### N.V. CAT PUMPS INTERNATIONAL S.A.

Heiveldekens 6A, B-2550 Kontich, Belgium

Phone 32-3-450.71.50 — Fax 32-3-450.71.51

e-mail: cpi@catpumps.be www.catpumps.be

### CAT PUMPS DEUTSCHLAND GmbH

Buchwiese 2, D-65510 Idstein, Germany

Phone 49 6126-9303 0 — Fax 49 6126-9303 33

e-mail: catpumps@t-online.de www.catpumps.de