

Model 3511 Shown
(Shaft protector included, mounting rails sold sepererately)

35 Frame Plunger Pumps

Stainless Steel Models

3501, 3511

SS Flushed Models

3501C, 3511C

FEATURES

- Triplex design delivers high efficiency and low pulsation.
- Durable custom V-Packings are lubricated and cooled by pumped liquid.
- Pre-set Lo-Pressure Seals provide secondary protection against external leaks and require no packing adjustments.
- Special high-density, polished, concentric plungers provide a true surface and extended seal life.
- Wet-end easily serviced without entering crankcase.

COMMON SPECIFICATIONS

Inlet Pressure Range	Fllooded to 70 psi	(Fllooded to 4.9 bar)
Stroke	1.890"	(48 mm)
Crankcase Capacity	4.2 Qts.	(4 l)
Maximum Liquid Temperature	160°F	(71°C)
Above 130°F call Cat Pumps for inlet conditions and elastomer recommendations.		
Inlet Ports (2)	1-1/2" NPTF	(1-1/2" NPTF)
Flushing Ports (2) (3501,3501C)	1/4" NPTF	(1/4" NPTF)
Discharge Ports (2) (3501,3511C).....	3/4" NPTF	(3/4" NPTF)
Discharge Ports (2) (3511,3511C).....	1" NPTF	(1" NPTF)
Pulley Mounting.....	Either Side	(Either Side)
Shaft Diameter.....	1.378"	(35mm)
Weight	130.6 lbs.	(59 kg)
Dimensions.....	24.51 x 18.11 x 9.72"	(623 x 460 x 247 mm)

⚠ CAUTIONS AND WARNINGS

All High Pressure Systems require a primary pressure regulating device (i.e. regulator, unloader) and a secondary pressure relief device (i.e. pop-off valve, relief valve). Failure to install such relief devices could result in personal injury or damage to pump or property. CAT PUMPS does not assume any liability or responsibility for the operation of a customer's high pressure system.

Read all CAUTIONS and WARNINGS before commencing service or operation of any high pressure system. The CAUTIONS and WARNINGS are included in each service manual and with each Data sheet. CAUTIONS and WARNINGS can also be viewed online at www.catpumps.com/cautions-warnings or can be requested directly from CAT PUMPS.

WARRANTY

View the Limited Warranty on-line at www.catpumps.com/warranty.

SPECIFICATIONS

U.S. Measure

Metric Measure

Models 3501, 3501C

Flow	9.0 gpm	(34 l/m)
Pressure Range	100 to 5000 psi	(7 to 345 bar)
RPM.....	824 rpm	(824 rpm)
Bore.....	0.787"	(20 mm)

Models 3511, 3511C

Flow	14.0 gpm	(53 l/m)
Pressure Range	100 to 3000 psi	(7 to 210 bar)
RPM.....	800 rpm	(800 rpm)
Bore.....	0.984"	(25 mm)

ELECTRIC HORSEPOWER REQUIREMENTS

MODEL	FLOW		2000	2500	3000	4000	4500	5000	rpm
	gpm	l/m	psi	psi	psi	psi	psi		
3501 3501C	9	34	N/A	N/A	N/A	24.7	27.7	30.8	824
	8	30	N/A	N/A	N/A	21.9	24.7	27.4	711
	7	27	N/A	N/A	N/A	19.2	21.6	24.0	622
3511 3511C	14	53	19.2	24.0	28.8	N/A	N/A	N/A	800
	12	45	16.4	20.6	24.7	N/A	N/A	N/A	685
	10	38	13.7	17.1	20.6	N/A	N/A	N/A	571

**DETERMINING
THE PUMP RPM**

$$\frac{\text{Rated gpm}}{\text{Rated rpm}}$$

$$= \frac{\text{"Desired" gpm}}{\text{"Desired" rpm}}$$

**DETERMINING
THE REQUIRED H.P.**

$$\frac{\text{gpm} \times \text{psi}}{1460}$$

$$= \frac{\text{Electric Brake}}{\text{H. P. Required}}$$

**DETERMINING
MOTOR PULLEY SIZE**

$$\frac{\text{Motor Pulley O.D.}}{\text{Pump rpm}}$$

$$= \frac{\text{Pump Pulley O.D.}}{\text{Motor rpm}}$$

See complete Drive Packages [Incls: Pulleys, Belts, Hubs, Key] Tech Bulletin 003.

Refer to pump **Service Manual** for repair procedure, additional technical information and **pump warranty**.

"Customer confidence is our greatest asset"

PARTS LIST

ITEM	3501	MATL	3511	MATL	DESCRIPTION	QTY
2	34021	STL	34021	STL	Key (M10x8x70)	1
5	125753	S	125753	S	Screw, HH Sems (M8x25)	8
8	44542	AL	44542	AL	Cover, Bearing	2
9	815279	FBR	815279	FBR	Shim, Split, 2 pc	2
10	12398	NBR	12398	NBR	O-Ring, Bearing Cover - 70D	2
11	13296	NBR	13296	NBR	Seal, Oil, Crankshaft	2
15	29326	STL	29326	STL	Bearing, Roller	2
20	126725	BZ	126725	BZ	Rod, Connecting Assy (Incls: 21, 22, 23)	3
21	126749	STCP R	126749	STCP R	Washer, Locking (M10)	3
22	126574	STCP R	126574	STCP R	Washer, Flat (M10)	6
23	122045	STZP	122045	STZP	Screw, HH (M10x55)	6
25	29325	FCM	29325	FCM	Crankshaft, Dual End (M48)	1
31	828710	—	828710	—	Protector, Oil Cap w/Foam Gasket	1
32	43211	ABS	43211	ABS	Cap, Oil Filler	1
33	14177	NBR	14177	NBR	O-Ring, Oil Filler Cap - 70D	1
34	126743	STCP R	126743	STCP R	Bolt, Eye (M12x1.75) (For Lifting Pump Only)	1
37	92241	—	92241	—	Gauge, Bubble Oil w/Gasket - 80D	1
38	44428	NBR	44428	NBR	Gasket, Flat Oil Gauge - 80D	1
40	125753	S	125753	S	Screw, HH Sems (M8x25)	8
48	25625	STCP	25625	STCP	Plug, Drain (1/4"x19BSP)	1
49	23170	NBR	23170	NBR	O-Ring, Drain Plug - 70D	1
50	45936	AL	45936	AL	Cover, Rear	1
51	16612	NBR	16612	NBR	O-Ring, Cover - 70D	1
53	44487	AL	44487	AL	Crankcase Assy (Incls: 34, 54)	1
54	27488	S	27488	S	Pin, Guide	2
56	27790	POP	27790	POP	Pan, Oil	1
59	92538	S	92538	S	Screw, HHC Sems (M6x16)	2
64	43864	CM	43864	CM	Pin, Crosshead	3
65	† 45118	SSZZ	† 45118	SSZZ	Rod, Plunger	3
69	126587	STCP R	126587	STCP R	Washer, Oil Seal	3
70	100488	NBRS	100488	NBRS	Seal, Oil, Crankcase	3
	44739	FPM	44739	FPM	Seal, Oil, Crankcase	3
75	43506	S	43865	S	Slinger, Barrier	3
87	49667	SSL	109608	SS	Collar	3
88	45676	S	45676	S	Washer, Keyhole	3
90	43945	CC	—	—	Plunger (M20x145)	3
	—	—	43866	CC	Plunger (M25x145)	3
95	89779	S	—	—	Stud, Retainer (M7x123)	3
	—	—	89778	SS	Stud, Retainer (M10x135)	3
96	20184	PTFE	20189	PTFE	Back-up-Ring, Plunger Retainer	3
97	14190	NBR	11345	NBR	O-Ring, Plunger Retainer - 70D	3
	14161	FPM	11375	FPM	O-Ring, Plunger Retainer - 70D	3
98	44069	SS	44085	SS	Gasket, Plunger Retainer	3
99	44068	SS	44084	SS	Retainer, Plunger	3
100	814279	PVDF	814279	PVDF	Retainer, Seal, 2 Pc.	3
101	44095	—	44096	—	Wick	3
104	43875	NBR	43875	NBR	O-Ring, Adapter - 70D	3
	44826	FPM	44826	FPM	O-Ring, Adapter - 70D	3
105	701344	SS	113022	SS	Adapter, LPS	3
106	44071	NBR	44086	NBR	Seal, LPS w/SS-Spg	3
	44381	FPM	45846	FPM	Seal, LPS w/SS-Spg	3
107	44074	SS	44089	SS	Washer, LPS	3
110	45365	SS	45365	SS	Manifold, Inlet	1
	125397	SS	125397	SS	Manifold, Inlet, Flushed (1/4" Flush Port)	1
112	11379	NBR	11379	NBR	O-Ring, Inlet Manifold - 70D	3
	14183	FPM	14183	FPM	O-Ring, Inlet Manifold	3
117	44585	S	44585	S	Screw, HSH (M14x40)	4
123	12391	NBR	12391	NBR	O-Ring, V-Packing Cylinder - 70D	3
	13266	FPM	13266	FPM	O-Ring, V-Packing Cylinder - 70D	3
124	49666	SSL	113023	SS	Cylinder, V-Packing	3
126	44164	SS	113024	SS	Adapter, Female	3
127	44607	STG*	—	—	V-Packings	9
	—	—	44610	STG*	V-Packings	6
128	44165	SS	113025	SS	Adapter, Male	3
155	17622	NBR	—	—	O-Ring, V-Packing Spacer - 85D	3
	11719	FPM	—	—	O-Ring, V-Packing Spacer	3
	—	—	11379	NBR	O-Ring, V-Packing Spacer - 70D	6
	—	—	14183	FPM	O-Ring, V-Packing Spacer	6
156	28675	PTFE	—	—	Back-up-Ring, V-Packing Spacer	3
	—	—	28243	PTFE	Back-up-Ring, V-Packing Spacer	6
157	49668	SSL	113026	SS	Spacer, V-Packing	3
159	12390	NBR	—	—	O-Ring, V-Packing Spacer - 70D	3
	13264	FPM	—	—	O-Ring, V-Packing Spacer	3
162	21985	PTFE	21985	PTFE	Back-up-Ring, Seat	6
163	26089	NBR	26089	NBR	O-Ring, Seat - 80D	6
	11377	FPM	11377	FPM	O-Ring, Seat - 80D	6
164	49671	SS	49671	SS	Seat	6
166	44081	SS	44081	SS	Valve	6
167	44082	SS	44082	SS	Spring	6
168	44735	PVDF	44735	PVDF	Retainer, Spring	6
170	44794	SS	44794	SS	Washer, Spring Retainer	6
171	44793	SS	44793	SS	Spring, Coil, Valve Plug	6
172	15853	NBR	15853	NBR	O-Ring, Valve Plug - 70D	6
	11720	FPM	11720	FPM	O-Ring, Valve Plug - 70D	6
173	20224	PTFE	20224	PTFE	Back-up-Ring, Valve Plug	6
174	45603	SS	45603	SS	Plug, Valve	6
175	87951	S	87951	S	Screw, HSH (M10x30)	36
185	49669	SSD	49672	SSD	Manifold, Discharge	1
188	89981	S	89981	S	Screw, HSH (M12x70)	8
250	44516	NY	44516	NY	Protector, Shaft, w/2 Screws, Washers, Lockwashers	1
255	34018	STZP R	34018	STZP R	Assy, Direct Mount	1
	34039	S	34039	S	Assy, Direct Mount	1
260	92674	STZP R	92674	STZP R	Mounting, Rail, Assy (Incls: 34018)	1

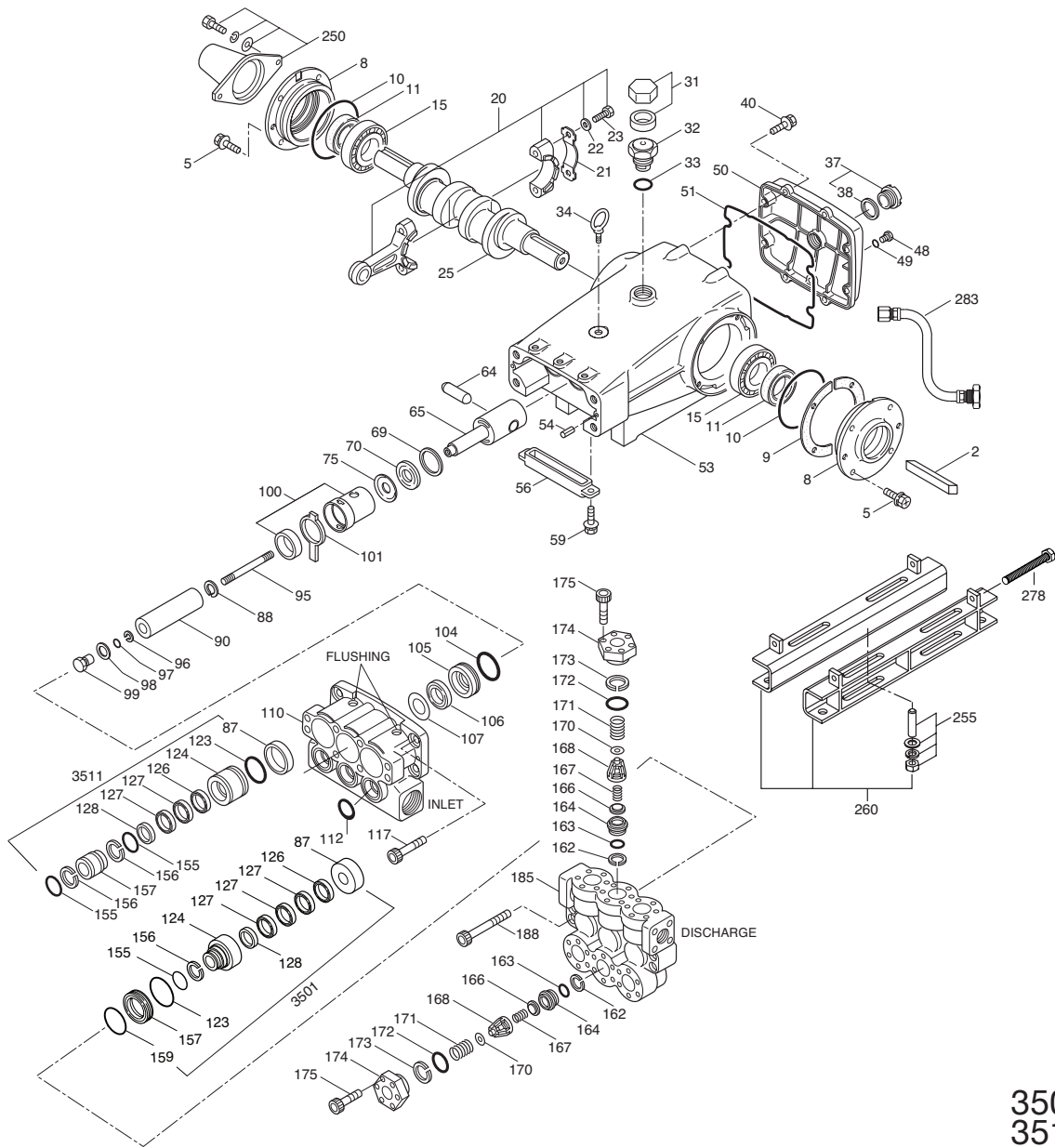

Models
3501, 3501C
3511, 3511C
March 2010

ITEM	3501	MATL	3511	MATL	DESCRIPTION	QTY
275	990013	STL	990013	STL	Hub, 'B' 35mm w/Keyway (See Tech Bulletin 003)	1
278	80540	ZP	80540	ZP	Screw, HH (M12x100) (Rail Adjusting Screw)	1
279	30278	STZP	30278	STZP	Oiler (1 oz.) (Not Shown)	3
281	30967	—	30967	—	Glass, Oiler (Not Shown)	3
282	10069	NBR	10069	NBR	Gasket, Oiler (Not Shown)	3
283	34314	—	34314	—	Kit, Oil Drain (3/8" x 48")	1
290	6124	—	6124	—	Gasket, Liquid (3 oz.)	1
299	818459	SS	818438	SS	Head, Complete	1
300	76037	NBR*	—	—	Kit, Seal (Incls: 97,104,106,112,123,127,155,156,159)	1
	76235	FPM*	—	—	Kit, Seal (Incls: 97,104,106,112,123,127,155,156,159)	1
	—	—	31038	NBR*	Kit, Seal (Incls: 97,104,106,112,123,127,155,156)	1
	—	—	31266	FPM*	Kit, Seal (Incls: 97,104,106,112,123,127,155,156)	1
310	76251	NBR	76251	NBR	Kit, Valve (Incls: 162,163,164,166,167,168,170,172,173)	2
	76798	FPM	76798	FPM	Kit, Valve (Incls: 162,163,164,166,167,168,170,172,173)	2
390	711500	SS	711500	SS	C. A. T. (Inlet pressure stabilizer for RO and boosted inlet applications)	1
391	711506	SS	711506	SS	Adapter (2 per C.A.T.) (See Data Sheet for complete selection)	2
392	701818	SS	701818	SS	Elbow Assy used with Adapter Assy 711506	1
—	819000	F	819000	F	Assy, Crankcase, Cast Iron Conversion	1
—	6119	—	6119	—	Lubricate, Antisieze (1 oz.) (See Tech Bulletin 095)	1
—	6575	—	6575	—	Plunger Pump Service DVD	1
—	6100	—	6100	—	Oil, Case (12 Bottles) ISO-68 Hydraulic	1

Bold print part numbers are unique to a particular pump model. Italics are optional items. [] Date of latest production change. R Components comply with RoHS Directive.

*Review individual parts in each kit for material code identification. Veiv Tech Bulletins 002, 003, 024, 035, 036, 041, 043, 052, 053, 068, 069, 074, 077, 080,083 and 095 for additional information.

C.A.T. highly recommended for pressurized inlet, R.O. and Industrial applications. MATERIAL CODES (Not Part of Part Number): ABS=ABS Plastic AL=Aluminum BB=Brass BZ=Bronze BCCP=Brass/Chrome Plated CC=Ceramic CM=Chrome-Moly F=Cast Iron FBR=Fiber FCM=Forged Chrome-moly FPM=Fluorocarbon NAB=Nickel Aluminum Bronze NBR=Medium Nitrile (Buna-N) NBRs=Buna, Silicone Free NY=Nylon POP=Polypropylene PTFE=Pure Polytetrafluoroethylene PVDF=Polyvinylidene FluorideS=304SS SS=316SS SSL=316SS/Low Carbon STG=Special Blend PTFE White SSZZ=316SS/Zamak STL=Steel STCP=Steel/Chrome Plated STZP=Steel/Zinc Plated ZP=Zinc Plated

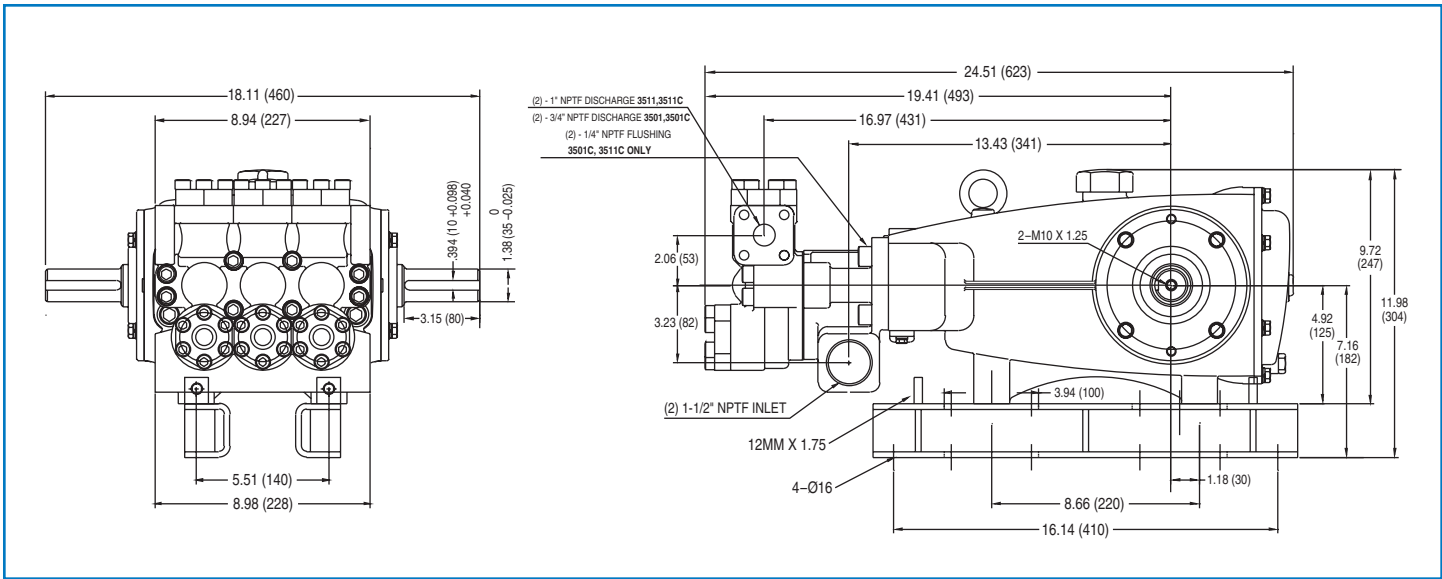

Models 3501, 3501C, 3511, 3511C

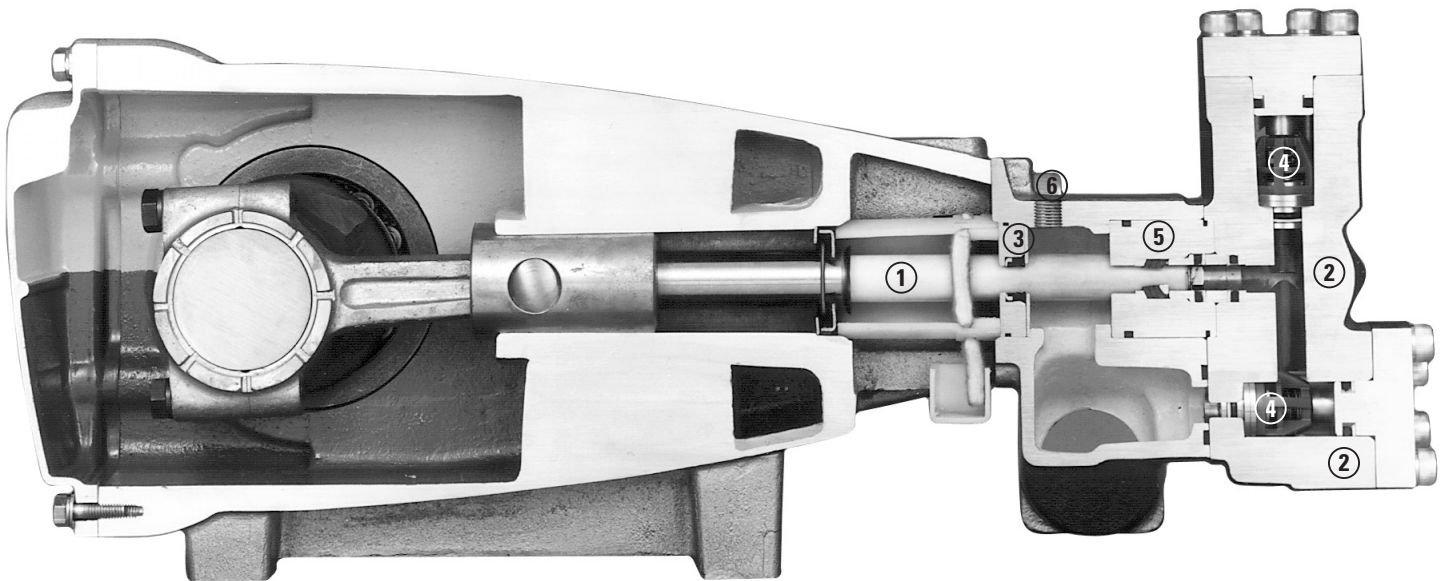

- 1 Special concentric, high-density, polished, solid ceramic **plungers** provide a true wear surface and extended seal life.
- 2 **Manifolds** are high tensile strength 316 stainless steel for long term, continuous duty.
- 3 100% wet **seal** design adds to service life by allowing pumped liquids to cool and lubricate on both sides.
- 4 Stainless steel **valves, seats and springs** provide corrosion-resistance, ultimate seating and extended life.
- 5 Specially formulated, Cat Pump exclusive, **V-Packings** offer unmatched performance and seal life.
- 6 Special **Flushed Inlet Manifold** permits external flush for adding cooling with high temperature liquids and lubrication with low lubricity liquids.

World Headquarters

Cat Pumps

1681 - 94th Lane N.E. Minneapolis, MN 55449 - 4324

Phone (763) 780-5440 — FAX (763) 780-2958

e-mail: techsupport@catpumps.com

www.catpumps.com

International Inquiries

FAX (763) 785-4329

e-mail: intlsales@catpumps.com



The Pumps with Nine Lives

CAT PUMPS (U.K.) LTD.

1 Fleet Business Park, Sandy Lane, Church Crookham

FLEET, Hampshire, GU52 8BF, England

Phone Fleet 44 1252-622031 — Fax 44 1252-626655

e-mail: sales@catpumps.co.uk www.catpumps.co.uk

N.V. CAT PUMPS INTERNATIONAL S.A.

Heiveldekens 6A, B-2550 Kontich, Belgium

Phone 32-3-450.71.50 — Fax 32-3-450.71.51

e-mail: cpi@catpumps.be www.catpumps.be

CAT PUMPS DEUTSCHLAND GmbH

Buchwiese 2, D-65510 Idstein, Germany

Phone 49 6126-9303 0 — Fax 49 6126-9303 33

e-mail: catpumps@t-online.de www.catpumps.de