

DATA SHEET

25 FRAME PLUNGER PUMPS



Brass

2530, 2530E

Stainless Steel

2531

Flushed Stainless Steel

2531C

Nickel Aluminum Bronze

2537

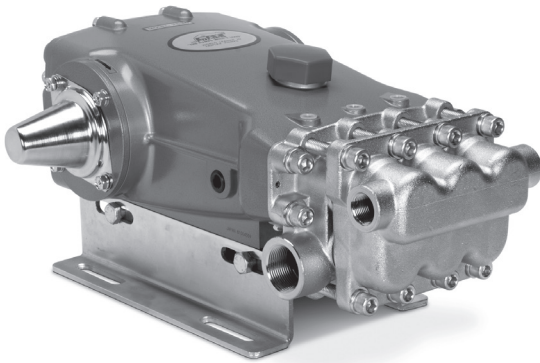

Model 2530 Shown
(Shaft protector and mounting rails sold separately)

COMMON SPECIFICATIONS

	U.S.	Metric
Flow	25 gpm	95 lpm
Pressure Range	100 to 1200 psi	6.9 to 83 bar
Pump RPM*	1025 rpm	1025 rpm
Inlet Pressure Range	Flooded to 70 psi	Flooded to 4.8 bar
Max. Liquid Temp. (NBR)	160° F	71° C
Alternative seals available for high temp up to 200° F		
Bore	1.260"	32 mm
Stroke	1.516"	38.5 mm
Crankcase Capacity	84 oz.	2.5 l
Inlet Ports (2)	1 1/4" NPT(F)	1 1/4" NPT (F)
Flush Ports (2)	1/4" NPT (F)	1/4" NPT (F)
Discharge Ports (2)	3/4" NPT (F)	3/4" NPT (F)
Pulley Mounting	Either Side	Either Side
Shaft Diameter	1.181"	30 mm
Weight	68.3 lbs.	31 kg
Dimensions	19.43 x 15.04 x 7.8"	493 x 382 x 198 mm

*Pump minimum is 100 RPM.

FEATURES

- Triplex design delivers high efficiency and low pulsation.
- Durable high pressure seals are lubricated and cooled by pumped liquid.
- Pre-set Lo-Pressure seals provide secondary protection against external leaks and require no packing adjustments.
- Standard NBR seals with alternative options for temperature and chemical compatibility.

ALTERNATIVE SEAL CONFIGURATION

MATERIAL	SUFFIX CODE	MAXIMUM TEMPERATURE	
NBR	—	160° F	(71° C)
FPM	.0110	180° F	(82° C)
EPDM	.0220	160° F	(71° C)
IPFE	.0770	200° F	(93° C)
HT	.3000	180° F	(82° C)
STHT	.3400	190° F	(88° C)

See Reference Document 99TCH002 for inlet conditions and RPM at high temperature.

$$\text{DETERMINING THE PUMP R.P.M.} \quad \frac{\text{Rated gpm}}{\text{Rated rpm}} = \frac{\text{"Desired" gpm}}{\text{"Desired" rpm}}$$

$$\text{DETERMINING THE REQUIRED H.P.} \quad \text{Hp (Electric Brake)} = \frac{\text{gpm} \times \text{psi}}{1460}$$

$$\text{DETERMINING MOTOR PULLEY SIZE} \quad \frac{\text{Motor Pulley O.D.}}{\text{Pump rpm}} = \frac{\text{Pump Pulley O.D.}}{\text{Motor rpm}}$$

Refer to pump **Service Manual** for repair procedure and additional technical information.

PARTS LIST

ITEM	PART		PART		PART		DESCRIPTION	QTY
	NUMBER	MATL	NUMBER	MATL	NUMBER	MATL		
	2530, 2530E		2531, 2531C		2537			
5	126544	STCP R	125753	S	125753	S	Screw, HHC, Sems (M8x25)	8
	125753	S	—	—	—	—	Screw, HHC, Sems (M8x25) (Model 2530E)	8
8	49533	ALE	49533	ALE	49533	ALE	Cover, Bearing (See Tech Bulletin 118)	2
10	27772	NBR	27772	NBR	27772	NBR	O-Ring, Oil Seal Case - 70D	2
11	27771	NBR	27771	NBR	27771	NBR	Seal, Oil, Crankshaft - 70D	2
15	26512	STL	26512	STL	26512	STL	Bearing, Ball	2
20	48613	TNM	48613	TNM	48613	TNM	Rod, Connecting	3
21	126562	STCP R	126562	STCP R	126562	STCP R	Washer, Locking	3
25	49795	FCM	49795	FCM	49795	FCM	Crankshaft - Dual End [3/11]	1
31	828710	PE	828710	PE	828710	PE	Protector, Oil Cap w/Gasket	1
32	43211	ABS	43211	ABS	43211	ABS	Cap, Oil Filler	1
33	14177	NBR	14177	NBR	14177	NBR	O-Ring, Oil Filler Cap -70D	1
36	129343	RBR	129343	RBR	129343	RBR	Gasket, Flat	1
37	92241	PC	92241	PC	92241	PC	Gasket, Oil, Bubble w/ Gasket - 80D	1
38	44428	NBR	44428	NBR	44428	NBR	Gasket, Flat, Oil Gauge - 80D	1
39	27769	ABS	27769	ABS	27769	ABS	Dipstick	1
40	126544	STCP R	125753	S	125753	S	Screw, HHC, Sems (M8x25)	8
	125753	S	—	—	—	—	Screw, HHC, Sems (M8x25) (Model 2530E)	8
48	25625	STCP	25625	STCP	25625	STCP	Plug, Drain (1/4"x19BSP)	1
49	23170	NBR	23170	NBR	23170	NBR	O-Ring, Drain Plug -70D	1
50	133582	ALE	133582	ALE	133582	ALE	Cover, Rear (See Tech Bulletin 118 and 126)	1
51	27767	NBR	27767	NBR	27767	NBR	O-Ring, Rear Cover - 70D	1
53	49528	ALE	49528	ALE	49528	ALE	Crankcase w/Guide Pins (See Tech Bulletin 118)	1
54	27488	S	27488	S	27488	S	Pin, Guide	2
56	27790	POP	27790	POP	27790	POP	Pan, Oil	1
59	125824	STCP R	92538	S	92538	S	Screw, HHC, Sems (M6x16)	2
	92538	S	—	—	—	—	Screw, HHC, Sems (M6x16) (Model 2530E)	2
64	27784	CM	27784	CM	27784	CM	Pin, Crosshead	3
65	† 48719	SSHS	48719	SSHS	48719	SSHS	Rod, Plunger	3
70	27785	NBR	27785	NBR	27785	NBR	Seal, Crankcase Oil -70D	3
75	110669	S	110669	S	110669	S	Slinger, Barrier	3
88	110670	S	110670	S	110670	S	Washer, Keyhole	3
90	45749	CC	45749	CC	45749	CC	Plunger (M32x93)	3
95	† 89835	SS	89835	SS	89835	SS	Stud, Retainer (M7x87)	3
96	20184	PTFE	20184	PTFE	20184	PTFE	Back-up-Ring, Plunger Retainer	3
97	14190	NBR	14190	NBR	14190	NBR	O-Ring, Plunger Retainer - 70D	3
98	44069	SS	44069	SS	44069	SS	Gasket, Plunger Retainer	3
99	44068	SS	44068	SS	44068	SS	Retainer, Plunger (M7) [7/02]	3
100	49788	NY	49788	NY	49788	NY	Retainer, LPS, Front	3
	49789	NY	49789	NY	49789	NY	Retainer, LPS, Rear	3
101	110796	—	110796	—	110796	—	Wick, Long Tab (M32)	3
106	† 44098	NBR	† 44098	NBR	† 44098	NBR	Seal, LPS w/SS-Spg	3
110	49265	CFBB	48583	SS	45830	NAB	Manifold, Inlet	1
	—	—	49545	SS	—	—	Manifold, Inlet Flushed (1/4" Ports)	1
116	126570	STCP R	19085	S	19085	S	Lockwasher, Split	4
	19085	S	—	—	—	—	Lockwasher, Split (Model 2530E)	4
117	126518	STCP R	88398	S	88398	S	Screw, HSH (M12x40)	4
	88398	S	—	—	—	—	Screw, HSH (M12x40) (Model 2530E)	4
125	† 45832	SNG	45832	SNG	45832	SNG	Seal, HPS w/SS	3
143	14203	NBR	14203	NBR	14203	NBR	O-Ring, Adapter, LPS, Rear-70D	3
150	45752	BB	45835	SS	45835	SS	Adapter, LPS	3
154	18690	NBR	18690	NBR	18690	NBR	O-Ring, Adapter, LPS, Front -70D	3
155	14520	NBR	14520	NBR	14520	NBR	O-Ring, Adapter, Valve -70D	6
157	45751	BB	45834	SS	45834	SS	Adapter, Valve	3
164	† 46857	SS	46857	SS	46857	SS	Seat [11/95] (See Tech Bulletin 076)	6
165	14014	NBR	14014	NBR	14014	NBR	O-Ring, Seat	6
166	† 45839	SS	45839	SS	45839	SS	Valve	6
167	† 45840	SS	45840	SS	45840	SS	Spring	6
168	110682	PVDF	110682	PVDF	110682	PVDF	Retainer, Spring	6
185	49267	CFBB	48585	SS	45836	NAB	Manifold, Discharge	1
186	126570	STCP R	19085	S	19085	S	Lockwasher, Split	8
	19085	S	—	—	—	—	Lockwasher, Split (Model 2530E)	8
188	126517	STCP R	89628	S	89628	S	Screw, HSH (M12x65)	8
	89628	S	—	—	—	—	Screw, HSH (M12x65) (Model 2530E)	8

Bold print part numbers are unique to a particular pump model. Italics are optional items. [] Date of latest production change.

◆ Silicone oil/grease required. † Production parts are different than repair parts. R Components comply with RoHS Directive.

For additional technical information see www.catpumps.com/literature/tech-bulletins. MATERIAL CODES (Not Part of Part Number):

ABS=ABS Plastic ALE=Aluminum Epoxy BB=Brass CC=Ceramic CFBB=Chrome Forged Brass CM=Chrome-moly EPDM=Ethylene Propylene Diene Monomer

F=Cast Iron FCM=Forged Chrome-moly FPM=Fluorocarbon HT=High Temp (EPDM Alternative) IPFE=I-Perfluoroelastomer NAB=Nickel Aluminum Bronze

NBR=Medium Nitrile (Buna-N) NY=Nylon PC=Poly Carbonate PE=Polyethylene POP=Polypropylene PTFE=Pure Polytetrafluoroethylene

PVDF=Polyvinylidene Fluoride S=304SS SS=316SS SNG=Special Blend (Buna) ST2=Special PTFE2 STL=Steel SSHS=316SS/High Strength

STCP=Steel/Chrome Plated STHT=Special PTFE High Temp STZP=Steel/Zinc Plated TNM=Special High Strength

Standard and optional Seal Kits and Valve Kits listed on pages 3 and 4. Optional Parts and Accessories and Service parts listed on Page 3.

EXPLODED VIEW

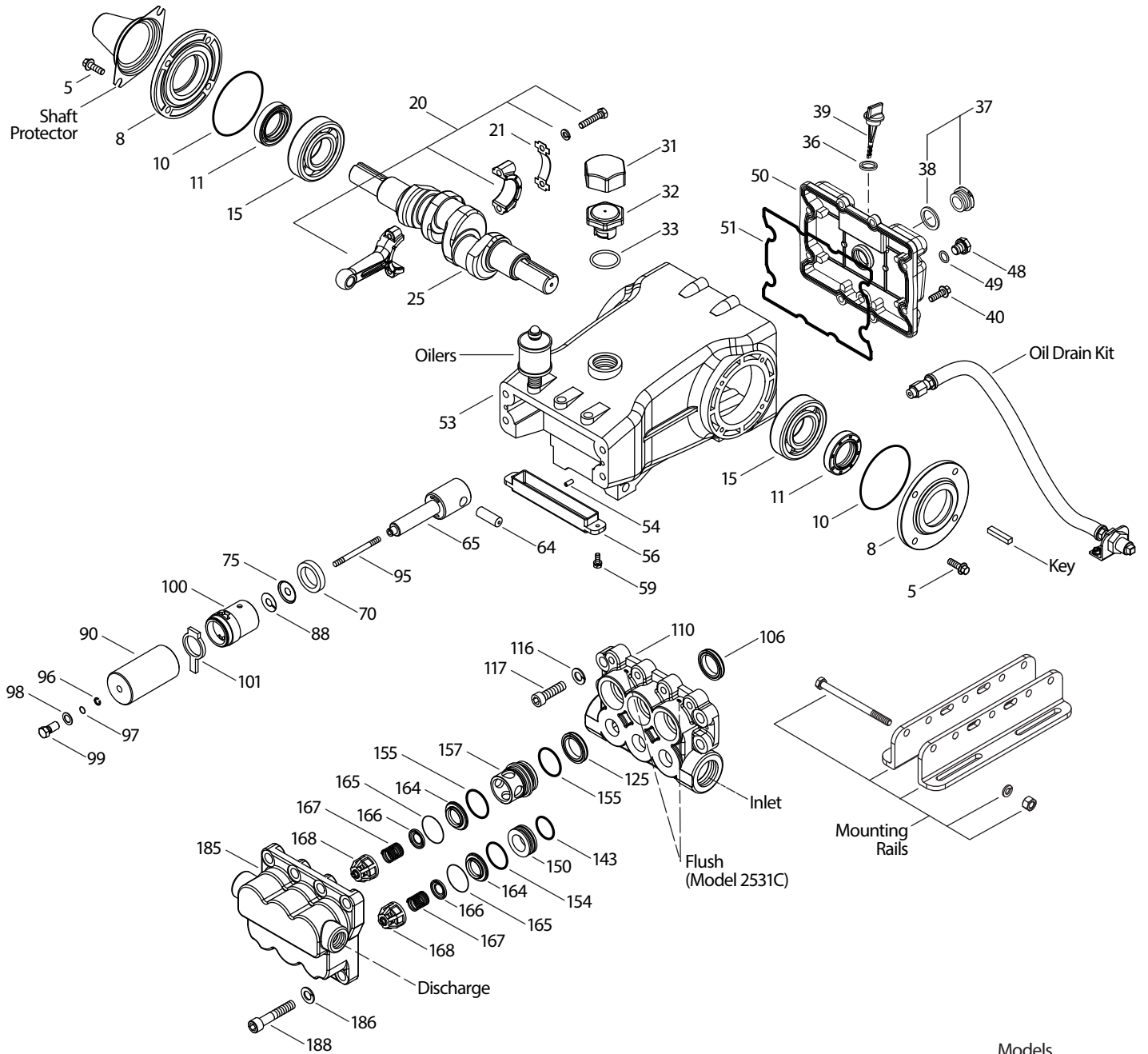

Models
 Brass - 2530, 2530E
 Stainless Steel - 2531, 2531C
 Nickel Aluminum Bronze - 2537
 January 2020

OPTIONAL PARTS AND ACCESSORIES

PART	DESCRIPTION	QTY
990036	Key, M8 x 7 x 40	1
30614	Mount, Rail Assembly	1
26516	Protector, Shaft	1
30278	Oiler (1 oz)	3
34334	Kit, Oil Drain (3/8" x 24")	1
30696	Plier, Reverse	1

SERVICE PARTS

PART	DESCRIPTION	QTY
30952	Seal Kit - Standard NBR	1
33952	Valve Kit - Standard NBR	2
6107	Oil, Bottle (21 oz. bottle)	4
6119	Lubricant, Anti-Seize (2 oz) (2531, 2531C)	1
6124	Gasket, Liquid (3 oz)	1
701931	Sealant, Silicone (3 oz) (2530E)	1
814838	Head, Complete - 2530 w/NBR Seals and O-Rings	1
816735	Head, Complete - 2531 w/NBR Seals and O-Rings	1
816538	Head, Complete - 2537 w/NBR Seals and O-Rings	1

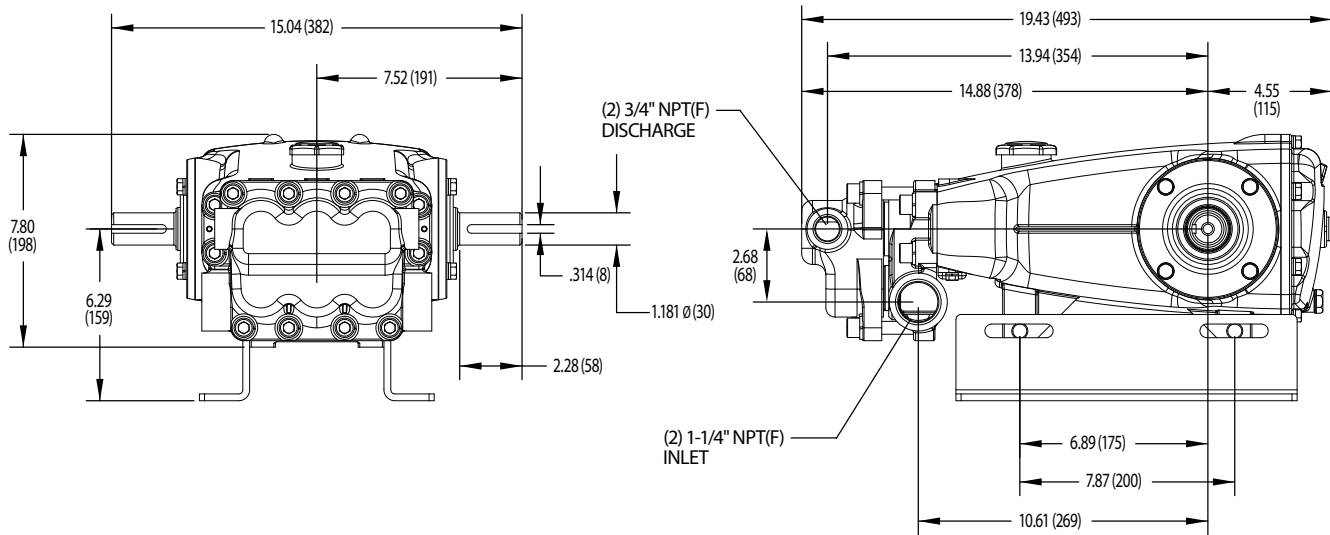

Models 2530, 2530E, 2531, 2537

SEAL KITS One (1) seal kit required per pump

PUMP MODELS	NBR (STD)	FPM (.0110)	EPDM (.0220)◆	STHT (.3400)	IPFE (.0770)
2530, 2530E, 2531, 2531C, 2537	30952	33607	33608	76292	31257*

ITEM (Included in Seal Kits)						DESCRIPTION	QTY
97	14190	14161	48239	14190	703586	O-Ring, Plunger Retainer	3
106	44098	44827	48244	76298	76298	Seal, LPS w/SS-Spg	3
125	45832	48220	48220	48220	48220	Seal, HPS w/SS	3
143	14203	11731	48241	14203	701851	O-Ring, Adapter, LPS Rear	3
154	18690	11744	48242	18690	703588	O-Ring, Adapter, LPS Front	3
155	14520	11745	48240	14520	702962	O-Ring, Adapter, Valve	6

◆ Silicone oil/grease required *Review material codes for individual items (STG generally by be used as alternative)

VALVE KITS Two (2) valve kits required per pump

PUMP MODELS	NBR (STD)	FPM (.0110)	EPDM (.0220)◆
2530, 2530E, 2531, 2531C, 2537	33952	31267	31268

ITEM (Included in Valve Kits)				DESCRIPTION	QTY
143	14203	11731	48241	O-Ring, Adapter, LPS Rear	3
154	18690	11744	48242	O-Ring, Adapter, LPS Front	3
155	14520	11745	48240	O-Ring, Adapter, Valve	6
164	46857	46857	46857	Seat	3
165	14014	48238	48243	O-Ring, Seat	3
166	45839	45839	45839	Valve	3
167	45840	45840	45840	Spring	3
168	110682	110682	110682	Retainer, Spring	3

◆ Silicone oil/grease required

⚠ CAUTIONS AND WARNINGS

All High-Pressure Systems require a primary pressure regulating device (i.e. regulator, unloader) and a secondary pressure relief device (i.e. pop-off valve, relief valve). Failure to install such relief devices could result in personal injury or damage to pump or property. Cat Pumps does not assume any liability or responsibility for the operation of a customer's high pressure-system.

Read all CAUTIONS and WARNINGS before commencing service or operation of any high-pressure system. The CAUTIONS and WARNINGS are included in each Service Manual and with each Accessory Data sheet. CAUTIONS and WARNINGS can also be viewed online at www.catpumps.com/cautions-warnings or can be requested directly from Cat Pumps.

WARRANTY

View the Limited Warranty on-line at www.catpumps.com/warranty.