



CONE JET SPRAY NOZZLE type C

Cone jet spray nozzles can deliver any pressurized liquid.

Cone jet spray nozzles are indicated by the letter C and draw on the surface covered by the jet the approximate shape of an oval that can be full, hollow or eccentric.

The definition “eccentric spray nozzle” is due to the the liquid outlet orifice has an eccentric position with respect to the spray nozzle body axis.

The spray nozzle jet shape depends on the pressure of the sprayed liquid, on the distance between the nozzle and the surface to protect and on the jet spray angle.

In general jet is not cleanly circumscribed on the surface to be protected as several factors such as machining tolerance, wear and atmospheric conditions, can affect the jet.

SPRAY ANGLE

Usually spray angle changes from 45° to 160° according to the spray nozzle type and the required performance.

Jet spray angle depends on viscosity of the liquid and air turbulence.

Angle values have been measured while spray nozzles were delivering water at 20°C.

SPRAY NOZZLE MATERIAL

Caccialanza spray nozzles are in steel, brass, bronze, cast iron, PVC and any plastic material according to the different applications.

Selection of the material to be used depends on the liquid to be sprayed.

PIPE FLOWRATE

It is known that pressure drops increase with pumped liquid speed.

In order to reduce pressure drops, pipe sizes have to be defined considering a liquid speed between 2 and 3 m/sec.

CACCIALANZA SPRAY NOZZLE FLOWRATE

Flowrate of all types of spray nozzles depends exclusively on the diameter of the nozzle pipe independently of the model.

This means that size does not affect flowrate.

Flowrates are calculated with water at 20°C and can change depending on conditions of the jet and of the lines the spray nozzles are mounted on.

Dimensioning a dry powder system pressure upstream the spray nozzle has to be considered.

SIZE OF THE DELIVERED LIQUID DROPS

Size of the very small drops of the liquid delivered by the nozzles depends on nozzle orifice diameter, delivery pressure and angle configuration.

Caccialanza spray nozzles are designed to get a drop scattering on a rather small surface.

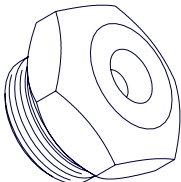
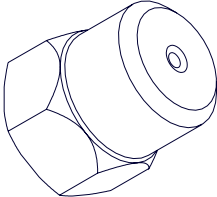

FEATURES OF CONE JET SPRAY NOZZLES

Type	Description	
CP	It consists of a hexagonal body with internal cylinder, with helicoidal grooves, with a central hole ensuring regular and uniform full cone jet. Spray angle is 45°- 60°- 90°. Spray nozzle threading: male.	
CPM	Features are similar to the above ones, but with additional, female threaded coupling. This spray nozzle provides FULL cone jet.	

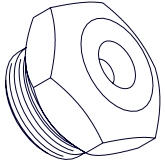
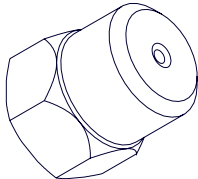

FEATURES OF CONE JET SPRAY NOZZLES

Type	Description	
CC	<p>Features are similar to the CP ones, but without central hole on the internal grooved cylinder. The absence of this hole ensures HOLLOW cone jet. Spray angle is 90°. Spray nozzle threading is male for sizes from 3 to 6 or female for sizes from 0 to 2.</p>	
C CX	<p>Same type as CC but with higher flowrate as the internal cylinder has more helicoidal grooves.</p>	

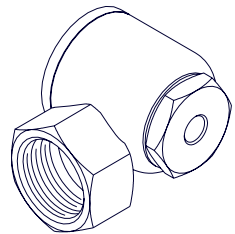
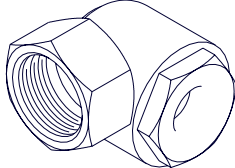
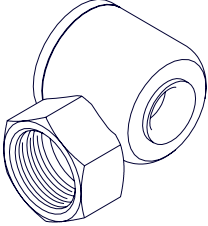
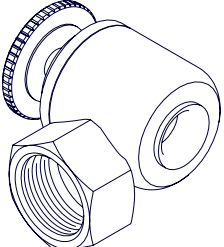

FEATURES OF CONE JET SPRAY NOZZLES

Type	Description	
CEa	<p>It consists of a cast body with cover and threaded nozzle. Spray angle is 60°, but if the outlet orifice is longer than 4 mm, spray angle becomes 90° with HOLLOW cone jet. Spray nozzle threading: female.</p>	
CEb	<p>The spray nozzle consists of two components: cast body and cover with the outlet orifice. Spray angle is 130° with HOLLOW cone jet. Spray nozzle threading: female.</p>	
CEc	<p>Features are similar to the above ones but with fixed orifice and screwed cover. HOLLOW cone jet is obtained. Spray angle is 130°</p>	
CEr	<p>Features are similar to CEc ones but with adjustable flowrate. Decreasing flowrate, spray angle is 100°. HOLLOW cone jet is obtained and orifice can be cleaned.</p>	

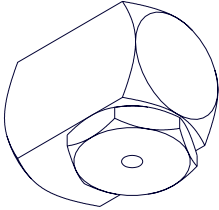
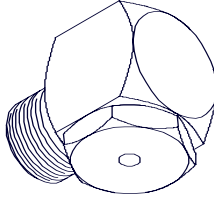
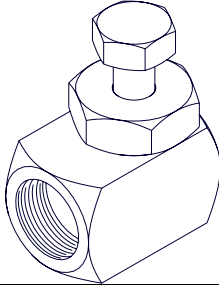

FEATURES OF CONE JET SPRAY NOZZLES

Type	Description	
CN	<p>It consists of a body obtained from a block with threaded nozzle. Spray angle is from 60° to 160° with HOLLOW cone jet. Spray nozzle threading: female.</p>	
CNm	<p>Similar to the previous one with body obtained from a block with cover and threaded nozzle. Spray angle is 60° and 90° with HOLLOW cone jet. Spray nozzle threading: male.</p>	
CNr	<p>Similar to type CN but with adjustable flowrate and allowing orifice cleaning. Decreasing flowrate, spray angle is 60° and 90°. HOLLOW cone jet is obtained. Spray nozzle threading: female.</p>	



DESIGNATION EXAMPLE

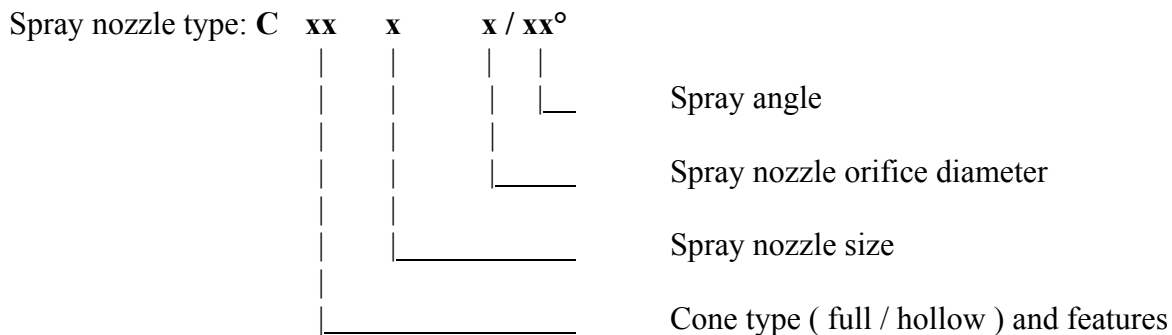

- Size:
- 0** - 1/8"
 - 1** - 3/8"
 - 2** - 1/2"
 - 3** - 3/4"
 - 4** - 1"
 - 5** - 1-1/4"
 - 6** - 1-1/2"
 - 8** - 2"
 - 10** - 2-1/2"
 - 12** - 3"
 - 14** - 3-1/2"
 - 16** - 4"

Spray nozzle orifice diameter: defined by manufacturer

- Spray angle:
- 45°** (CP – CPM)
 - 60°** (CP – CPM – CEa – CN – CNm – CNr)
 - 80°** (CN)
 - 90°** (CP – CPM - CC – CCX – CEa – CNm – CNr)
 - 100°** (CEr)
 - 120°** (CP – CPM – CN)
 - 130°** (CEb – CEc)
 - 160°** (CN)

Designation examples:

- Full cone jet spray nozzle, required flowrate 18.0 l/min. at 4 bar, threading 3/8" male, spray angle 60°

Model: **C P 1 4.4 / 60°**

- Hollow cone jet spray nozzle, body from a block with adjustable flowrate, required flowrate max 12.0 l/min. at 6 bar, with female threaded coupling 1/2", spray angle 90°

Model: **C Nr 2 6 / 90°**



FULL CONE JET SPRAY NOZZLE (CP – CPM)

Dimensions

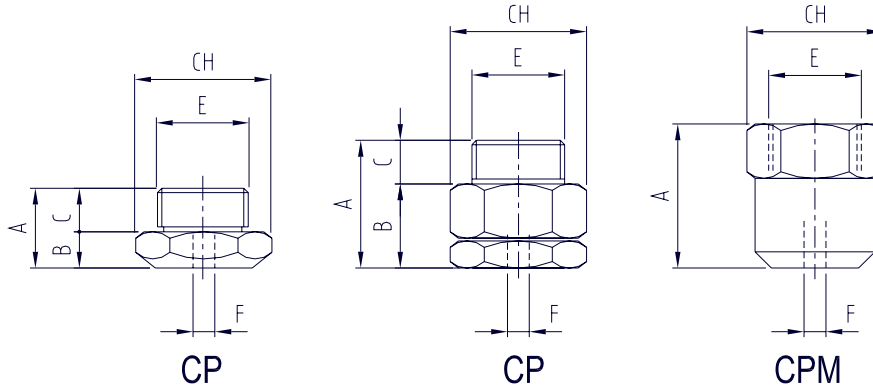

Type	CP	CP	CPM
Size at 45°- 60°- 90°	from 3 to 16	1 and 2	1 and 2
Size at 120°	from 2 to 16	-	-

Type dimensions at 45° - 60° - 90°

Size	Type	A mm	B mm	C mm	D mm	E Gas	F mm	CH mm
1	CP	25	16	9	-	3/8"	2.1 – 4.4	22
1	CPM	25	-	-	-	3/8"	2.1 – 4.4	22
2	CP	29	19	10	-	1/2"	5.3 – 6.3	27
2	CPM	29	-	-	-	1/2"	5.3 – 6.3	27
3	CP	22	12	10	-	1"	6.3 – 8	32
4	CP	27	15	12	-	1-1/4"	9 – 10.5	41
5	CP	30	16	14	-	1-1/2"	12.5	50
6	CP	35	19	16	-	2"	16	60
8	CP	44	26	18	-	2-1/2"	20	75
10	CP	52	30	22	-	2"	25	90
12	CP	60	36	24	-	3"	32	105
14	CP	65	39	26	-	3-1/2"	38	120
16	CP	90	50	40	-	4"	43	135

Type dimensions at 120°

Size	Type	A mm	B mm	C mm	D mm	E Gas	F mm	CH mm
1	CP	36	-	9	-	3/8"	4 – 5.3	22
2	CP	29	-	10	-	1/2"	6.3	27
3	CP	38	-	11	-	3/4"	8	32
4	CP	50	-	16	-	1"	10.5	41
5	CP	62	-	19	-	1-1/4"	12.5	50
6	CP	76	-	21	-	1-1/2"	16	50
8	CP	98	-	24	-	2"	20	60
10	CP	123	-	27	-	2-1/2"	25	75
12	CP	150	-	30	-	3"	32	85



FULL CONE JET SPRAY NOZZLE (CP – CPM)

Technical data

Spray nozzle		Flowrate (l/min.) at the pressure of (bar)										
Orifice (mm)	Size	0.25	0.5	1	2	3	4	5	6	7	10	20
0.6	0	-	-	0.20	0.30	0.35	0.40	0.45	0.50	0.55	0.65	0.90
0.8	0	-	-	0.35	0.50	0.60	0.70	0.80	0.85	0.90	1.00	1.50
1.2	0	-	-	0.75	1.00	1.20	1.40	1.60	1.80	2.00	2.50	3.50
1.5	0	-	-	1.00	1.50	2.00	2.20	2.50	2.70	3.00	3.50	5.00
1.9	0	-	-	1.50	2.00	2.50	3.00	3.20	3.50	3.70	4.50	6.50
2.2	0	-	-	2.00	2.50	3.10	3.60	4.00	4.50	5.00	6.00	8.00
2.1	1	-	-	2.50	3.50	4.00	4.50	5.00	5.50	6.00	7.00	10.0
2.5	1	-	2.0	3.00	4.00	5.00	6.00	6.50	7.00	7.50	9.00	13.0
2.8	1	-	2.5	3.50	5.00	6.50	7.50	8.00	9.00	9.50	11.5	16.0
3.3	1	-	3.5	4.50	6.50	8.00	9.00	10.0	11.0	12.0	14.0	20.0
4.0	1	-	5.0	7.50	10.0	12.5	14.5	16.0	17.50	19.0	22.5	32.0
4.4	1	4.5	6.5	9.00	12.5	15.5	18.0	20.0	22.0	24.0	28.0	40.0
5.3	1 – 2	5.5	8.0	11.5	16.0	20.0	23.0	25.0	27.0	30.0	35.0	50.0
6.3	2	7.0	10.0	14.0	20.0	25.0	28.0	32.0	35.0	37.0	45.0	63.0
6.9	2 - 3	11.0	16.0	22.5	31.5	39.0	45.0	50.0	55.0	59.0	70.0	100.0
8.0	3	14.0	20.0	28.0	40.0	49.0	56.0	63.0	69.0	75.0	90.0	125.0
9.0	4	18.0	25.0	35.0	50.0	61.0	70.0	80.0	88.0	95.0	113.0	160.0
10.5	4	22.5	31.5	45.0	63.0	78.0	90.0	100.0	110.0	120.0	140.0	200.0
12.5	5	35.0	50.0	70.0	100.0	123.0	140.0	160.0	175.0	190.0	230.0	320.0
16	6	56.0	50.0	112.0	160.0	194.0	225.0	250.0	274.0	296.0	354.0	500.0
20.0	8	90.0	125.0	180.0	250.0	310.0	360.0	400.0	438.0	474.0	566.0	800.0
25.0	10	140.0	200.0	280.0	400.0	490.0	560.0	630.0	690.0	750.0	900.0	1260.0
32.0	12	223.0	316.0	446.0	632.0	775.0	895.0	1000.0	1100.0	180.0	1410.0	2000.0
38.0	14	315.0	440.0	630.0	890.0	1090.0	1260.0	1400.0	1540.0	1660.0	2000.0	2800.0
43.0	16	400.0	570.0	800.0	1140.0	1400.0	1600.0	1800.0	1970.0	2120.0	2540.0	3600.0

HOLLOW CONE JET SPRAY NOZZLE (CC – CCX)

Dimensions

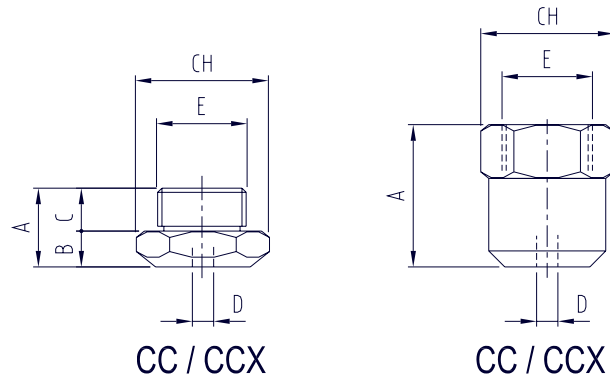

Dimensions

Size	Type	A mm	B Mm	C mm	D mm	E Gas	CH mm
0	CC	18	-	-	0.5	1/8"	17
	CCX				1.8		
1	CC	29	-	-	1	3/8"	22
	CCX				6		
2	CC	36	-	-	5	1/2"	27
	CCX				6		
3	CC	22	12	10	5.7	3/4"	32
	CCX				8.2		
4	CC	27	15	12	7	1"	41
	CCX				9.5		
5	CC	30	16	14	9	1-1/4"	50
	CCX				14.5		
6	CC	35	19	16	12	1-1/2"	60
	CCX				20		



HOLLOW CONE JET SPRAY NOZZLE (CC – CCX)

Technical data

Spray nozzle		Flowrate (l/min.) at the pressure of (bar)										
Orifice (mm)	Size	0.25	0.5	1	2	3	4	5	6	7	10	20
0.5	0	-	-	-	-	0.10	0.115	0.130	0.145	0.155	0.185	0.260
1.0	0	-	-	-	0.17	0.20	0.235	0.265	0.285	0.310	0.370	0.522
1.8	0	-	-	0.25	0.35	0.40	0.45	0.50	0.55	0.60	0.70	1.00
1.0	1	-	-	0.30	0.40	0.50	0.60	0.65	0.70	0.75	0.90	1.30
1.5	1	-	-	0.45	0.60	0.80	0.90	1.00	1.10	1.20	1.40	2.00
2.0	1	-	-	0.75	1.00	1.20	1.40	1.60	1.70	1.90	2.30	3.20
3.0	1	-	-	1.20	1.70	2.10	2.40	2.70	3.00	3.20	3.80	5.40
3.0 X	1	-	2.00	3.00	4.00	5.00	5.50	6.50	7.00	7.50	9.00	13.0
4.0	1	-	-	1.50	2.50	3.00	3.50	4.00	4.50	5.00	6.00	8.00
4.0 X	1	-	2.50	3.50	5.00	6.50	7.20	8.00	9.00	9.50	11.5	16.0
5.0 X	1	-	3.50	4.50	6.50	8.00	9.00	10.0	11.0	12.0	14.0	20.0
6.0 X	1	-	4.00	6.00	8.00	10.0	12.0	13.0	14.5	15.5	18.5	26.5
5.5	2	-	2.50	3.50	4.50	5.50	6.50	7.50	8.00	8.50	10.0	14.5
5.5 X	2	-	4.00	5.50	8.00	10.0	11.5	12.5	14.0	15.0	18.0	25.0
6.5	2	-	3.00	4.00	5.50	7.00	8.00	9.00	10.0	11.0	12.5	17.5
6.5 X	2	4.00	5.50	8.00	11.0	13.5	15.5	17.5	19.0	20.5	24.5	35.0
7.5 X	2	4.50	6.50	9.00	12.5	15.5	18.0	20.0	22.0	24.0	28.0	40.0
9.0 X	2	5.50	8.00	11.5	16.0	19.5	22.5	25.0	27.0	30.0	35.0	50.0
6.9	3	7.00	10.0	14.0	20.0	24.5	28.0	31.5	34.5	37.0	45.0	63.0
8.2	3	9.00	12.5	18.0	25.0	30.5	36.0	40.0	44.0	47.0	57.0	80.0
8.0	4	11.5	16.0	22.5	31.5	38.5	45.5	50.0	55.0	59.0	70.0	100.0
9.5	4	14.0	20.0	28.0	40.0	49.0	56.0	63.0	69.0	75.0	90.0	125.0
10	5	18.0	25.0	35.0	50.0	60.0	70.0	80.0	88.0	95.0	113.0	160.0
12.5	5	22.5	31.5	45.0	63.0	78.0	90.0	100.0	110.0	120.0	140.0	200.0
14.5	5	28.0	40.0	56.0	80.0	97.0	112.0	125.0	137.0	148.0	177.0	250.0
14.2	6	35.0	50.0	70.0	100.0	123.0	140.0	160.0	175.0	190.0	230.0	320.0
17.0	6	45.0	63.0	90.0	125.0	155.0	180.0	200.0	220.0	237.0	281.0	400.0
20.0	6	56.0	80.0	112.0	160.0	194.0	225.0	250.0	274.0	296.0	354.0	500.0

HOLLOW CONE JET SPRAY NOZZLE (CEa – CEB – CEc - CEr)

Dimensions

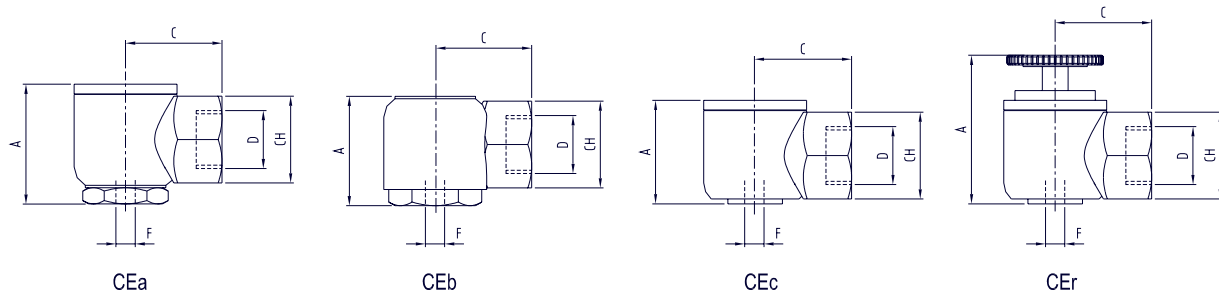

Dimensions

Size	Type	A mm	B mm	C mm	D gas	CH mm
1	CEa	27	1 ÷ 4	23	3/8"	22
2	CEa	38	5 ÷ 8	30	1/2"	27
3	CEa	48	9 ÷ 15	40	3/4"	36
4	CEa	60	15 ÷ 18	50	1"	46
5	CEa	90	20 ÷ 25	60	1-1/2"	60
6	CEa	120	25 ÷ 30	70	2"	80
7	CEa	150	35 ÷ 45	80	2-1/2"	100
1	CEb	25	1 ÷ 5	23	3/8"	22
4/90°	CEb	58	19 ÷ 25	58	1"	46
4/130°	CEb	58	26	58	1"	46
6	CEb	75	37	67	1-1/2"	60
8/90°	CEb	91	33 ÷ 40	85	2"	75
8/130°	CEb	91	45	85	2"	75
10	CEb	128	64	115	2-1/2"	90
1	CEc	23	5 / 7.5	23	3/8"	22
2	CEc	33	12	30	1/2"	27
3	CEc	45	19	40	3/4"	36
1	CEr	36	2 / 4	23	3/8"	22
2	CEr	45	6	30	1/2"	27
3	CEr	55	10	40	3/4"	36



HOLLOW CONE JET SPRAY NOZZLE (CEa – CEb – CEc - CEr)
Technical data

Spray nozzle			Flowrate (l/min.) at the pressure of (bar)										
Orifice (mm)	Type	Size	0.25	0.5	1	2	3	4	5	6	7	10	20
1.1 1.3	CEc CEa - CEb	1	-	-	0.45	0.63	0.78	0.90	1.00	1.10	1.18	1.41	2.00
1.7 2.0	CEc CEa – CEb - CEr	1	-	-	1.0	1.4	1.7	2.0	2.2	2.4	2.6	3.1	4.4
2.5 3.0	CEc CEa – CEb	1	-	1.1	1.5	2.2	2.6	3.0	3.4	3.7	4.0	4.8	6.8
3.5 4.0	CEc CEa – CEb	1	-	1.6	2.2	3.2	3.9	4.5	5.0	5.5	5.9	7.1	10.0
3.6	CEc	1	1.6	2.3	3.3	4.6	5.7	6.5	7.3	8.0	8.6	10.3	14.6
4.3	CEc	1	1.3	1.9	2.6	3.7	4.6	5.3	5.9	6.5	7.0	8.4	11.8
5.0	CEb	1	1.5	2.1	2.9	4.2	5.1	5.9	6.6	7.2	7.8	9.3	13.2
4.0	CEc	1	1.9	2.8	3.9	5.5	6.7	7.8	8.7	9.5	10.3	12.3	17.4
4.7 6.0	CEc CEc – CEr	1 2	2.5	3.3	4.9	7.0	8.5	9.8	11.0	12.0	13.0	15.6	22.0
3.6	CEc	2	1.8	2.5	3.5	5.0	6.1	7.1	7.9	8.7	9.4	11.2	15.8
4.2	CEc	2	2.6	3.7	5.3	7.5	9.2	10.6	11.8	13.0	14.0	16.8	23.5
8.0	CEa	2	3.3	4.7	6.6	9.4	11.5	13.2	14.8	16.2	17.5	20.9	29.6
4.0	CEc	2	2.8	4.0	5.6	8.0	9.8	11.3	12.6	13.8	14.9	17.8	25.2
5.0	CEc	2	3.7	5.2	7.4	10.5	12.8	14.8	16.5	18.1	19.5	23.4	33.0
5.7	CEc	3	6.3	9.0	13.0	18.0	22.0	25.0	28.0	31.0	33.0	40.0	56.0
7.0	CEc	2	6.0	8.5	12.0	17.0	20.8	24.0	26.8	29.4	31.8	38.0	53.6
7.3	CEc	3	9.0	13.0	18.0	26.0	32.0	37.0	41.0	45.0	49.0	58.0	82.0
9.0 10.0	CEa CEb	3 1	6.3	9.0	13.0	18.0	22.0	25.0	28.0	31.0	33.0	40.0	56.0
9.5 10.0	CEa CEb	3 1	9.0	13.0	18.0	26.0	32.0	37.0	41.0	45.0	49.0	58.0	82.0
12.0	CEa	3	9.0	13.0	18.0	26.0	32.0	37.0	41.0	45.0	49.0	58.0	82.0
8.6 15.0	CEc CEr	3 3	12.0	17.0	24.0	34.0	42.0	48.0	54.0	59.0	64.0	76.0	108.0
13.4 15.0	CEb CEa	4 4	21.0	30.0	42.0	60.0	73.0	85.0	95.0	104.0	112.0	135.0	190.0
14.2 18.0	CEb CEa	4 4	28.0	40.0	56.0	79.0	97.0	112.0	125.0	137.0	148.0	177.0	250.0
19.3 20.0	CEb CEa	6 5	42.	60.0	85.0	120.0	147.0	170.0	190.0	208.0	225.0	268.0	380.0
22.1 25.0	CEb CEa	6 5	56.0	72.0	112.0	158.0	194.0	224.0	250.0	274.0	296.0	354.0	500.0
24.7 25.0	CEb CEa	8 6	70.0	100.0	141.0	200.0	244.0	282.0	315.0	345.0	372.0	445.0	630.0
27.1 30.0	CEb CEa	8 6	85.0	120.0	170.0	240.0	294.0	340.0	380.0	415.0	450.0	536.0	760.0



HOLLOW CONE JET SPRAY NOZZLE (CEa – CEb – CEc - CEr)
Technical data

Spray nozzle			Flowrate (l/min.) at the pressure of (bar)										
Orifice (mm)	Type	Size	0.25	0.5	1	2	3	4	5	6	7	10	20
25.5	CEb	10	105.0	148.0	21.0	397.0	364.0	420.0	470.0	515.0	555.0	665.0	940.0
35.0	CEa	7											
33.0	CEb	10	141.0	200.0	282.0	400.0	490.0	563.0	630.0	690.0	745.0	890.0	1260
40.0	CEa	7											
38.0	CEb	10	175.0	247.0	350.0	493.0	605.0	700.0	780.0	855.0	923.0	1100	1560
45.0	CEa	7											
43.0	CEb	10	192.0	272.0	384.0	542.0	665.0	770.0	860.0	940.0	1015	1215	1720

HOLLOW CONE JET SPRAY NOZZLE (CN – CNm – CNr)

Dimensions

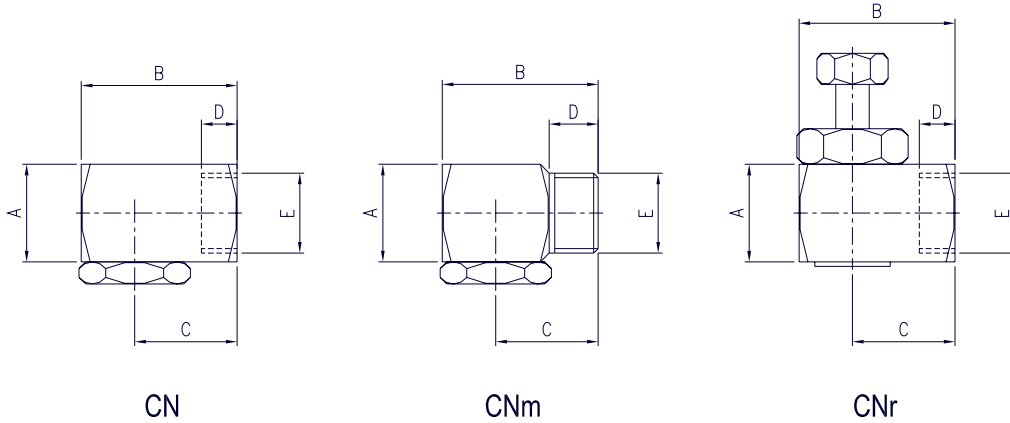

Type	CN	CMm	CNr
Size	from 1 to 8	1 and 2	from 1 to 3
Spray angle	60°- 80°- 120°- 160°	60° and 90°	60° and 90°

Dimensions

Size	Type	A mm	B mm	C mm	D mm	E mm
1	CN	20-22	35-38	29	10	3/8"
2	CN	25	35-40	35	10	1/2"
3	CN	35	50	33	10	3/4"
4	CN	45	65	40	12	1"
5	CN	60	80	55	15	1-1/4"
6	CN	70	95	62	17	1-1/2"
8	CN	80	115	72	18	2"
1	CNm	20	38	29	13	3/8"
2	CNm	24	40	30	13	1/2"
1	CNr	20	38	29	13	3/8"
2	CNr	25	40	35	10	1/2"
3	CNr	35	50	33	10	3/4"



HOLLOW CONE JET SPRAY NOZZLE (CN – CNm – CNr)
Technical data

Spray nozzle			Flowrate (l/min.) at the pressure of (bar)										
Orifice (mm)	Type	Size	0.25	0.5	1	2	3	4	5	6	7	10	20
1.1 1.3	CNm CN	1	-	-	0.45	0.63	0.78	0.90	1.00	1.10	1.18	1.41	2.00
2.0	CN – CNr	1	-	-	1.0	1.4	1.7	2.0	2.2	2.4	2.6	3.1	4.4
2.5 3.0	CNm CN	1	-	1.1	1.5	2.2	2.6	3.0	3.4	3.7	4.0	4.8	6.8
3.5 4.0	CNm CN – CNr	1	-	1.6	2.2	3.2	3.9	4.5	5.0	5.5	5.9	7.1	10.0
3.6	CNm	1	1.6	2.3	3.3	4.6	5.7	6.5	7.3	8.0	8.6	10.3	14.6
4.3	CNm	1	1.3	1.9	2.6	3.7	4.6	5.3	5.9	6.5	7.0	8.4	11.8
5.0	CN	1	1.5	2.1	2.9	4.2	5.1	5.9	6.6	7.2	7.8	9.3	13.2
4.0	CNm	1	1.9	2.8	3.9	5.5	6.7	7.8	8.7	9.5	10.3	12.3	17.4
4.7 6.0	CNm CNr – CNm	1 2	2.5	3.3	4.9	7.0	8.5	9.8	11.0	12.0	13.0	15.6	22.0
3.6	CNm	2	1.8	2.5	3.5	5.0	6.1	7.1	7.9	8.7	9.4	11.2	15.8
4.2	CNm	2	2.6	3.7	5.3	7.5	9.2	10.6	11.8	13.0	14.0	16.8	23.5
8.0	CN	2	3.3	4.7	6.6	9.4	11.5	13.2	14.8	16.2	17.5	20.9	29.6
4.0	CNm	2	2.8	4.0	5.6	8.0	9.8	11.3	12.6	13.8	14.9	17.8	25.2
5.0	CNm	2	3.7	5.2	7.4	10.5	12.8	14.8	16.5	18.1	19.5	23.4	33.0
5.7	CNm	3	6.3	9.0	13.0	18.0	22.0	25.0	28.0	31.0	33.0	40.0	56.0
7.0	CNm	2	6.0	8.5	12.0	17.0	20.8	24.0	26.8	29.4	31.8	38.0	53.6
7.3	CNm	3	9.0	13.0	18.0	26.0	32.0	37.0	41.0	45.0	49.0	58.0	82.0
9.0 10.0	CN CN	3 1	6.3	9.0	13.0	18.0	22.0	25.0	28.0	31.0	33.0	40.0	56.0
9.5 10.0	CN CNm	3 1	9.0	13.0	18.0	26.0	32.0	37.0	41.0	45.0	49.0	58.0	82.0
12.0	CN	3	9.0	13.0	18.0	26.0	32.0	37.0	41.0	45.0	49.0	58.0	82.0
8.6 15.0	CNm CNr	3 3	12.0	17.0	24.0	34.0	42.0	48.0	54.0	59.0	64.0	76.0	108.0
13.4 15.0	CN CN	4 4	21.0	30.0	42.0	60.0	73.0	85.0	95.0	104.0	112.0	135.0	190.0
14.2 18.0	CN CN	4 4	28.0	40.0	56.0	79.0	97.0	112.0	125.0	137.0	148.0	177.0	250.0
19.3 20.0	CN CN	6 5	42.	60.0	85.0	120.0	147.0	170.0	190.0	208.0	225.0	268.0	380.0
22.1 25.0	CN CN	6 5	56.0	72.0	112.0	158.0	194.0	224.0	250.0	274.0	296.0	354.0	500.0
24.7 25.0	CN CN	8 6	70.0	100.0	141.0	200.0	244.0	282.0	315.0	345.0	372.0	445.0	630.0
27.1 30.0	CN CN	8 6	85.0	120.0	170.0	240.0	294.0	340.0	380.0	415.0	450.0	536.0	760.0



HOLLOW CONE JET SPRAY NOZZLE (CN – CNm – CNr)
Technical data

Spray nozzle			Flowrate (l/min.) at the pressure of (bar)										
Orifice (mm)	Type	Size	0.25	0.5	1	2	3	4	5	6	7	10	20
25.5	CN	10	105.0	148.0	21.0	397.0	364.0	420.0	470.0	515.0	555.0	665.0	940.0
35.0	CN	7											
33.0	CN	10	141.0	200.0	282.0	400.0	490.0	563.0	630.0	690.0	745.0	890.0	1260
40.0	CN	7											
38.0	CN	10	175.0	247.0	350.0	493.0	605.0	700.0	780.0	855.0	923.0	1100	1560
45.0	CN	7											
43.0	CN	10	192.0	272.0	384.0	542.0	665.0	770.0	860.0	940.0	1015	1215	1720