

Low Pressure Carbon Dioxide Fire Suppression System

Features

- FM Approved
- Wide range of CO₂ storage units available (3 3/4 ton (3402 kg) to 46 ton (41731 kg) capacity)
- Hydraulic program for piping design and nozzle sizing
- CO₂ storage units are saddle mounted
- Low profile design
- NEMA 4 power control box

Applications

The following are typical hazards protected by carbon dioxide systems:

- Printing presses
- Transformer vaults/electrical cabinets
- Open pits
- Dip tanks
- Rolling mills
- Ovens
- Coating machines
- Process equipment
- Exhaust and fume handling systems
- Flammable gas or liquid storage areas
- Generators
- Inerting applications

Description

The ANSUL® Commercial Low Pressure CO₂ Fire Suppression System is designed to meet the requirements of NFPA 12, "Standard on Carbon Dioxide Extinguishing Systems." The system consists of a low pressure storage unit, selector valves, manual and automatic controls, distribution nozzles, alarms, indicators, and supervisory devices as required to maintain a supply of carbon dioxide in a discharge-ready state, and to provide effective distribution of agent on demand.

The low pressure system consists of liquid CO₂ stored in an ASME coded pressure vessel which is equipped with a refrigeration system. The pressure within the vessel is kept near 300 psi (20.7 bar) by maintaining the internal temperature at approximately 0 °F (-18 °C). A manually operated tank shut-off valve, which is used to isolate the supply from the distribution network, is fitted to the storage unit. Low pressure storage units are available in sizes from 3 3/4 ton (3402 kg) up to 46 ton (41731 kg) capacity.



002455

Distribution of CO₂ is accomplished through a selector valve or a hand-hose line arrangement. A selector valve arrangement is commonly used when multiple hazards are protected from a common supply manifold that is located in close proximity to the storage unit. The master and selector valve arrangement is typically used to protect several hazards from the same supply manifold where the selector valve is located close to the hazard and at a significant distance from the storage unit. Hand-hose lines can either be supplied from a separate low pressure storage unit or connected to the same storage unit that supplies a fixed pipe system. In all cases, the hand hose line has its own operating discharge valve.

The carbon dioxide is distributed to the protected space through a piping network and discharge nozzles that are sized in accordance with the ANSUL Low Pressure CO₂ flow calculation software. The type of nozzles used depends upon the specific flow and distribution requirements of each application.

Valve control is accomplished through electro-pneumatic or manual means. Each selector valve assembly consists of a ball or butterfly valve, a spring return pneumatic valve operator and an electrically operated solenoid valve. Selector valves with spring return actuators, solenoid valves, and pneumatic delay timers are available. A listed and approved releasing control panel is used to provide automatic detection and control. CO₂ vapor from the storage container is regulated to approximately 100 psi (6.9 bar) and piped to the inlet of the electrically operated solenoid valve. Upon receipt of an electrical actuation signal from the releasing panel, the solenoid valve operates, opening the selector valve and allowing the CO₂ extinguishing agent to flow into the protected area. When the discharge timing cycle is complete, the electrical actuation signal is removed. Deactivation of the actuation signal returns the selector valve to its stand-by position.

Component Description

Low Pressure CO₂ Storage Unit: The low pressure storage unit is built to the ASME code for unfired pressure vessels. The storage unit is available in sizes from 3 3/4 ton (3402 kg) to 46 ton (41731 kg). The pressure vessel has piping for filling, for supplying CO₂ vapor to the system controls, and a large outlet for discharging CO₂ into the protected hazard. The pressure vessel is covered with 4 in. (102 mm) of polyurethane insulation. The insulation is covered with an aluminum vapor barrier. The pressure vessel is provided in a saddle mount configuration.

The pressure vessel is equipped with a safety relief valve(s) in accordance with ASME requirements. In addition to the safety relief valve required by ASME, the pressure vessel is also supplied with an auxiliary relief device known as a "bleeder" valve.

In the upper part of the pressure vessel, refrigerant evaporator coils serve to cool the stored CO₂. A refrigeration unit supplies low pressure refrigerant to the evaporator coils inside the pressure vessel. The refrigerant extracts heat from the CO₂ vapor which surrounds the coils. The refrigeration compressor cycle is controlled by a pressure switch which monitors the pressure of the CO₂ within the vessel. Pressure of the CO₂ inside the tank is lowered to 295 psi (20.3 bar). The refrigeration compressor turns on when the CO₂ pressure reaches 305 psi (21.0 bar). When the vapor space temperature is cooled to about 0 °F (-18 °C), the CO₂ pressure switch opens to start the refrigerant pump-down cycle and turn off the compressor.

CO₂ Agent: Carbon dioxide is an effective fire suppressing agent that can be used on many types of fires. It is effective for surface fires, such as flammable liquids and most solid combustible materials. It expands at a ratio of 450 to 1 by volume. For fire suppression purposes, the discharge is designed to raise the carbon dioxide concentration in the hazard. This displaces the air, which contains oxygen that supports combustion, and results in fire suppression. Other attributes are its high degree of effectiveness, its excellent thermal stability, and its freedom from deterioration. It is electrically non-conductive, and leaves no residue to clean up after discharge.

Nozzles: Nozzles are designed to direct the discharge of CO₂ in the hazard area. The system design specifies the orifice size to be used for proper flow rate and distribution pattern. The nozzle selection depends on the hazard and location to be protected. Standard nozzles are painted red or are natural brass, depending on the type. All are corrosion resistant.

Distribution Valves: Valves which control the discharge of CO₂ into the protected space(s) can be arranged in one of two configurations: master and selector, or selector. Operation of the valve(s) is done pneumatically, electro-pneumatically, or manually.

MASTER AND SELECTOR: There are two discharge valves in the flow path between the low pressure storage unit outlet and the discharge nozzles. Starting from the storage unit, the first valve is the "master" valve. The valve downstream of the master valve is the "selector" valve. In most master and selector valve systems, one master valve will serve several selector valves. The advantage to this type of configuration is that it permits installing a single pipe from the storage unit to several distant hazards. The savings in installation cost by installing a single pipe rather than multiple individual pipes may more than offset the cost of the master valve and controls.

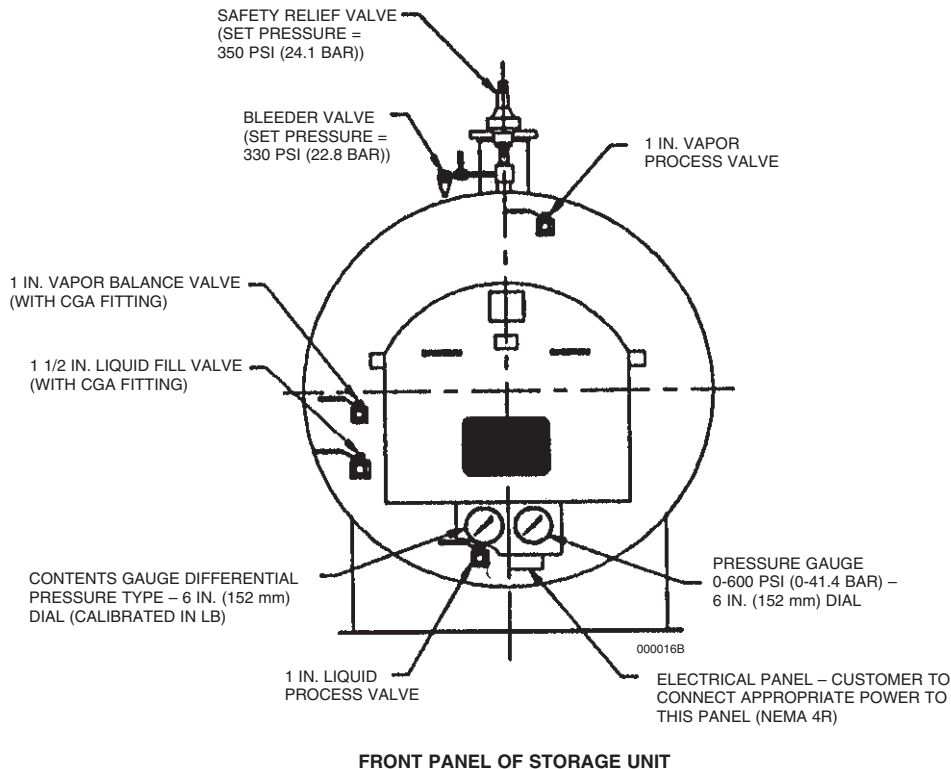

Component Description (Continued)

SELECTOR: There is a single selector valve in the flow path between the low pressure storage unit outlet and the discharge nozzles. This configuration is typically used to protect multiple hazards which are 1) close to the low pressure storage unit and 2) widely separated from other protected hazards. Cost of the equipment is less than that of a master and selector arrangement, but installation may be greater if several large diameter pipe runs must be installed from the low pressure storage unit to the hazards.

Hose Reels: In addition to the fixed pipe systems, hose reels can be supplied by a low pressure storage unit. Hose reels consist of a corrosion resistant painted reel. Several different lengths of 1 in. (25 mm) hose are available.

Available Options

- Dual relief valves with diverter valve
- NEMA 4X power control box
- Liquid level gauge switches (one or two)
- Dual refrigeration systems
- 200 VAC, 1 phase, 50 Hz refrigeration unit (3 3/4 ton (3402 kg) through 10 ton (9072 kg) only)
- 200/220 VAC, 3 phase, 50 Hz refrigeration unit (all sizes)
- 460 VAC, 3 phase, 60 Hz refrigeration unit (all sizes)
- 208/230 VAC, 1 phase, 60 Hz refrigeration unit (3 3/4 ton (3402 kg) through 10 ton (9072 kg), and 14 ton (12701 kg) only)
- 208/230 VAC, 3 phase, 60 Hz refrigeration unit (all sizes)

Approvals

ANSUL Low Pressure Carbon Dioxide Systems are designed to meet the requirements of NFPA 12 "Standard on Carbon Dioxide Extinguishing Systems." They are Factory Mutual (FM) Approved.

Ordering Information

Order all system components through your Authorized ANSUL Distributor who carries the ANSUL Low Pressure CO₂ System product line.

Nominal Tank Capacity (Tons)	Part No.	A Length		B Width		C Height		D Lift Lugs		E Dip Tube		Empty Weight		Weight of CO ₂	
		ft-in.	(m)	ft-in.	(m)	ft-in.	(m)	ft-in.	(m)	in.	(mm)	lb	(kg)	lb	(kg)
3.75	425950	11-10	3.6	5-10	1.8	8-6	2.6	2-8	1	4	102	7500	3402	7500	3402
3.75*	440443	11-10	3.6	5-10	1.8	8-6	2.6	2-8	1	4	102	7500	3402	7500	3402
6	441609	15-10	4.8	5-10	1.8	8-6	2.6	5-0	1.6	4	102	9000	4082	12000	5443
6	425899	15-10	4.8	5-10	1.8	8-6	2.6	5-0	1.6	6	152	9000	4082	12000	5443
6*	440447	15-10	4.8	5-10	1.8	8-6	2.6	5-0	1.6	6	152	9000	4082	12000	5443
6*	440461	15-10	4.8	5-10	1.8	8-6	2.6	5-0	1.6	6	152	9000	4082	12000	5443
8	425928	19-2	5.8	5-10	1.8	8-6	2.6	8-6	2.6	6	152	10200	4627	16000	7257
8*	440419	19-2	5.8	5-10	1.8	8-6	2.6	8-6	2.6	6	152	10200	4627	16000	7257
10	437372	23-4	7.1	5-10	1.8	8-6	2.6	12-3	3.7	8	203	11500	5216	20000	9072
10*	440420	23-4	7.1	5-10	1.8	8-6	2.6	12-3	3.7	8	203	11500	5216	20000	9072
12	437369	26-5	8.1	5-10	1.8	8-6	2.6	15-4	4.7	8	203	12650	5738	24000	10886
12*	440421	26-5	8.1	6-7	2.0	8-6	2.6	15-4	4.7	8	203	12650	5738	24000	10886
14	440307	20-7	6.3	7-4	2.2	10-3	3.1	7-4	2.2	8	203	14000	6350	28000	12701
14*	440422	20-7	6.3	7-4	2.2	10-3	3.1	7-4	2.2	8	203	14000	6350	28000	12701
14	441759	20-7	6.3	7-4	2.2	10-3	3.1	7-4	2.2	8	203	14000	6350	28000	12701
14*	441760	20-7	6.3	7-4	2.2	10-3	3.1	7-4	2.2	8	203	14000	6350	28000	12701
18	440308	25-1	6.9	7-4	2.2	10-3	3.1	10-0	3.3	8	203	16800	7621	36000	16329
18*	440423	25-1	6.9	7-4	2.2	10-3	3.1	10-0	3.3	8	203	16800	7621	36000	16329
22	440551	29-1	8.7	7-4	2.2	10-3	3.1	14-0	4.3	8	203	20500	9299	44000	19958
22*	440309	29-1	8.7	7-4	2.2	10-3	3.1	14-0	4.3	8	203	20500	9299	44000	19958
30	440554	37-1	11.1	7-4	2.2	10-3	3.1	22-0	6.7	8	203	26500	12020	60000	27216
30*	440312	37-1	11.1	7-4	2.2	10-3	3.1	22-0	6.7	8	203	26500	12020	60000	27216
38	440557	44-7	13.6	7-4	2.2	10-3	3.1	30-0	6.8	8	203	33000	14970	76000	34473
38*	440560	44-7	13.6	7-4	2.2	10-3	3.1	30-0	6.8	8	203	33000	14970	76000	34473
46	440377	53-1	16.0	7-4	2.2	10-3	3.1	38-0	7.7	8	203	37500	17010	92000	41731
46*	440565	53-1	16.2	7-4	2.2	10-3	3.1	38-0	11.6	8	203	37500	17010	92000	41731

*Dual Refrigeration System Models

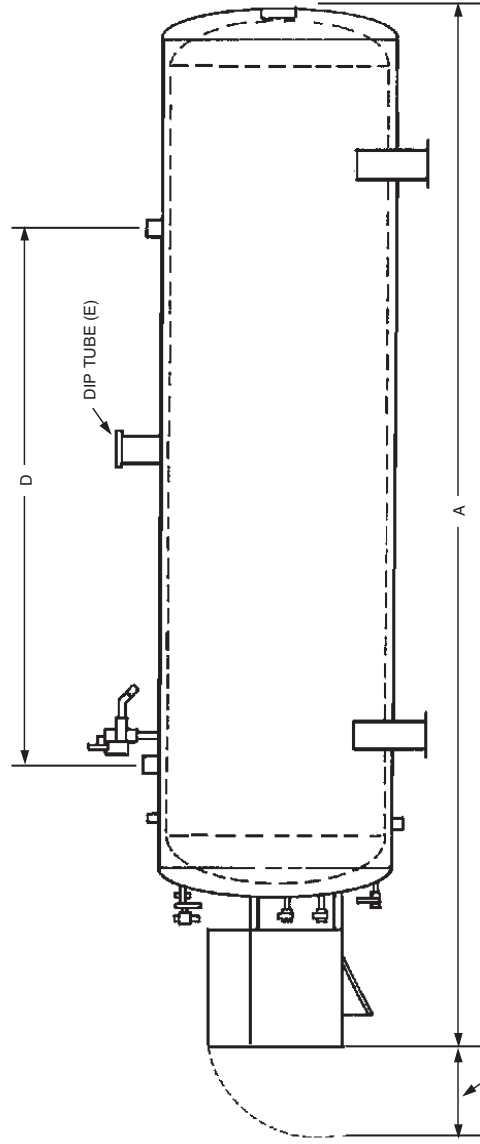
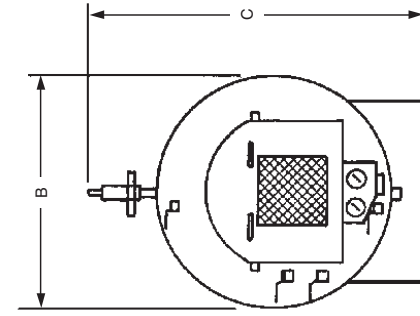

ALLOW 4 FT. (1.2 m) CLEARANCE FOR TILT DOWN CONTROL CABINET